

# State of Nebraska - INVITATION TO BID CONTRACT

<b>Date</b>	9/30/21	<b>Page</b>	1 of 3
<b>Solicitation Number</b>	6581 OF		
<b>Opening Date and Time</b>	10/29/21	2:00 pm	
<b>Buyer</b>	ROBERT TAYLOR (AS)		

**DESTINATION OF GOODS**  
 DEPARTMENT OF TRANSPORTATION  
 5001 S 14TH ST  
 PO BOX 94759  
 LINCOLN NE 68509-4759

Per Nebraska's Transparency in Government Procurement Act, DAS is required to collect statistical information regarding the number of contracts awarded to Nebraska contractors. This information is for statistical purposes only and will not be considered for contract award purposes.

\_\_\_\_ NEBRASKA CONTRACTOR AFFIDAVIT: Bidder hereby attests that bidder is a Nebraska Contractor. " Nebraska Contractor" shall mean any bidder who has maintained a bona fide place of business and at least one employee within this state for at least the six (6) months immediately preceding the posting date of this ITB.

\_\_\_\_ I hereby certify that I am a Resident disabled veteran or business located in a designated enterprise zone in accordance with Neb. Rev. Stat. §73-107 and wish to have preference, if applicable, considered in the award of this contract.

Contract to supply and deliver TANDEM AXLE CHASSIS, MINIMUM 60,000 GVWR WITH RDS DUMP BODY & TOW PLOW, HYDRAULICS, PLOW HITCH to the State of Nebraska as per the attached specifications for a two (2) year period from date of award. The contract may be renewed for three (3) additional one (1) year periods when mutually agreeable to the vendor and the State of Nebraska.

(09/07/21 ml)

## INVITATION

Line	Description	Quantity	Unit of Measure	Unit Price	Extended Price
1	60000 GVWR TANDEM AXIL W14' RDS DUMP BODY & TOP PLOW	10.0000	EA	_____	_____
2	FULLER 10 SPEED TRANSMISSION	10.0000	EA	_____	_____
3	FULLER 13 SPEED TRANSMISSION	10.0000	EA	_____	_____
4	FULLER EATON ULTRASHIFT 10 SPEED TRANSMISSION	10.0000	EA	_____	_____

### BIDDER MUST COMPLETE THE FOLLOWING

DISCOUNT PAYMENT TERMS: \_\_\_\_\_ % \_\_\_\_\_ DAYS

By signing this Invitation to Bid form, the bidder guarantees compliance with the provisions stated in this Invitation to Bid, agrees to the terms and conditions unless otherwise agreed to and certifies that bidder maintains a drug free work place environment. Vendor will furnish the items requested within \_\_\_\_\_ days after receipt of order. Failure to enter Delivery Date may cause quotation to be REJECTED.

**Sign**

**Here** \_\_\_\_\_  
 (Authorized Signature Mandatory – Form must be signed manually in ink or by DocuSign)

Enter Contact Information Below

**VENDOR#** \_\_\_\_\_  
**VENDOR:** \_\_\_\_\_  
**Address:** \_\_\_\_\_  
 \_\_\_\_\_  
 \_\_\_\_\_

**Contact** \_\_\_\_\_  
**Telephone** \_\_\_\_\_  
**Email** \_\_\_\_\_

# State of Nebraska - INVITATION TO BID CONTRACT

<b>Date</b>	9/30/21	<b>Page</b>	2 of 3
<b>Solicitation Number</b>	6581 OF		
<b>Opening Date and Time</b>	10/29/21	2:00 pm	
<b>Buyer</b>	ROBERT TAYLOR (AS)		

**DESTINATION OF GOODS**  
DEPARTMENT OF TRANSPORTATION  
5001 S 14TH ST  
PO BOX 94759  
LINCOLN NE 68509-4759

## INVITATION

Line	Description	Quantity	Unit of Measure	Unit Price	Extended Price
5	FULLER EATON ULTRASHIFT 13 SPEED TRANSMISSION	10.0000	EA	_____	_____
6	FULLER EATON ULTRASHIFT 18 SPEED TRANSMISSION	10.0000	EA	_____	_____
7	V-PLOW WITH QUICK ATTACH HITCH	10.0000	EA	_____	_____
8	V-PLOW QUICK ATTACH HITCH WITHOUT V-PLOW	10.0000	EA	_____	_____
9	FRONT MOUNT PATROL WING	10.0000	EA	_____	_____
10	RIGHT HAND BENCHING WING	10.0000	EA	_____	_____
11	RIGHT HAND HIGH BENCHING WING	10.0000	EA	_____	_____
12	RIGHT HAND SEVED DUTY HIGH BENCHING WING	10.0000	EA	_____	_____
13	PRE WET SYSTEM	10.0000	EA	_____	_____
14	RIGHT HAND MID MOUNT WING	10.0000	EA	_____	_____
15	LEFT HAND MID MOUNT WING	10.0000	EA	_____	_____
16	3 JOYSTICK CONTROL IN LIEU OF SINGLE JOYSTICK CONTROL	10.0000	EA	_____	_____
17	ADD TOW PLOW	10.0000	EA	_____	_____
18	CHASSIS ONLY NO RDS BODY OR TOW PLOW	5.0000	EA	_____	_____
19	CHASSIS HYDRAULICS TO RUN TOW PLOW	5.0000	EA	_____	_____
20	ADD BI-DIRECTIONAL TOW PLOW	5.0000	EA	_____	_____
21	PLOW BALANCE VALVE	15.0000	EA	_____	_____
22	TRANSMISSION REPAIR MANUAL FOR MANUAL TRANSMISSION	15.0000	EA	_____	_____
23	TRANSMISSION REPAIR MANUAL	15.0000	EA	_____	_____

# State of Nebraska - INVITATION TO BID CONTRACT

<b>Date</b>	9/30/21	<b>Page</b>	3 of 3
<b>Solicitation Number</b>	6581 OF		
<b>Opening Date and Time</b>	10/29/21	2:00 pm	
<b>Buyer</b>	ROBERT TAYLOR (AS)		

**DESTINATION OF GOODS**  
 DEPARTMENT OF TRANSPORTATION  
 5001 S 14TH ST  
 PO BOX 94759  
 LINCOLN NE 68509-4759

## INVITATION

Line	Description	Quantity	Unit of Measure	Unit Price	Extended Price
	FOR AUTOMATIC TRANSMISSION				
24	<b>P.C. SOFTWARE WITH DATA LINK CONNECTION</b>	<b>15.0000</b>	<b>EA</b>	_____	_____
	OPTIONS:				
25	<b>SINGLE AXLE CAB</b>	<b>15.0000</b>	<b>EA</b>	_____	_____
26	<b>CHASSIS ONLY</b>	<b>15.0000</b>	<b>EA</b>	_____	_____

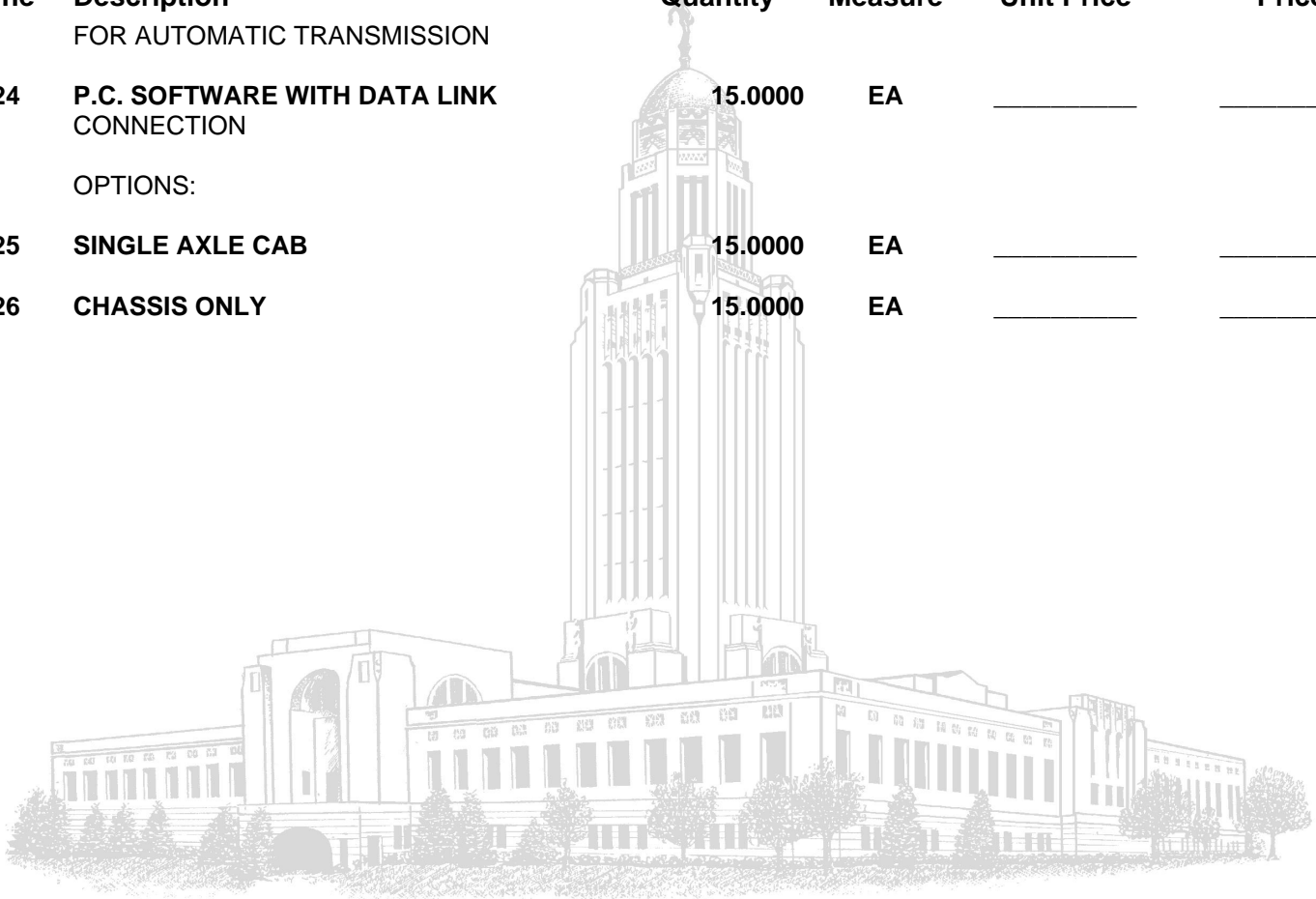

# INVITATION TO BID

## Number 6581 OF

The State of Nebraska (State), Department of Administrative Services (DAS), Materiel Division, State Purchasing Bureau (SPB), is issuing this solicitation for a commodity contract, ITB Number 6581 OF for the purpose of selecting a qualified Vendor to provide **TANDEM AXLE CHASSIS, MINIMUM 60,000 GVWR WITH RDS DUMP BODY & TOW PLOW, HYDRAULICS, PLOW HITCH**. A more detailed description can be found in Section V & VI. The resulting contract may not be an exclusive contract as the State reserves the right to contract for the same or similar goods from other sources now or in the future.

The term of the contract will be two (2) years commencing upon execution of the contract by the State and the Vendor notice to proceed After award of bid. The Contract includes the option to renew for three (3) additional one year (1) periods upon mutual agreement of the Parties. The State reserves the right to extend the period of this contract beyond the termination date when mutually agreeable to the Parties.

### INFORMATION PERTINENT TO THIS SOLICITATION CAN BE FOUND ON THE INTERNET AT:

<https://das.nebraska.gov/materiel/sites/purchasing.html>

**IMPORTANT NOTICE:** Pursuant to Neb. Rev. Stat. § 84-602.02, State contracts in effect as of January 1, 2014, and contracts entered into thereafter, must be posted to a public website. The resulting contract, the solicitation, and the successful Vendor's bid or response will be posted to a public website managed by DAS, which can be found at:

<https://statecontracts.nebraska.gov>

In addition and in furtherance of the State's public records statute (Neb. Rev. Stat. § 84-712 et seq.) all bids or responses received regarding this solicitation will be posted to the SPB website.

These postings will include the entire bid or response. Vendor must request that proprietary information be excluded from the posting. The Vendor must identify the proprietary information, mark the proprietary information according to state law, and submit the proprietary information in a separate container or envelope marked conspicuously using an indelible method with the words "PROPRIETARY INFORMATION". The Vendor must submit a **detailed written document showing** that the release of the proprietary information would give a business advantage to named business competitor(s) and explain how the named business competitor(s) will gain an actual business advantage by disclosure of information. The mere assertion that information is proprietary or that a speculative business advantage might be gained is not sufficient. (See Attorney General Opinion No. 92068, April 27, 1992) **THE VENDOR MAY NOT ASSERT THAT THE ENTIRE BID OR RESPONSE IS PROPRIETARY. COST WILL NOT BE CONSIDERED PROPRIETARY AND IS A PUBLIC RECORD IN THE STATE OF NEBRASKA.** The State will then determine, in its discretion, if the interests served by nondisclosure outweighs any public purpose served by disclosure. (See Neb. Rev. Stat. § 84-712.05(3)) The Vendor will be notified of the agency's decision. Absent a State determination that information is proprietary, the State will consider all information a public record subject to release regardless of any assertion that the information is proprietary.

If the agency determines it is required to release proprietary information, the Vendor will be informed. It will be the Vendor's responsibility to defend the Vendor's asserted interest in non-disclosure.

To facilitate such public postings, with the exception of proprietary information, the State of Nebraska reserves a royalty-free, nonexclusive, and irrevocable right to copy, reproduce, publish, post to a website, or otherwise use any contract, bid, or response to this solicitation for any purpose, and to authorize others to use the documents. Any individual or entity awarded a contract, or who submits a bid or response to this solicitation, specifically waives any copyright or other protection the contract, bid, or response to the solicitation may have; and, acknowledges that they have the ability and authority to enter into such waiver. This reservation and waiver are a prerequisite for submitting a bid or response to this solicitation, and award of a contract. Failure to agree to the reservation and waiver will result in the bid or response to the solicitation being found non-responsive and rejected.

**Any entity awarded a contract or submitting a bid or response to the solicitation agrees not to sue, file a claim, or make a demand of any kind, and will indemnify and hold harmless the State and its employees, volunteers, agents, and its elected and appointed officials from and against any and all claims, liens, demands, damages, liability, actions, causes of action, losses, judgments, costs, and expenses of every nature, including investigation costs and expenses, settlement costs, and attorney fees and expenses, sustained or asserted against the State, arising out of, resulting from, or attributable to the posting of the contract or the bids and responses to the solicitation, awards, and other documents.**

# TABLE OF CONTENTS

INVITATION TO BID.....		i
TABLE OF CONTENTS.....		ii
GLOSSARY OF TERMS.....		vi
ACRONYM LIST.....		x
<b>I. PROCUREMENT PROCEDURE.....</b>		<b>1</b>
A. GENERAL INFORMATION.....		1
B. PROCURING OFFICE AND COMMUNICATION WITH STATE STAFF AND EVALUATORS.....		1
C. SCHEDULE OF EVENTS.....		2
D. QUESTIONS AND ANSWERS.....		3
E. SECRETARY OF STATE/TAX COMMISSIONER REGISTRATION REQUIREMENTS (Statutory).....		3
F. ETHICS IN PUBLIC CONTRACTING.....		3
G. DEVIATIONS FROM THE INVITATION TO BID.....		3
H. SUBMISSION OF BIDS.....		4
I. BID PREPARATION COSTS.....		4
J. FAILURE TO COMPLY WITH INVITATION TO BID.....		4
K. BID CORRECTIONS.....		4
L. LATE BIDS.....		4
M. BID OPENING.....		4
N. INVITATION TO BID/BID REQUIREMENTS.....		5
O. EVALUATION OF BIDS.....		5
P. BEST AND FINAL OFFER.....	Error! Bookmark not defined.	
Q. REFERENCE AND CREDIT CHECKS.....		5
R. AWARD.....		6
S. SPECIFICATIONS.....		6
T. ALTERNATE/EQUIVALENT BIDS.....		6
U. LUMP SUM OR "ALL OR NONE" BIDS.....		6
V. EMAIL SUBMISSIONS.....		6
W. BID TABULATIONS.....		6
X. REJECTION OF BIDS.....		6
Y. RESIDENT BIDDER.....		6
<b>II. TERMS AND CONDITIONS.....</b>		<b>8</b>
A. GENERAL.....		8
B. NOTIFICATION.....		9
C. NOTICE (POC).....		9
D. GOVERNING LAW (Statutory).....		9
E. AMENDMENT.....		9
F. CHANGE ORDERS OR SUBSTITUTIONS.....		9
G. VENDOR PERFORMANCE REPORT(S).....		10
H. NOTICE OF POTENTIAL VENDOR BREACH.....		10
I. BREACH.....		10
J. NON-WAIVER OF BREACH.....		11
K. SEVERABILITY.....		11
L. INDEMNIFICATION.....		11
M. ATTORNEY'S FEES.....		12
N. ASSIGNMENT, SALE, OR MERGER.....		12
O. CONTRACTING WITH OTHER POLITICAL SUB-DIVISIONS OF THE STATE OR ANOTHER STATE.....		12
P. FORCE MAJEURE.....		13
Q. CONFIDENTIALITY.....		13
R. EARLY TERMINATION.....		13
S. CONTRACT CLOSEOUT.....		14
<b>III. VENDOR DUTIES.....</b>		<b>15</b>
A. INDEPENDENT VENDOR / OBLIGATIONS.....		15
B. EMPLOYEE WORK ELIGIBILITY STATUS.....		15
C. COMPLIANCE WITH CIVIL RIGHTS LAWS AND EQUAL OPPORTUNITY EMPLOYMENT / NONDISCRIMINATION (Statutory).....		16
D. COOPERATION WITH OTHER VENDORS.....		16

E.	DISCOUNTS.....	16
F.	PRICES.....	16
G.	COST CLARIFICATION.....	17
H.	PERMITS, REGULATIONS, LAWS.....	17
I.	NOTICE OF POTENTIAL VENDOR BREACH.....	17
J.	ANTITRUST.....	17
K.	CONFLICT OF INTEREST.....	17
L.	ADVERTISING.....	18
M.	DISASTER RECOVERY/BACK UP PLAN.....	18
N.	DRUG POLICY.....	18
O.	WARRANTY.....	18
<b>IV.</b>	<b>PAYMENT.....</b>	<b>19</b>
A.	PROHIBITION AGAINST ADVANCE PAYMENT (Statutory).....	19
B.	TAXES (Statutory).....	19
C.	INVOICES.....	19
D.	INSPECTION AND APPROVAL.....	19
E.	PAYMENT (Statutory).....	19
F.	LATE PAYMENT (Statutory).....	19
G.	SUBJECT TO FUNDING / FUNDING OUT CLAUSE FOR LOSS OF APPROPRIATIONS (Statutory).....	19
H.	RIGHT TO AUDIT (First Paragraph is Statutory).....	19
<b>V.</b>	<b>SCOPE OF WORK.....</b>	<b>21</b>
A.	SCOPE.....	21
<b>VI.</b>	<b>TECHNICAL SPECIFICATIONS.....</b>	<b>22</b>
A.	VENDOR INSTRUCTIONS.....	22
B.	NON-COMPLIANCE STATEMENT.....	22
C.	BASIC SPECIFICATIONS.....	22
D.	TRANSMISSION.....	23
E.	AXLES AND SPRINGS & SHOCK ABSORBERS.....	23
F.	STEERING.....	24
G.	BRAKES.....	24
H.	ENGINE.....	25
I.	FILTERS.....	26
J.	COOLING.....	26
K.	FUEL TANK.....	26
L.	WHEELS.....	27
M.	TIRES.....	27
N.	CAB.....	27
O.	COLOR.....	28
P.	MIRRORS.....	28
Q.	LIGHTS.....	28
R.	CONTROLS & INSTRUMENTS.....	29
S.	WINDSHIELD WIPERS.....	29
T.	ELECTRICAL.....	30
U.	GENERAL.....	30
V.	RADIO FREQUENCY SHIELDING-CAUTION!!!!.....	30
W.	FACTORY INSPECTION.....	31
X.	WARRANTY.....	31
Y.	SERVICE.....	32
Z.	MANUALS.....	32
AA.	SPECIFICATION FORMS.....	32
BB.	DELIVERY & PAYMENT.....	33
CC.	INSURANCE.....	33
DD.	BODY.....	34
EE.	TAILGATE.....	34
FF.	CONVEYOR ASSEMBLY.....	35
GG.	FRONT CROSS CONVEYOR.....	35
HH.	SPINNER ASSEMBLY.....	36
II.	STATIONARY CAB SHIELD.....	36
JJ.	MUDFLAPS.....	37

KK.	HOIST.....	37
LL.	HYDRAULIC SYSTEM .....	37
MM.	SNOWPLOW HITCH .....	44
NN.	WING .....	45
OO.	SUSPENSION .....	46
PP.	DUMP BODY INSTALLATION.....	46
QQ.	ROAD AIR TEMPERATURE SENSOR .....	47
RR.	FOLD-OUT LADDER .....	47
SS.	ROLL TARP .....	48
TT.	AUXILIARY HEADLAMP/TUR SIGNALS.....	48
UU.	CLEARANCE REFLECTORS.....	49
VV.	CONVEX MIRRORS.....	49
WW.	TOOLBOX .....	50
XX.	SAFETY EQUIPMENT.....	50
YY.	WARRANTY .....	51
ZZ.	GENERAL.....	51
AAA.	MANUALS .....	51
BBB.	SPECIFICATION FORM.....	52
CCC.	DELIVERY .....	52
DDD.	V-PLOW OPTION .....	53
EEE.	PLOW MOUNTING.....	53
FFF.	HEAVY DUTY SNOWPLOW HITCH ( IN LIEU OF HITCH FROM MAIN SPECIFICATION).....	53
GGG.	HIGH BENCHING WING ATTACHMENT.....	54
HHH.	SEVERE DUTY HIGH BENCHING WING ATTACHMEN.....	55
III.	PRE WET SYSTEM.....	55
JJJ.	TANK .....	56
KKK.	FITTINGS .....	56
LLL.	PUMP SYSTEM WITH METER.....	57
MMM.	MOUNTING SYSTEM.....	57
NNN.	NOZZLE DELIVERY SYSTEM .....	57
OOO.	GENERAL.....	58
PPP.	RIGHT WING MID MOUNT PATROL WING .....	58
QQQ.	PUSH ARM.....	59
RRR.	WING POST .....	59
SSS.	HYDRAULICS.....	60
TTT.	MANUALS .....	60
UUU.	COLOR .....	60
VVV.	WARRANTY .....	60
WWW.	LEFT HAND MID-MOUNT PATROL WING.....	61
XXX.	WING .....	61
YYY.	PUSH ARM.....	61
ZZZ.	WING POST .....	61
AAAA.	MOTOR VEHICLE INDUSTRIES REGULATION ACT .....	62
BBBB.	ANNUAL USAGE, ESTIMATED .....	62
CCCC.	USAGE REPORT .....	63
DDDD.	DELIVERY ARO .....	63
EEEE.	ORDERS .....	63
FFFF.	QUALITY .....	63
GGGG.	VIKING CIVES TOWPLOW .....	64
HHHH.	FRAME AND MOLDBOARDS .....	64
IIII.	WEIGHT .....	65
JJJJ.	AXLES .....	65
KKKK.	HYDRAULICS.....	65
LLLL.	LIGHTS.....	66
MMMM.	MATERIAL SPREADER .....	66
NNNN.	ROLL TARP .....	66
OOOO.	PRE WET SYSTEM.....	67
PPPP.	PRE WET PUMP SYSTEM WITH FLOW METER .....	67
QQQQ.	MANUALS .....	67
RRRR.	MISCELLANEOUS .....	68
SSSS.	WARRANTY .....	68
TTTT.	SPECIFICATION FORM.....	69

**Form A Vendor Contact Sheet ..... 70**  
**Form B Notification of Intent to Attend Pre-Bid Conference ..... 71**



## GLOSSARY OF TERMS

**Acceptance Test Procedure:** Benchmarks and other performance criteria, developed by the State or other sources of testing standards, for measuring the effectiveness of products or goods and the means used for testing such performance

**Addendum:** Something to be added or deleted to an existing document; a supplement

**Agency:** Using agencies shall mean and include all officers of the state, departments, bureaus, boards, commissions, councils, and institutions receiving legislative appropriations

**Agent/Representative:** A person authorized to act on behalf of another

**Amend:** To alter or change by adding, subtracting, or substituting

**Amendment:** A written correction or alteration to a document

**Appropriation:** Legislative authorization to expend public funds for a specific purpose. Money set apart for a specific use

**Automated Clearing House:** Electronic network for financial transactions in the United States

**Award:** All purchases, leases, or contracts which are based on competitive bids will be awarded according to the provisions in the solicitation

**Best and Final Offer:** In a competitive bid, the final offer submitted which contains vendor's most favorable terms for price

**Bid Bond:** An insurance agreement, accompanied by a monetary commitment, by which a third party (the surety) accepts liability and guarantees that the vendor will not withdraw the bid

**Bidder:** A vendor who submits an offer bid in response to a written solicitation

**Breach:** Violation of a contractual obligation by failing to perform or repudiation of one's own promise.

**Business:** Any corporation, partnership, individual, sole proprietorship, joint-stock company, joint venture, or any other private legal entity

**Business Day:** Any weekday, except State-recognized holidays

**Calendar Day:** Every day shown on the calendar including Saturdays, Sundays, and State/Federal holidays

**Cancellation:** To call off or revoke a bid, purchase order or contract without expectation of conducting or performing at a later time

**Catalog/Non-Core:** A printed or electronic list of products a vendor may provide at a discounted rate or discount off list price to the State. Initial contract award(s) is not based on Catalog/Non-Core items

**Central Processing Unit:** Any computer or computer system that is used by the State to store, process, or retrieve data or perform other functions using Operating Systems and applications software

**Change Order:** Document that provides amendments to an executed purchase order

**Collusion:** An agreement or cooperation between two or more persons or entities to accomplish a fraudulent, deceitful, or unlawful purpose

**Commodities:** Any equipment, material, supply or goods; anything movable or tangible that is provided or sold

**Commodities Description:** Detailed descriptions of the items to be purchased; may include information necessary to obtain the desired quality, type, color, size, shape, or special characteristics necessary to perform the work intended to produce the desired results

**Competition:** The effort or action of two or more commercial interests to obtain the same business from third parties

**Confidential Information:** Unless otherwise defined below, "Confidential Information" shall also mean proprietary trade secrets, academic and scientific research work which is in progress and unpublished, and other information which if released would give advantage to business competitors and serve no public purpose (see Neb. Rev. Stat. §84-712.05(3)). In accordance with Nebraska Attorney General Opinions 92068 and 97033, proof that information is proprietary requires identification of specific, named competitor(s) who would be advantaged by release of the information and the specific advantage the competitor(s) would receive

**Contract:** An agreement between two or more parties creating obligations that are enforceable or otherwise recognizable at law; the writing that sets forth such an agreement

**Contract Administration:** The management of the contract which includes and is not limited to contract signing, contract amendments and any necessary legal actions

**Contract Management:** The management of day to day activities at the agency which includes and is not limited to ensuring deliverables are received, specifications are met, handling meetings and making payments to the Vendor

**Contract Period:** The duration of the contract

**Vendor:** An individual or entity lawfully conducting business in the State, who seeks or agrees to provide goods or services under the terms of a written contract.

**Cooperative Purchasing:** The combining of requirements of two or more political entities to obtain advantages of volume purchases, reduction in administrative expenses or other public benefits

**Copyright:** A property right in an original work of authorship fixed in any tangible medium of expression, giving the holder the exclusive right to reproduce, adapt and distribute the work

**Core List:** Items specifically listed on the solicitation upon which a bid is evaluated for award .

**Critical Program Error:** Any Program Error, whether or not known to the State, which prohibits or significantly impairs use of the Licensed Software as set forth in the documentation and intended in the contract

**Customer Service:** The process of ensuring customer satisfaction by providing assistance and advice on those products or goods provided by a Vendor

**Default:** The omission or failure to perform a contractual duty

**Deviation:** Any proposed change(s) or alteration(s) to either the terms and conditions or deliverables within the scope of the written solicitation or contract

**Evaluation:** The process of examining an offer after opening to determine the vendor's responsibility, responsiveness to requirements, and to ascertain other characteristics of the offer that relate to determination of the successful award

**Evaluation Committee:** Committee(s) appointed by the requesting agency that advises and assists the procuring office in the evaluation of bid/s (offers made in response to written solicitations)

**Extension:** Continuance of a contract for a specified duration upon the agreement of the parties beyond the original Contract Period. Not to be confused with "Renewal Period"

**Free on Board (Destination):** The delivery charges are included in the quoted price and prepaid by the vendor. Vendor is responsible for all claims associated with damages during delivery of product

**Free on Board Point of Origin:** The delivery charges are not included in the quoted price and are the responsibility of the agency. Agency is responsible for all claims associated with damages during delivery of product

**Foreign Corporation:** A foreign corporation that was organized and chartered under the laws of another state, government, or country.

**Installation Date:** The date when the procedures described in "Installation by Vendor", and "Installation by State", as found in the solicitation, or contract are completed.

**Interested Party:** A person, acting in their personal capacity, or an entity entering into a contract or other agreement creating a legal interest therein

**Invalid Bid:** A bid that does not meet the requirements of the solicitation or cannot be evaluated against the other bids.

**Invitation to Bid :** A written solicitation utilized for obtaining competitive offers for Services or Goods

**Late Bid:** An offer received after the Opening Date and Time

**Licensed Software Documentation:** The user manuals and any other materials in any form or medium customarily provided by the Vendor to the users of the Licensed Software which will provide the State with sufficient information to operate, diagnose, and maintain the Licensed Software properly, safely, and efficiently

**Mandatory/Must:** Required, compulsory, or obligatory

**May:** Discretionary, permitted; used to express possibility

**Module (see System):** A collection of routines and data structures that perform a specific function of software

**Must:** See Mandatory/Must and Shall/Will/Must

**National Institute for Governmental Purchasing:** National Institute of Governmental Purchasing – Source used for assignment of universal commodity codes to goods and services

**Non-core:** See Catalog.

**Open Market Purchase:** Authorization may be given to an agency to purchase items above direct purchase authority due to the unique nature, price, quantity, location of the using agency, or time limitations by the AS Materiel Division, State Purchasing Bureau

**Opening Date and Time:** Specified date and time for the public opening of received, labeled, and sealed formal bids

**Operating System:** The control program in a computer that provides the interface to the computer hardware and peripheral devices, and the usage and allocation of memory resources, processor resources, input/output resources, and security resources

**Outsourcing:** The contracting out of a business process which an organization may have previously performed internally or has a new need for, to an independent organization from which the process is purchased back

**Payroll & Financial Center:** Electronic procurement system of record

**Performance Bond:** An insurance agreement, accompanied by a monetary commitment, by which a third party (the surety) accepts liability and guarantees that the Vendor fulfills any and all obligations under the contract

**Platform:** A specific hardware and Operating System combination that is different from other hardware and Operating System combinations to the extent that a different version of the Licensed Software product is required to execute properly in the environment established by such hardware and Operating System combination

**Point of Contact:** The person designated to receive communications and to communicate

**Pre-Bid Conference:** A meeting scheduled for the purpose of clarifying a written solicitation and related expectations

**Product:** Something that is distributed commercially for use or consumption and that is usually (1) tangible personal property, (2) the result of fabrication or processing, and (3) an item that has passed through a chain of commercial distribution before ultimate use or consumption

**Program Error:** Code in Licensed Software which produces unintended results or actions, or which produces results or actions other than those described in the specifications. A program error includes, without limitation, any Critical Program Error

**Program Set:** The group of programs and products, including the Licensed Software specified in the solicitation, plus any additional programs and products licensed by the State under the contract for use by the State

**Project:** The total scheme, program, or method worked out for the accomplishment of an objective, including all documentation, commodities, and goods to be provided under the contract

**Bid:** An offer, bid, or quote submitted by a vendor/vendor in a response to a written solicitation

**Proprietary Information:** Proprietary information is defined as trade secrets, academic and scientific research work which is in progress and unpublished, and other information which if released would give advantage to business competitors and service no public purpose (see Neb. Rev. Stat. § 84-712.05(3)). In accordance with Attorney General Opinions 92068 and 97033, proof that information is proprietary requires identification of specific named competitor(s) advantaged by release of the information and the demonstrated advantage the named competitor(s) would gain by the release of information

**Protest/Grievance:** A complaint about a governmental action or decision related to the solicitation or resultant contract, brought by a vendor who has timely submitted a bid response in connection with the award in question, to AS Materiel Division or another designated agency with the intention of achieving a remedial result

**Public Bid Opening:** The process of opening correctly submitted offers at the time and place specified in the written solicitation and in the presence of anyone who wished to attend

**Quote:** See Bid

**Recommended Hardware Configuration:** The data processing hardware (including all terminals, auxiliary storage, communication, and other peripheral devices) to the extent utilized by the State as recommended by the Vendor.

**Release Date:** The date of public release of the written solicitation to seek offers

**Renewal Period:** Optional contract periods subsequent to the original Contract Period for a specified duration with previously agreed to terms and conditions. Not to be confused with Extension

**Request for Information:** A general invitation to vendor is requesting information for a potential future solicitation. The RFI is typically used as a research and information gathering tool for preparation of a solicitation

**Responsible Vendor:** A Vendor who has the capability in all respects to perform fully and lawfully all requirements with integrity and reliability to assure good faith performance

**Responsive Vendor:** A Vendor who has submitted a bid which conforms to all requirements of the solicitation document

**Shall:** See Must

**Should:** Expected; suggested, but not necessarily mandatory

**Software License:** Legal instrument with or without printed material that governs the use or redistribution of licensed software

**Sole Source – Commodity:** When an item is available from only one source due to the unique nature of the requirement, its vendor, or market conditions

**Sole Source – Service:** A service of such a unique nature that the vendor selected is clearly and justifiably the only practical source to provide the service. Determination that the vendor selected is justifiably the sole source is based on either the uniqueness of the service or sole availability at the location required

**Specifications:** The detailed statement, especially of the measurements, quality, materials, and functional characteristics, or other items to be provided under a contract

**Statutory:** These clauses are controlled by state law and are not subject to negotiation

**Subcontractor:** Individual or entity with whom the vendor enters a contract to perform a portion of the work awarded to the vendor

**System (see Module):** Any collection or aggregation of two (2) or more Modules that is designed to function, or is represented by the Vendor as functioning or being capable of functioning, as an entity

**Termination:** Occurs when the contract expires or either party, pursuant to a power created by agreement or law puts an end to the contract prior to the stated expiration date. All obligations which are still executory on both sides are discharged but any right based on prior breach or performance survives

**Third-Party:** Any person or entity, including but not limited to fiduciaries, shareholders, owners, officers, managers, employees, legally disinterested persons, and sub-vendors or agents, and their employees. It shall not include any entity or person who is an interested Party to the contract or agreement

**Trade Secret:** Information, including, but not limited to, a drawing, formula, pattern, compilation, program, device, method, technique, code, or process that (a) derives independent economic value, actual or potential, from not being known to, and not being ascertainable by proper means by, other persons who can obtain economic value from its disclosure or use; and (b) is the subject of efforts that are reasonable under the circumstances to maintain its secrecy (see Neb. Rev. Stat. § 87-502(4))

**Trademark:** A word, phrase, logo, or other graphic symbol used by a manufacturer or vendor to distinguish its product from those of others, registered with the U.S. Patent and Trademark Office

**Upgrade:** Any change that improves or alters the basic function of a product of service

**Vendor Performance Report:** A report completed by the using agency and submitted to State Purchasing Bureau documenting products or services delivered or performed which exceed or fail to meet the terms of the purchase order, contract, and/or solicitation specifications.

**Vendor:** Inclusive term for any Bidder or Vendor.

**Will:** See Mandatory/Must/Shall

**Workday:** See Business Day

## ACRONYM LIST

**ARO** – After Receipt of Order

**ACH** – Automated Clearing House

**BAFO** – Best and Final Offer

**COI** – Certificate of Insurance

**CPU** – Central Processing Unit

**DAS** – Department of Administrative Services

**F.O.B.** – Free on Board

**ITB** – Invitation to Bid

**NIGP** – National Institute for Governmental Purchasing

**PA** – Participating Addendum

**RFI** – Request for Information

**RFP** – Request for Bid

**SPB** – State Purchasing Bureau

**PFC** – Payroll & Financial Center

**I. PROCUREMENT PROCEDURE**

**A. GENERAL INFORMATION**

The solicitation is designed to solicit bids from qualified Vendors who will be responsible for providing **TANDEM AXLE CHASSIS, MINIMUM 60,000 GVWR WITH RDS BODY & TOW PLOW, HYDRAULICS, PLOW HITCH.** at a competitive and reasonable cost. Terms and Conditions, Project Description and Scope of Work, Bid instructions, and Cost Bid Requirements may be found in Sections II through VI.

Bids shall conform to all instructions, conditions, and requirements included in the solicitation. Prospective Vendors are expected to carefully examine all documents, schedules, and requirements in this solicitation, and respond to each requirement in the format prescribed. Bids may be found non-responsive if they do not conform to the solicitation.

**B. PROCURING OFFICE AND COMMUNICATION WITH STATE STAFF AND EVALUATORS**

Procurement responsibilities related to this solicitation reside with SPB. The point of contact (POC) for the procurement is as follows:

ITB #                6581 OF  
Name:                Rob Taylor  
Agency:            State Purchasing Bureau  
Address:            1526 K Street, Suite 130  
                              Lincoln, NE 68508

Telephone:        402-471-6500

E-Mail:             [as.materielpurchasing@nebraska.gov](mailto:as.materielpurchasing@nebraska.gov)

From the date the solicitation is issued until the Intent to Award is issued, communication from the Vendor is limited to the POC listed above. After the Intent to Award is issued, the Vendor may communicate with individuals the State has designated as responsible for negotiating the contract on behalf of the State. No member of the State Government, employee of the State, or member of the Evaluation Committee is empowered to make binding statements regarding this solicitation. The POC will issue any answers, clarifications or amendments regarding this solicitation in writing. Only the SPB or awarding agency can award a contract. Vendors shall not have any communication with or attempt to communicate or influence any evaluator involved in this solicitation.

The following exceptions to these restrictions are permitted:

1. Contact made pursuant to pre-existing contracts or obligations;
2. Contact required by the schedule of events or an event scheduled later by POC; and
3. Contact required for negotiation and execution of the final contract.

The State reserves the right to reject a vendor's bid, withdraw an Intent to Award, or terminate a contract if the State determines there has been a violation of these procurement procedures.

**C. SCHEDULE OF EVENTS**

The State expects to adhere to the procurement schedule shown below, but all dates are approximate and subject to change.

	<b>ACTIVITY</b>	<b>DATE/TIME</b>
1.	Release solicitation	September 7, 2021
2.	Last day to submit written questions  <b>Upload electronic submissions via ShareFile to:</b>  <a href="https://nebraska.sharefile.com/r-r1ffc62454e2c4d9bbc3cf0add8d4ccda">https://nebraska.sharefile.com/r-r1ffc62454e2c4d9bbc3cf0add8d4ccda</a>	September 13, 2021
3.	State responds to written questions through a solicitation "Addendum" and/or "Amendment" to be posted to the Internet at: <a href="https://das.nebraska.gov/materiel/sites/purchasing.html">https://das.nebraska.gov/materiel/sites/purchasing.html</a>	September 15 <sup>th</sup> , 2021
4.	Last day to submit "Notification of Intent to Attend Pre-Bid Conference"	September 15 <sup>th</sup> , 2021
5.	<b>Mandatory Pre-Bid Conference (Electronic/Virtual)</b>  <b>Join Zoom Meeting</b> <a href="https://us02web.zoom.us/j/82945111036?pwd=SFNDQkZRZ0NNTGxaOXdtVWFOQmxkUT09">https://us02web.zoom.us/j/82945111036?pwd=SFNDQkZRZ0NNTGxaOXdtVWFOQmxkUT09</a>  <b>Meeting ID:</b> 829 4511 1036 <b>Passcode:</b> 330873  <i>* Registration Advisement: Bids will only be accepted from those Companies/Firms which properly register their attendance at this meeting by completing all of the required information on the State Registration Sheet.</i>	September 17, 2021 1:00 PM Central Time
6.	Last day to submit written questions after Pre-Bid Conference	September 24, 2021
7.	State responds to written questions through a solicitation "Addendum" and/or "Amendment" to be posted to the Internet at: <a href="https://das.nebraska.gov/materiel/sites/purchasing.html">https://das.nebraska.gov/materiel/sites/purchasing.html</a>	October 1 <sup>st</sup> , 2021
8.	<b>Electronic Bid Opening</b>  <b>Topic: 6581 OF TANDEM AXLE CHASSIS, MINIMUM 60,000 GVWR WITH RDS DUMP BODY &amp; TOW PLOW, HYDRAULICS, PLOW HITCH.</b>  <b>Join Zoom Meeting</b> <a href="https://us02web.zoom.us/j/87120179312?pwd=YXpKWHBzdDNOQStPZk1BMjNlVz1JEdz09">https://us02web.zoom.us/j/87120179312?pwd=YXpKWHBzdDNOQStPZk1BMjNlVz1JEdz09</a>  <b>Meeting ID:</b> 871 2017 9312 <b>Passcode:</b> 921167  <b>Upload electronic submissions via ShareFile to:</b>  <a href="https://nebraska.sharefile.com/r-r318f3b1159be43aca56b2df9cd225798">https://nebraska.sharefile.com/r-r318f3b1159be43aca56b2df9cd225798</a>	October 29 <sup>th</sup> , 2021 2:00 PM Central Time
9.	Post "Notification of Intent to Award" to Internet at: <a href="https://das.nebraska.gov/materiel/sites/purchasing.html">https://das.nebraska.gov/materiel/sites/purchasing.html</a>	TBD
10.	Contract award	TBD

**D. QUESTIONS AND ANSWERS**

Questions regarding the meaning or interpretation of any solicitation provision must be submitted to SPB and clearly marked "ITB Number 6581 OF; **TANDEM AXLE CHASSIS, MINIMUM 60,000 GVWR WITH RDS DUMP BODY & TOW PLOW, HYDRAULICS, PLOW HITCH** Questions". POC is not obligated to respond to questions that are received late per the Schedule of Events.

Vendors should present, as questions, any assumptions upon which the Vendor's bid is or might be developed. Bids will be evaluated without consideration of any known or unknown assumptions of a Vendor. The contract will not incorporate any known or unknown assumptions of a Vendor.

Questions can be sent via e-mail to [as.materielpurchasing@nebraska.gov](mailto:as.materielpurchasing@nebraska.gov). It is recommended however, that Vendors submit questions using the following format.

Questions should be uploaded using the following ShareFile link:

<https://nebraska.sharefile.com/r-r1ffc62454e2c4d9bbc3cf0add8d4ccda>

Solicitation Section Reference	Solicitation Page Number	Question

Written answers will be posted at <https://das.nebraska.gov/materiel/sites/purchasing.html> per the Schedule of Events.

**E. SECRETARY OF STATE/TAX COMMISSIONER REGISTRATION REQUIREMENTS (Statutory)**

All Vendors must be authorized to transact business in the State and comply with all Nebraska Secretary of State Registration requirements. The Vendor who is the recipient of an Intent to Award will be required to certify that it has complied and produce a true and correct copy of its current (within ninety (90) calendar days of the intent to award) Certificate or Letter of Good Standing, or in the case of a sole proprietorship, provide written documentation of sole proprietorship and the United States Citizenship Attestation Form, available on the DAS website at: <https://das.nebraska.gov/materiel/sites/purchasing.html>. This must be accomplished prior to execution of the contract.

**F. ETHICS IN PUBLIC CONTRACTING**

The State reserves the right to reject bids, withdraw an intent to award or award, or terminate a contract if a Vendor commits or has committed ethical violations, which include, but are not limited to:

1. Offering or giving, directly or indirectly, a bribe, fee, commission, compensation, gift, gratuity, or anything of value to any person or entity in an attempt to influence the bidding process;
2. Utilize the services of lobbyists, attorneys, political activists, or consultants to influence or subvert the bidding process;
3. Being considered for, presently being, or becoming debarred, suspended, ineligible, or excluded from contracting with any state or federal entity;
4. Submitting a bid on behalf of another party or entity;
5. Collude with any person or entity to influence the bidding process, submit sham bids, preclude bidding, fix pricing or costs, create an unfair advantage, subvert the bid, or prejudice the State.

The Vendor shall include this clause in any subcontract entered into for the exclusive purpose of performing this contract.

Vendor shall have an affirmative duty to report any violations of this clause by the Vendor throughout the bidding process, and throughout the term of this contract for the successful Vendor and their subcontractors.

**G. DEVIATIONS FROM THE INVITATION TO BID**

The requirements contained in the solicitation (Sections II through VI) become a part of the terms and conditions of the contract resulting from this solicitation. Any deviations from the solicitation in Sections II through VI must be clearly defined by the Vendor in its bid and, if accepted by the State, will become part of the contract. Any specifically defined deviations must not be in conflict with the basic nature of the solicitation, solicitation requirements, or applicable state or federal laws or statutes. "Deviation", for the purposes of this solicitation, means any proposed changes or alterations to either the contractual language or deliverables within the scope of this solicitation. The State discourages deviations and reserves the right to reject proposed deviations.



**H. SUBMISSION OF BIDS**

The Vendor is solely responsible for any variance if multiple bids are submitted. Bid responses should include the completed Form A, "Vendor Bid Point of Contact". Bids must reference the ITB number and be sent/uploaded to the specified Sharefile address which is linked in the schedule of events. The ITB number should be included in all correspondence. It is the vendor's responsibility to ensure the ITB is submitted by the date and time indicated in the Schedule of Events. Bids must be received in the State Purchasing Bureau by the date and time of the bid opening per the Schedule of Events. No late bids will be accepted.

The Invitation to Bid form must be manually signed in an indelible manner and returned by the bid opening date and time along with the vendor's Invitation to Bid along with any other requirements as stated in the Invitation to Bid document in order for the vendor's Invitation to Bid response to be evaluated.

It is the responsibility of the vendor to check the website for all information relevant to this Invitation to Bid to include addenda and/or amendments issued prior to the opening date. Website address is as follows: <https://das.nebraska.gov/materiel/sites/purchasing.html>

Emphasis should be concentrated on conformance to the ITB instructions, responsiveness to requirements, completeness, and clarity of content. If the vendor's bid is presented in such a fashion that makes evaluation difficult or overly time consuming the State reserves the right to reject the bid as non-conforming.

By signing the Invitation to Bid, the vendor guarantees compliance with the provisions stated in this ITB.

The State shall not incur any liability for any costs incurred by vendors in replying to this ITB, in the demonstrations and/or oral presentations, or in any other activity related to bidding on this ITB.

**I. BID PREPARATION COSTS**

The State shall not incur any liability for any costs incurred by Vendors in replying to this solicitation, including any activity related to bidding on this solicitation.

**J. FAILURE TO COMPLY WITH INVITATION TO BID**

Violation of the terms and conditions contained in this solicitation or any resultant contract, at any time before or after the award, shall be grounds for action by the State which may include, but is not limited to, the following:

1. Rejection of a Vendor's bid;
2. Withdrawal of the Intent to Award;
3. Withdrawal of the Award;
4. Negative Vendor Performance Report(s)
5. Termination of the resulting contract;
6. Legal action; or,
7. Suspension of the Vendor from further bidding with the State for the period of time relative to the seriousness of the violation, such period to be within the sole discretion of the State.

**K. BID CORRECTIONS**

A vendor may correct a mistake in a bid prior to the time of opening by giving written notice to the State of intent to withdraw the bid for modification or to withdraw the bid completely. Changing a bid after opening may be permitted if the change is made to correct a minor error that does not affect price, quantity, quality, delivery, or contractual conditions. In case of a mathematical error in extension of price, unit price shall govern.

**L. LATE BIDS**

Bids received after the time and date of the bid opening will be considered late bids. Late bids will be returned unopened, if requested by the Vendor and at Vendor's expense. The State is not responsible for bids that are late or lost regardless of cause or fault.

**M. BID OPENING**

Anyone may attend the opening. It is considered a public opening. The Buyer will read the names of the respondents. Depending upon the complexity of the bid for goods, the buyer may read the bids aloud or allow bids to be available for viewing by the public during the bid opening. Once the bid opening has concluded, the bids will not be available for viewing until the Intent to Award has been posted. An initial bid tabulation will be posted to the website as soon as feasible. Information identified as proprietary by the submitting vendor, in accordance with the solicitation and state statute, will not be posted. If the state determines submitted information should not be withheld, in accordance with the [Public Records Act](#), or if ordered to release any withheld information, said information may then be released. The submitting vendor will be notified of the release and it shall be the obligation of the submitting vendor to take further action, if it believes the information should not be released.

**N. INVITATION TO BID/BID REQUIREMENTS**

The bids will first be examined to determine if all requirements listed below have been addressed and whether further evaluation is warranted. Bids not meeting the requirements may be rejected as non-responsive. The requirements are:

1. Original Commodity ITB form signed using an indelible method (electronic signatures are acceptable);
2. Clarity and responsiveness of the bid;
3. Completed Sections II through VI;
4. Completed ITB Form or State's Cost Sheet.

**O. EVALUATION OF BIDS**

All bids that are responsive to the solicitation will be evaluated based on the following:

1. Cost Bid

**Neb. Rev. Stat. §81-161 allows the quality of performance of previous contracts to be considered when evaluating responses to competitively bid solicitations in determining the lowest responsible bidder.** Information obtained from any Vendor Performance Report (See Terms & Conditions, Section H) may be used in evaluating responses to solicitations for goods and services to determine the best value for the State.

**Neb. Rev. Stat. §73-107 allows for a preference for a resident disabled veteran or business located in a designated enterprise zone.** When a state contract is to be awarded to the lowest responsible vendor, a resident disabled veteran or a business located in a designated enterprise zone under the Enterprise Zone Act shall be allowed a preference over any other resident or nonresident vendor, if all other factors are equal.

**Resident disabled veterans means any person (a) who resides in the State of Nebraska, who served in the United States Armed Forces, including any reserve component or the National Guard, who was discharged or otherwise separated with a characterization of honorable or general (under honorable conditions), and who possesses a disability rating letter issued by the United States Department of Veterans Affairs establishing a service-connected disability or a disability determination from the United States Department of Defense and (b)(i) who owns and controls a business or, in the case of a publicly owned business, more than fifty percent of the stock is owned by one or more persons described in subdivision (a) of this subsection and (ii) the management and daily business operations of the business are controlled by one or more persons described in subdivision(a) of this subsection. Any contract entered into without compliance with this section shall be null and void.**

Therefore, if a resident disabled veteran or business located in a designated enterprise zone submits a bid in accordance with Neb. Rev. Stat. §73-107 and has so indicated on the ITB cover page under "Vendor must complete the following" requesting priority/preference to be considered in the award of this contract, the following will need to be submitted by the vendor within ten (10) business days of request:

1. Documentation from the United States Armed Forces confirming service;
2. Documentation of discharge or otherwise separated characterization of honorable or general (under honorable conditions);
3. Disability rating letter issued by the United States Department of Veterans Affairs establishing a service-connected disability or a disability determination from the United States Department of Defense; and
4. Documentation which shows ownership and control of a business or, in the case of a publicly owned business, more than fifty percent of the stock is owned by one or more persons described in subdivision (a) of this subsection; and the management and daily business operations of the business are controlled by one or more persons described in subdivision (a) of this subsection.

Failure to submit the requested documentation within ten (10) business days of notice will disqualify the vendor from consideration of the preference.

**P. REFERENCE AND CREDIT CHECKS**

The State reserves the right to conduct and consider reference and credit checks. The State reserves the right to use third parties to conduct reference and credit checks. By submitting a bid in response to this solicitation, the vendor grants to the State the right to contact or arrange a visit in person with any or all of the vendor's clients. Reference and credit checks may be grounds to reject a bid, withdraw an intent to award, or rescind the award of a contract.

**Q. AWARD**

The State reserves the right to evaluate bids and award contracts in a manner utilizing criteria selected at the State's discretion and in the State's best interest. After evaluation of the bids, or at any point in the solicitation process, the State of Nebraska may take one or more of the following actions:

1. Amend the solicitation;
2. Extend the time of or establish a new bid opening time;
3. Waive deviations or errors in the State's solicitation process and in vendor bids that are not material, do not compromise the solicitation process or a vendor's bid, and do not improve a vendor's competitive position;
4. Accept or reject a portion of or all of a bid;
5. Accept or reject all bids;
6. Withdraw the solicitation;
7. Elect to rebid the solicitation;
8. Award single lines or multiple lines to one or more vendors; or,
9. Award one or more all-inclusive contracts.

The solicitation does not commit the State to award a contract. Once intent to award decision has been determined, it will be posted to the Internet at:

<https://das.nebraska.gov/materiel/sites/purchasing.html>

Any protests must be filed by a vendor within ten (10) business days after the intent to award decision is posted to the Internet. Grievance and protest procedure are available on the Internet at:

<https://das.nebraska.gov/materiel/sites/purchasing.html>

**R. SPECIFICATIONS**

Any manufacturer's names, trade names, brand names, information and/or catalog numbers listed in a specification are for reference and not intended to limit competition, but will be used as the standard by which equivalent material offered will be judged. The Materiel Administrator will be the sole judge of equivalency. The Vendor may offer any brands which meets or exceeds the specification. When a specific product is required, the solicitation will so state. Any item bid is to be the latest current model under standard production at the time of order. No used or refurbished equipment will be accepted, unless otherwise stated.

**S. ALTERNATE/EQUIVALENT BIDS**

Vendor may offer bids which are at variance from the express specifications of the solicitation. The State reserves the right to consider and accept such bids if, in the judgment of the Materiel Administrator, the bid will result in goods and/or services equivalent to or better than those which would be supplied in the original bid specifications. Vendor must indicate on the solicitation the manufacturer's name, number and shall submit with their bid, sketches, descriptive literature and/or complete specifications. Reference to literature submitted with a previous bid will not satisfy this provision. Bids which do not comply with these requirements are subject to rejection. In the absence of any stated deviation or exception, the bid will be accepted as in strict compliance with all terms, conditions and specification, and the Vendor shall be held liable therefore.

**T. LUMP SUM OR "ALL OR NONE" BIDS**

The State reserves the right to purchase item-by-item, by groups or as a total when the State may benefit by so doing. Vendors may submit a bid on an "all or none" or "lump sum" basis, but should also submit a bid on an item-by-item basis. The term "all or none" means a conditional bid which requires the purchase of all items on which bids are offered and Vendor declines to accept award on individual items; a "lump sum" bid is one in which the Vendor offers a lower price than the sum of the individual bids if all items are purchased, but agrees to deliver individual items at the prices quoted.

**U. EMAIL SUBMISSIONS**

SPB will not accept bids by email, voice, or telephone bids **except** for one-time purchases under \$50,000.00.

**V. BID TABULATIONS**

Bid tabulations are available on the website at: <https://das.nebraska.gov/materiel/sites/purchasing.html>.

**W. REJECTION OF BIDS**

The State reserves the right to reject any or all bids, wholly or in part, in the best interest of the State.

**X. RESIDENT BIDDER**

Pursuant to Neb. Rev. Stat. §§ 73-101.01 through 73-101.02, a Resident Bidder shall be allowed a preference against a Non-resident Bidder from a state which gives or requires a preference to Bidders from that state. The preference

shall be equal to the preference given or required by the state of the Nonresident Bidders. Where the lowest responsible bid from a resident Bidder is equal in all respects to one from a nonresident Bidder from a state which has no preference law, the resident Bidder shall be awarded the contract. The provision of this preference shall not apply to any contract for any project upon which federal funds would be withheld because of the provisions of this preference.

**Y. PRE-PROPOSAL CONFERENCE**

A pre-proposal conference will be held per the Schedule of Events. Attendance at the pre-proposal conference is mandatory in order to submit a bid. Vendors will have an opportunity to ask questions at the conference to assist in the clarification and understanding of the solicitation requirements. Questions that have a material impact on the solicitation or solicitation process, and relevant to all Vendors will be answered in writing and posted at <http://das.nebraska.gov/materiel/sites/purchasing.html>. An answer must be posted to be binding on the State. The State will attempt to provide verbal answers to questions that do not impact the ITB or process, and are only of interest to an individual contractor during the conference. If a Contractor feels it necessary to have a binding answer to a question that was answered verbally, the question should be submitted in writing per the Schedule of Events.

**Z. NOTICE OF INTENT TO ATTEND MANDATORY PRE-BID CONFERENCE**

Vendors should notify SPB of their intent to attend by submitting a "Notification of Intent to Attend the Pre-Bid Conference Form" (see Form B) by email at [as.materielpurchasing@nebraska.gov](mailto:as.materielpurchasing@nebraska.gov)

**II. TERMS AND CONDITIONS**

**Vendors should complete Section II through VI as part of their bid.** Vendor is expected to read the Terms and Conditions and must initial either accept, reject, or reject and provide alternative language for each clause. The Vendor should also provide an explanation of why the Vendor rejected the clause or rejected the clause and provided alternate language using "Track Changes". Upon request an electronic copy of the bid with "Track Changes" must be submitted in an editable Word format. By signing the solicitation, Vendor is agreeing to be legally bound by all the accepted terms and conditions, and any proposed alternative terms and conditions submitted with the bid. The State reserves the right to negotiate rejected or proposed alternative language. If the State and Vendor fail to agree on the final Terms and Conditions, the State reserves the right to reject the bid. The State is soliciting bids in response to the solicitation. The State reserves the right to reject bids that attempt to substitute the Vendor's commercial contracts and/or documents for this solicitation.

The Vendor should submit with their bid any license, user agreement, service level agreement, or similar documents that the Vendor wants incorporated in the Contract. Upon notice of Intent to Award, the Vendor must submit a copy of these documents in an editable Word format. The State will not consider incorporation of any document not submitted with the Vendor's bid. These documents shall be subject to negotiation and will be incorporated as addendums if agreed to by the Parties.

If a conflict or ambiguity arises after the addendums have been negotiated and agreed to, the addendums shall be interpreted as follows:

1. If only one (1) Party's document has a particular clause then that clause shall control;
2. If both Party's documents have a similar clause, but the clauses do not conflict, the clauses shall be read together;
3. If both Party's documents have a similar clause, but the clauses conflict, the State's clause shall control.

**A. GENERAL**

Accept (Initial)	Reject (Initial)	Reject & Provide Alternative (Initial)	NOTES/COMMENTS:

The contract resulting from this solicitation shall incorporate the following documents:

1. Invitation to Bid and Addenda;
2. Amendments to the solicitation;
3. Questions and Answers;
4. Vendor's bid response;
5. The executed Contract and any Addenda, if applicable, and properly submitted documents; and,
6. Amendments to the Contract

These documents constitute the entirety of the contract.

Unless otherwise specifically stated in a future contract amendment, in case of any conflict between the incorporated documents, the documents shall govern in the following order of preference with number one (1) receiving preference over all other documents and with each lower numbered document having preference over any higher numbered document: 1) Amendment to the executed Contract with the most recent dated amendment having the highest priority, 2) executed Contract and any attached Addenda, 3) Amendments to solicitation and any Questions and Answers, 4) the original solicitation document and any Addenda, and 5) the Vendor's submitted Bid.

Any ambiguity or conflict in the contract discovered after its execution, not otherwise addressed herein, shall be resolved in accordance with the rules of contract interpretation as established in the State.

**B. NOTIFICATION**

Accept (Initial)	Reject (Initial)	Reject & Provide Alternative (Initial)	NOTES/COMMENTS:

Vendor and State shall identify the contract manager who shall serve as the point of contact for the executed contract.

Communications regarding the executed contract shall be in writing and shall be deemed to have been given if delivered personally or mailed, by U.S. Mail, postage prepaid, return receipt requested, to the parties at their respective addresses or at such other addresses as may be specified in writing by either of the parties. All notices, requests, or communications shall be deemed effective upon personal delivery or five (5) calendar days following deposit in the mail.

Either party may change its address for notification purposes by giving notice of the change, and setting forth the new address and an effective date.

**C. NOTICE (POC)**

The State reserves the right to appoint a Buyer's Representative to manage [or assist the Buyer in managing] the contract on behalf of the State. The Buyer's Representative will be appointed in writing, and the appointment document will specify the extent of the Buyer's Representative authority and responsibilities. If a Buyer's Representative is appointed, the Vendor will be provided a copy of the appointment document, and is expected to cooperate accordingly with the Buyer's Representative. The Buyer's Representative has no authority to bind the State to a contract, amendment, addendum, or other change or addition to the contract.

**D. GOVERNING LAW (Statutory)**

Notwithstanding any other provision of this contract, or any amendment or addendum(s) entered into contemporaneously or at a later time, the parties understand and agree that, (1) the State of Nebraska is a sovereign state and its authority to contract is therefore subject to limitation by the State's Constitution, statutes, common law, and regulation; (2) this contract will be interpreted and enforced under the laws of the State of Nebraska; (3) any action to enforce the provisions of this contract must be brought in the State of Nebraska per state law; (4) the person signing this contract on behalf of the State of Nebraska does not have the authority to waive the State's sovereign immunity, statutes, common law, or regulations; (5) the indemnity, limitation of liability, remedy, and other similar provisions of the final contract, if any, are entered into subject to the State's Constitution, statutes, common law, regulations, and sovereign immunity; and, (6) all terms and conditions of the final contract, including but not limited to the clauses concerning third-party use, licenses, warranties, limitations of liability, governing law and venue, usage verification, indemnity, liability, remedy or other similar provisions of the final contract are entered into specifically subject to the State's Constitution, statutes, common law, regulations, and sovereign immunity.

The Parties must comply with all applicable local, state and federal laws, ordinances, rules, orders, and regulations.

**E. AMENDMENT**

This Contract may be amended in writing, within scope, upon the agreement of both parties.

**F. CHANGE ORDERS OR SUBSTITUTIONS**

Accept (Initial)	Reject (Initial)	Reject & Provide Alternative (Initial)	NOTES/COMMENTS:

The State and the Vendor, upon the written agreement, may make changes to the contract within the general scope of the solicitation. Changes may involve specifications, the quantity of work, or such other items as the State may find necessary or desirable. Corrections of any deliverable, service, or work required pursuant to the contract shall not be deemed a change. The Vendor may not claim forfeiture of the contract by reasons of such changes.

The Vendor shall prepare a written description of the work required due to the change and an itemized cost sheet for the change. Changes in work and the amount of compensation to be paid to the Vendor shall be determined in accordance with applicable unit prices if any, a pro-rated value, or through negotiations. The State shall not incur a

price increase for changes that should have been included in the Vendor's bid, were foreseeable, or result from difficulties with or failure of the Vendor's bid or performance.

No change shall be implemented by the Vendor until approved by the State, and the Contract is amended to reflect the change and associated costs, if any. If there is a dispute regarding the cost, but both parties agree that immediate implementation is necessary, the change may be implemented, and cost negotiations may continue with both Parties retaining all remedies under the contract and law.

In the event any product is discontinued or replaced upon mutual consent during the contract period or prior to delivery, the State reserves the right to amend the contract or purchase order to include the alternate product at the same price.

**\*\*\*Vendor will not substitute any item that has been awarded without prior written approval of SPB\*\*\***

**G. VENDOR PERFORMANCE REPORT(S)**

Accept (Initial)	Reject (Initial)	Reject & Provide Alternative (Initial)	NOTES/COMMENTS:

The State may document any instance(s) of products or services delivered or performed which exceed or fail to meet the terms of the purchase order, contract, and/or solicitation specifications. The State Purchasing Bureau may contact the Vendor regarding any such report. Vendor performance report(s) will become a part of the permanent record of the Vendor.

**H. NOTICE OF POTENTIAL VENDOR BREACH**

Accept (Initial)	Reject (Initial)	Reject & Provide Alternative (Initial)	NOTES/COMMENTS:

If Vendor breaches the contract or anticipates breaching the contract, the Vendor shall immediately give written notice to the State. The notice shall explain the breach or potential breach, a proposed cure, and may include a request for a waiver of the breach if so desired. The State may, in its discretion, temporarily or permanently waive the breach. By granting a waiver, the State does not forfeit any rights or remedies to which the State is entitled by law or equity, or pursuant to the provisions of the contract. Failure to give immediate notice, however, may be grounds for denial of any request for a waiver of a breach.

**I. BREACH**

Accept (Initial)	Reject (Initial)	Reject & Provide Alternative (Initial)	NOTES/COMMENTS:

Either Party may terminate the contract, in whole or in part, if the other Party breaches its duty to perform its obligations under the contract in a timely and proper manner. Termination requires written notice of default and a thirty (30) calendar day (or longer at the non-breaching Party's discretion considering the gravity and nature of the default) cure period. Said notice shall be delivered by Certified Mail, Return Receipt Requested, or in person with proof of delivery. Allowing time to cure a failure or breach of contract does not waive the right to immediately terminate the contract for the same or different contract breach which may occur at a different time.

In case of breach by the Vendor, the State may, without unreasonable delay, make a good faith effort to make a reasonable purchase or contract to purchased goods in substitution of those due from the vendor. The State may recover from the Vendor as damages the difference between the costs of covering the breach. Notwithstanding any clause to the contrary, the State may also recover the contract price together with any incidental or consequential damages defined in UCC Section 2-715, but less expenses saved in consequence of Vendor's breach. OR In case

of default of the Vendor, the State may contract the service from other sources and hold the Vendor responsible for any excess cost occasioned thereby.

The State's failure to make payment shall not be a breach, and the Vendor shall retain all available statutory remedies. (See Indemnity - Self-Insurance and Payment)

**J. NON-WAIVER OF BREACH**

Accept (Initial)	Reject (Initial)	Reject & Provide Alternative (Initial)	NOTES/COMMENTS:

The acceptance of late performance with or without objection or reservation by a Party shall not waive any rights of the Party nor constitute a waiver of the requirement of timely performance of any obligations remaining to be performed.

**K. SEVERABILITY**

Accept (Initial)	Reject (Initial)	Reject & Provide Alternative (Initial)	NOTES/COMMENTS:

If any term or condition of the contract is declared by a court of competent jurisdiction to be illegal or in conflict with any law, the validity of the remaining terms and conditions shall not be affected, and the rights and obligations of the parties shall be construed and enforced as if the contract did not contain the provision held to be invalid or illegal.

**L. INDEMNIFICATION**

Accept (Initial)	Reject (Initial)	Reject & Provide Alternative (Initial)	NOTES/COMMENTS:

**1. GENERAL**

The Vendor agrees to defend, indemnify, and hold harmless the State and its employees, volunteers, agents, and its elected and appointed officials ("the indemnified parties") from and against any and all claims, liens, demands, damages, liability, actions, causes of action, losses, judgments, costs, and expenses of every nature, including investigation costs and expenses, settlement costs, and attorney fees and expenses ("the claims"), sustained or asserted against the State for personal injury, death, or property loss or damage, arising out of, resulting from, or attributable to the willful misconduct, negligence, error, or omission of the Vendor, its employees, Subcontractors, consultants, representatives, and agents, resulting from this contract, except to the extent such Vendor liability is attenuated by any action of the State which directly and proximately contributed to the claims.

**2. INTELLECTUAL PROPERTY**

The Vendor agrees it will, at its sole cost and expense, defend, indemnify, and hold harmless the indemnified parties from and against any and all claims, to the extent such claims arise out of, result from, or are attributable to, the actual or alleged infringement or misappropriation of any patent, copyright, trade secret, trademark, or confidential information of any third party by the Vendor or its employees, Subcontractors, consultants, representatives, and agents; provided, however, the State gives the Vendor prompt notice in writing of the claim. The Vendor may not settle any infringement claim that will affect the State's use of the Licensed Software without the State's prior written consent, which consent may be withheld for any reason.

If a judgment or settlement is obtained or reasonably anticipated against the State's use of any intellectual property for which the Vendor has indemnified the State, the Vendor shall, at the Vendor's sole cost and expense, promptly modify the item or items which were determined to be infringing, acquire a license or



licenses on the State's behalf to provide the necessary rights to the State to eliminate the infringement, or provide the State with a non-infringing substitute that provides the State the same functionality. At the State's election, the actual or anticipated judgment may be treated as a breach of warranty by the Vendor, and the State may receive the remedies provided under this solicitation.

**3. SELF-INSURANCE (Statutory)**

The State is self-insured for any loss and purchases excess insurance coverage pursuant to Neb. Rev. Stat. § 81-8,239.01 (Reissue 2008). If there is a presumed loss under the provisions of this contract, Vendor may file a claim with the Office of Risk Management pursuant to Neb. Rev. Stat. §§ 81-8,829 through 81-8,306 for review by the State Claims Board. The State retains all rights and immunities under the State Miscellaneous (Section 81-8,294), Tort (Section 81-8,209), and Contract Claim Acts (Section 81-8,302), as outlined in Neb. Rev. Stat. § 81-8,209 et seq. and under any other provisions of law and accepts liability under this contract to the extent provided by law.

**M. ATTORNEY'S FEES**

Accept (Initial)	Reject (Initial)	Reject & Provide Alternative (Initial)	NOTES/COMMENTS:

In the event of any litigation, appeal, or other legal action to enforce any provision of the contract, the Parties agree to pay all expenses of such action, as permitted by law and if ordered by the court, including attorney's fees and costs, if the other party prevails.

**N. ASSIGNMENT, SALE, OR MERGER**

Accept (Initial)	Reject (Initial)	Reject & Provide Alternative (Initial)	NOTES/COMMENTS:

Either party may assign the contract upon mutual written agreement of the other party. Such agreement shall not be unreasonably withheld.

The Vendor retains the right to enter into a sale, merger, acquisition, internal reorganization, or similar transaction involving Vendor's business. Vendor agrees to cooperate with the State in executing amendments to the contract to allow for the transaction. If a third party or entity is involved in the transaction, the Vendor will remain responsible for performance of the contract until such time as the person or entity involved in the transaction agrees in writing to be contractually bound by this contract and perform all obligations of the contract.

**O. CONTRACTING WITH OTHER POLITICAL SUB-DIVISIONS OF THE STATE OR ANOTHER STATE**

Accept (Initial)	Reject (Initial)	Reject & Provide Alternative (Initial)	NOTES/COMMENTS:

The Vendor may, but shall not be required to, allow agencies, as defined in Neb. Rev. Stat. § 81-145, to use this contract. The terms and conditions, including price, of the contract may not be amended. The State shall not be contractually obligated or liable for any contract entered into pursuant to this clause.

The Vendor may, but shall not be required to, allow other states, agencies or divisions of other states, or political subdivisions of other states to use this contract. The terms and conditions, including price, of this contract shall apply to any such contract, but may be amended upon mutual consent of the Parties. The State of Nebraska shall not be contractually or otherwise obligated or liable under any contract entered into pursuant to this clause. The State shall be notified if a contract is executed based upon this contract.

**P. FORCE MAJEURE**

Accept (Initial)	Reject (Initial)	Reject & Provide Alternative within Solicitation (Initial)	NOTES/COMMENTS:

Neither party shall be liable for any costs or damages, or for default resulting from its inability to perform any of its obligations under the contract due to a natural or man-made event outside the control and not the fault of the affected party ("Force Majeure Event"). The Party so affected shall immediately make a written request for relief to the other party, and shall have the burden of proof to justify the request. The other Party may be granted the relief requested; relief may not be unreasonably withheld. Labor disputes with the impacted party's own employees will not be considered a Force Majeure Event.

**Q. CONFIDENTIALITY**

Accept (Initial)	Reject (Initial)	Reject & Provide Alternative within Solicitation (Initial)	NOTES/COMMENTS:

All materials and information provided by the Parties or acquired by a Party on behalf of the other Party shall be regarded as confidential information. All materials and information provided or acquired shall be handled in accordance with federal and state law, and ethical standards. Should said confidentiality be breached by a Party, the Party shall notify the other Party immediately of said breach and take immediate corrective action.

It is incumbent upon the Parties to inform their officers and employees of the penalties for improper disclosure imposed by the Privacy Act of 1974, 5 U.S.C. 552a. Specifically, 5 U.S.C. 552a (i)(1), which is made applicable by 5 U.S.C. 552a (m)(1), provides that any officer or employee, who by virtue of his/her employment or official position has possession of or access to agency records which contain individually identifiable information, the disclosure of which is prohibited by the Privacy Act or regulations established thereunder, and who knowing that disclosure of the specific material is prohibited, willfully discloses the material in any manner to any person or agency not entitled to receive it, shall be guilty of a misdemeanor and fined not more than \$5,000.

If it provides, under the terms of this contract and on behalf of the State, health and human services to individuals; service delivery; service coordination; or case management, Vendor shall submit to the jurisdiction of the Office of Public Counsel, pursuant to Neb. Rev. Stat. § 81-8,240 et seq. This section shall survive the termination of this

**R. EARLY TERMINATION**

Accept (Initial)	Reject (Initial)	Reject & Provide Alternative (Initial)	NOTES/COMMENTS:

The contract may be terminated as follows:

1. The State and the Vendor, by mutual written agreement, may terminate the contract at any time.
2. The State, at its sole discretion, may terminate the contract for any reason upon thirty (30) calendar day's written notice to the Vendor. Such termination shall not relieve the Vendor of warranty or other service obligations incurred under the terms of the contract. In the event of termination the Vendor shall be entitled to payment, determined on a pro rata basis, for products or services satisfactorily performed or provided.
3. The State may terminate the contract immediately for the following reasons:
  - a. if directed to do so by statute;

- b. Vendor has made an assignment for the benefit of creditors, has admitted in writing its inability to pay debts as they mature, or has ceased operating in the normal course of business;
- c. a trustee or receiver of the Vendor or of any substantial part of the Vendor's assets has been appointed by a court;
- d. fraud, misappropriation, embezzlement, malfeasance, misfeasance, or illegal conduct pertaining to performance under the contract by its Vendor, its employees, officers, directors, or shareholders;
- e. an involuntary proceeding has been commenced by any party against the Vendor under any one of the chapters of Title 11 of the United States Code and (i) the proceeding has been pending for at least sixty (60) calendar days; or (ii) the Vendor has consented, either expressly or by operation of law, to the entry of an order for relief; or (iii) the Vendor has been decreed or adjudged a debtor;
- f. a voluntary petition has been filed by the Vendor under any of the chapters of Title 11 of the United States Code;
- g. Vendor intentionally discloses confidential information;
- h. Vendor has or announces it will discontinue support of the deliverable; and,
- i. In the event funding is no longer available.

**S. CONTRACT CLOSEOUT**

Accept (Initial)	Reject (Initial)	Reject & Provide Alternative (Initial)	NOTES/COMMENTS:

Upon termination of the contract for any reason the Vendor shall within thirty (30) days, unless stated otherwise herein:

1. Transfer all completed or partially completed deliverables to the State;
2. Transfer ownership and title to all completed or partially completed deliverables to the State;
3. Return to the State all information and data, unless the Vendor is permitted to keep the information or data by contract or rule of law. Vendor may retain one copy of any information or data as required to comply with applicable work product documentation standards or as are automatically retained in the course of Vendor's routine back up procedures;
4. Cooperate with any successor contactor, person or entity in the assumption of any or all of the obligations of this contract;
5. Cooperate with any successor contactor, person or entity with the transfer of information or data related to this contract;
6. Return or vacate any state owned real or personal property; and,
7. Return all data in a mutually acceptable format and manner.

Nothing in this Section should be construed to require the Vendor to surrender intellectual property, real or person property, or information or data owned by the Vendor for which the State has no legal claim.

**III. VENDOR DUTIES**

**A. INDEPENDENT VENDOR / OBLIGATIONS**

Accept (Initial)	Reject (Initial)	Reject & Provide Alternative (Initial)	NOTES/COMMENTS:

It is agreed that the Vendor is an independent vendor and that nothing contained herein is intended or should be construed as creating or establishing a relationship of employment, agency, or a partnership.

The Vendor is solely responsible for fulfilling the contract. The Vendor or the Vendor's representative shall be the sole point of contact regarding all contractual matters.

The Vendor shall secure, at its own expense, all personnel required to perform the services under the contract. The personnel the Vendor uses to fulfill the contract shall have no contractual or other legal relationship with the State; they shall not be considered employees of the State and shall not be entitled to any compensation, rights or benefits from the State, including but not limited to, tenure rights, medical and hospital care, sick and vacation leave, severance pay, or retirement benefits.

By-name personnel commitments made in the Vendor's bid shall not be changed without the prior written approval of the State. Replacement of these personnel, if approved by the State, shall be with personnel of equal or greater ability and qualifications.

The Vendor warrants that all persons assigned to the project shall be employees of the Vendor or a Subcontractor, and shall be fully qualified to perform the work required herein. Personnel employed by the Vendor or a subcontractor to fulfill the terms of the contract shall remain under the sole direction and control of the Vendor or the subcontractor respectively.

With respect to its employees, the Vendor agrees to be solely responsible for the following:

1. Any and all pay, benefits, and employment taxes and/or other payroll withholding;
2. Any and all vehicles used by the Vendor's employees, including all insurance required by state law;
3. Damages incurred by Vendor's employees within the scope of their duties under the contract;
4. Maintaining Workers' Compensation and health insurance that complies with state and federal law and submitting any reports on such insurance to the extent required by governing law;
5. Determining the hours to be worked and the duties to be performed by the Vendor's employees; and,
6. All claims on behalf of any person arising out of employment or alleged employment (including without limit claims of discrimination alleged against the Vendor, its officers, agents, or subcontractors or subcontractor's employees).

If the Vendor intends to utilize any subcontractor, the Subcontractor's level of effort, tasks, and time allocation must be clearly defined in the Vendor's bid. The Vendor shall agree that it will not utilize any Subcontractors not specifically included in its bid in the performance of the contract without the prior written authorization of the State.

The State reserves the right to require the Vendor to reassign or remove from the project any Vendor or Subcontractor employee.

Vendor shall insure that the terms and conditions contained in any contract with a sub-vendor does not conflict with the terms and conditions of this contract.

The Vendor shall include a similar provision, for the protection of the State, in the contract with any Subcontractor engaged to perform work on this contract.

**B. EMPLOYEE WORK ELIGIBILITY STATUS**

The Vendor is required and hereby agrees to use a federal immigration verification system to determine the work eligibility status of employees physically performing work within the State. A federal immigration verification system means the electronic verification of the work authorization program authorized by the Illegal Immigration Reform and Immigrant Responsibility Act of 1996, 8 U.S.C. 1324a, known as the E-Verify Program, or an equivalent federal program designated by the United States Department of Homeland Security or other federal agency authorized to verify the work eligibility status of an employee.

If the Vendor is an individual or sole proprietorship, the following applies:

1. The Vendor must complete the United States Citizenship Attestation Form, available on the DAS website at <https://das.nebraska.gov/materiel/sites/purchasing.html>

The completed United States Attestation Form should be submitted with the solicitation response.

1. If the Vendor indicates on such attestation form that he or she is a qualified alien, the Vendor agrees to provide the U.S. Citizenship and Immigration Services documentation required to verify the Vendor's lawful presence in the United States using the Systematic Alien Verification for Entitlements (SAVE) Program.
2. The Vendor understands and agrees that lawful presence in the United States is required and the Vendor may be disqualified or the contract terminated if such lawful presence cannot be verified as required by Neb. Rev. Stat. § 4-108.

**C. COMPLIANCE WITH CIVIL RIGHTS LAWS AND EQUAL OPPORTUNITY EMPLOYMENT / NONDISCRIMINATION (Statutory)**

The Vendor shall comply with all applicable local, state, and federal statutes and regulations regarding civil rights laws and equal opportunity employment. The Nebraska Fair Employment Practice Act prohibits Vendors of the State, and their Subcontractors, from discriminating against any employee or applicant for employment, with respect to hire, tenure, terms, conditions, compensation, or privileges of employment because of race, color, religion, sex, disability, marital status, or national origin (Neb. Rev. Stat. §§ 48-1101 through 48-1125). The Vendor guarantees compliance with the Nebraska Fair Employment Practice Act, and breach of this provision shall be regarded as a material breach of contract. The Vendor shall insert a similar provision in all Subcontracts for goods or services to be covered by any contract resulting from this solicitation.

**D. COOPERATION WITH OTHER VENDORS**

Accept (Initial)	Reject (Initial)	Reject & Provide Alternative (Initial)	NOTES/COMMENTS:

Vendor may be required to work with or in close proximity to other vendors or individuals that may be working on the same or different projects. The Vendor shall agree to cooperate with such other vendors or individuals, and shall not commit or permit any act which may interfere with the performance of work by any other vendor or individual. Vendor is not required to compromise Vendor's intellectual property or proprietary information unless expressly required to do so by this contract.

**E. DISCOUNTS**

Prices quoted shall be inclusive of ALL trade discounts. Cash discount terms of less than thirty (30) days will not be considered as part of the bid. Cash discount periods will be computed from the date of receipt of a properly executed claim voucher or the date of completion of delivery of all items in a satisfactory condition, whichever is later.

**F. PRICES**

Prices quoted shall be net, including transportation and delivery charges fully prepaid by the vendor, F.O.B. destination named in the solicitation. No additional charges will be allowed for packing, packages, or partial delivery costs. When an arithmetic error has been made in the extended total, the unit price will govern.

Prices submitted on the cost bid form, once accepted by the State, shall remain fixed for the first one hundred and eighty (180 days) of the contract. Any request for a price increase must be submitted in writing to the State Purchasing Bureau a minimum of thirty (30) days prior to the proposed effective date. Documentation may be required by the State to support the price increase. Failure to provide such documentation could be grounds to delay or reject price increase requests.

**The State reserves the right to deny any requested price increase. No price increases are to be billed to any State Agencies prior to written amendment of the contract by the parties.**

**The State will be given full proportionate benefit of any decreases for the term of the contract.**

**G. COST CLARIFICATION**

The State reserves the right to review all aspects of cost for reasonableness and to request clarification of any bid where the cost component shows significant and unsupported deviation from industry standards or in areas where detailed pricing is required.

**H. PERMITS, REGULATIONS, LAWS**

Accept (Initial)	Reject (Initial)	Reject & Provide Alternative (Initial)	NOTES/COMMENTS:

The contract price shall include the cost of all royalties, licenses, permits, and approvals, whether arising from patents, trademarks, copyrights or otherwise, that are in any way involved in the contract. The Vendor shall obtain and pay for all royalties, licenses, and permits, and approvals necessary for the performance of the contract. The Vendor must guarantee that it has the full legal right to the materials, supplies, equipment, software, and other items used to execute this contract.

**1. DEVIATIONS**

The insurance requirements are subject to limited negotiation. Negotiation typically includes, but is not necessarily limited to, the correct type of coverage, necessity for Workers' Compensation, and the type of automobile coverage carried by the Vendor.

**I. NOTICE OF POTENTIAL VENDOR BREACH**

Accept (Initial)	Reject (Initial)	Reject & Provide Alternative (Initial)	NOTES/COMMENTS:

If Vendor breaches the contract or anticipates breaching the contract the Vendor shall immediately give written notice to the State. The notice shall explain the breach or potential breach, and may include a request for a waiver of the breach if so desired. The State may, at its discretion, temporarily or permanently waive the breach. By granting a temporary waiver, the State does not forfeit any rights or remedies to which the State is entitled by law or equity, or pursuant to the provisions of the contract. Failure to give immediate notice, however, may be grounds for denial of any request for a waiver of a breach.

**J. ANTITRUST**

Accept (Initial)	Reject (Initial)	Reject & Provide Alternative (Initial)	NOTES/COMMENTS:

The Vendor hereby assigns to the State any and all claims for overcharges as to goods and/or services provided in connection with this contract resulting from antitrust violations which arise under antitrust laws of the United States and the antitrust laws of the State.

**K. CONFLICT OF INTEREST**

Accept (Initial)	Reject (Initial)	Reject & Provide Alternative (Initial)	NOTES/COMMENTS:

By submitting a bid, bidder certifies that no relationship exists between the bidder and any person or entity which either is, or gives the appearance of, a conflict of interest related to this Request for Bid or project.

Bidder further certifies that bidder will not employ any individual known by bidder to have a conflict of interest nor shall bidder take any action or acquire any interest, either directly or indirectly, which will conflict in any manner or degree with the performance of its contractual obligations hereunder or which creates an actual or appearance of conflict of interest.

If there is an actual or perceived conflict of interest, bidder shall provide with its bid a full disclosure of the facts describing such actual or perceived conflict of interest and a proposed mitigation plan for consideration. The State will then consider such disclosure and proposed mitigation plan and either approve or reject as part of the overall bid evaluation.

**L. ADVERTISING**

Accept (Initial)	Reject (Initial)	Reject & Provide Alternative (Initial)	NOTES/COMMENTS:

The Vendor agrees not to refer to the contract award in advertising in such a manner as to state or imply that the company or its goods and services are endorsed or preferred by the State. Any publicity releases pertaining to the project shall not be issued without prior written approval from the State.

**M. DISASTER RECOVERY/BACK UP PLAN**

Accept (Initial)	Reject (Initial)	Reject & Provide Alternative (Initial)	NOTES/COMMENTS:

The Vendor shall have a disaster recovery and back-up plan, of which a copy should be provided upon request to the State, which includes, but is not limited to equipment, personnel, facilities, and transportation, in order to continue delivery of goods and services as specified under the specifications in the contract in the event of a disaster.

**N. DRUG POLICY**

Accept (Initial)	Reject (Initial)	Reject & Provide Alternative (Initial)	NOTES/COMMENTS:

Vendor certifies it maintains a drug free workplace environment to ensure worker safety and workplace integrity. Vendor agrees to provide a copy of its drug free workplace policy at any time upon request by the State.

**O. WARRANTY**

Accept (Initial)	Reject (Initial)	Reject & Provide Alternative (Initial)	NOTES/COMMENTS:

Despite any clause to the contrary, the Vendor represents and warrants that its services hereunder shall be performed by competent personnel and shall be of professional quality consistent with generally accepted industry standards for the performance of such services and shall comply in all respects with the requirements of this Contract. For any breach of this warranty, the Vendor shall, for a period of ninety (90) days from performance of the service, perform the services again, at no cost to Customer, or if Vendor is unable to perform the services as warranted, Vendor shall reimburse Customer the fees paid to Vendor for the unsatisfactory services. The rights and remedies of the parties under this warranty are in addition to any other rights and remedies of the parties provided by law or equity, including, without limitation actual damages, and, as applicable and awarded under the law, to a prevailing party, reasonable attorneys' fees and costs.

**IV. PAYMENT**

**A. PROHIBITION AGAINST ADVANCE PAYMENT (Statutory)**

Neb. Rev. Stat. §§81-2403 states, “[n]o goods or services shall be deemed to be received by an agency until all such goods or services are completely delivered and finally accepted by the agency.”

**B. TAXES (Statutory)**

The State is not required to pay taxes and assumes no such liability as a result of this solicitation. The Vendor may request a copy of the Nebraska Department of Revenue, Nebraska Resale or Exempt Sale Certificate for Sales Tax Exemption, Form 13 for their records. Any property tax payable on the Vendor's equipment which may be installed in a state-owned facility is the responsibility of the Vendor.

**C. INVOICES**

Invoices for payments must be submitted by the Vendor to the agency requesting the services with sufficient detail to support payment. The terms and conditions included in the Vendor's invoice shall be deemed to be solely for the convenience of the parties. No terms or conditions of any such invoice shall be binding upon the State, and no action by the State, including without limitation the payment of any such invoice in whole or in part, shall be construed as binding or estopping the State with respect to any such term or condition, unless the invoice term or condition has been previously agreed to by the State as an amendment to the contract.

**D. INSPECTION AND APPROVAL**

Accept (Initial)	Reject (Initial)	Reject & Provide Alternative (Initial)	NOTES/COMMENTS:

Final inspection and approval of all work required under the contract shall be performed by the designated State officials.

**E. PAYMENT (Statutory)**

Payment will be made by the responsible agency in compliance with the State of Nebraska Prompt Payment Act (See Neb. Rev. Stat. §81-2403). The State may require the Vendor to accept payment by electronic means such as ACH deposit. In no event shall the State be responsible or liable to pay for any goods and services provided by the Vendor prior to the Effective Date of the contract, and the Vendor hereby waives any claim or cause of action for any such services.

**F. LATE PAYMENT (Statutory)**

The Vendor may charge the responsible agency interest for late payment in compliance with the State of Nebraska Prompt Payment Act (See Neb. Rev. Stat. §§ 81-2401 through 81-2408).

**G. SUBJECT TO FUNDING / FUNDING OUT CLAUSE FOR LOSS OF APPROPRIATIONS (Statutory)**

The State's obligation to pay amounts due on the Contract for fiscal years following the current fiscal year is contingent upon legislative appropriation of funds. Should said funds not be appropriated, the State may terminate the contract with respect to those payments for the fiscal year(s) for which such funds are not appropriated. The State will give the Vendor written notice thirty (30) calendar days prior to the effective date of termination. All obligations of the State to make payments after the termination date will cease. The Vendor shall be entitled to receive just and equitable compensation for any authorized work which has been satisfactorily completed as of the termination date. In no event shall the Vendor be paid for a loss of anticipated profit.

**H. RIGHT TO AUDIT (First Paragraph is Statutory)**

The State shall have the right to audit the Vendor's performance of this contract upon a thirty (30) day written notice. Vendor shall utilize generally accepted accounting principles, and shall maintain the accounting records, and other records and information relevant to the contract (Information) to enable the State to audit the contract. (Neb. Rev. Stat. § 84-304 et seq.) The State may audit and the Vendor shall maintain the information during the term of the contract and for a period of five (5) years after the completion of this contract or until all issues or litigation are resolved, whichever is later. The Vendor shall make the Information available to the State at Vendor's place of business or a location acceptable to both Parties during normal business hours. If this is not practical or the Vendor so elects, the Vendor may provide electronic or paper copies of the Information. The State reserves the right to examine, make copies of, and take notes on any Information relevant to this contract, regardless of the form or the Information, how it is stored, or who possesses the Information. In no circumstances will vendor be required to create



or maintain documents not kept in the ordinary course of vendor's business operations, nor will vendor be required to disclose any information, including but not limited to product cost data, which is confidential or proprietary to vendor.

Accept (Initial)	Reject (Initial)	Reject & Provide Alternative (Initial)	NOTES/COMMENTS:

The Parties shall pay their own costs of the audit unless the audit finds a previously undisclosed overpayment by the State. If a previously undisclosed overpayment exceeds one-half of one percent (.5%) of the total contract billings, or if fraud, material misrepresentations, or non-performance is discovered on the part of the Vendor, the Vendor shall reimburse the State for the total costs of the audit. Overpayments and audit costs owed to the State shall be paid within ninety (90) days of written notice of the claim. The Vendor agrees to correct any material weaknesses or condition found as a result of the audit.

## V. SCOPE OF WORK

The Vendor must provide the following information in response to this solicitation.

### A. SCOPE

It is the intent of this bid invitation to establish a contract to supply **TANDEM AXLE CHASSIS, MINIMUM 60,000 GVWR WITH RDS DUMP BODY & TOW PLOW, HYDRAULICS, PLOW HITCH** per the attached specifications from date of award for a period of two (2) years with the option to renew for an additional three (3) one (1) year periods when mutually agreeable to the vendor and the State. The State reserves the right to extend the period of this contract beyond the end date when mutually agreeable to the vendor and the State.

All items proposed shall be of the latest manufacture in production as of the date of the solicitation and be of proven performance and under standard design complete as regularly advertised and marketed. All necessary materials for satisfactory performance of the supplies shall be incorporated into the **TANDEM AXLE CHASSIS, MINIMUM 60,000 GVWR WITH RDS DUMP BODY & TOW PLOW, HYDRAULICS, PLOW HITCH** whether or not they may be specifically mentioned below.

Complete specifications, manufacturer's current descriptive literature and/or advertising data sheets with cuts or photographs must be included with the bid for the IDENTICAL items proposed. Any information necessary to show compliance with these specifications not given on the manufacturer's descriptive literature and/or advertising data sheets must be supplied in writing on or attached to the bid document. If manufacturer's information necessary to show compliance with these specifications is not attached to the bid document, the Vendor may be required to submit requested information within three (3) business days of a written request. Failure to submit requested descriptive literature or advertising data sheets may be grounds to reject the bid.

**VI. TECHNICAL SPECIFICATIONS**

**A. VENDOR INSTRUCTIONS**

Vendor must respond to each of the following statements. Specifications listed are minimum conditions that must be met in order for a Vendor to qualify for the award.

“YES” response means the Vendor guarantees they can meet this condition.

“NO” response means the Vendor cannot meet this condition and will not be considered.

“NO & PROVIDE ALTERNATIVE” responses should be used only with a narrative response in the NOTES/COMMENTS section explaining in detail any deviation from the Vendor’s ability to meet the condition, and an explanation of how this would be determined to be an acceptable alternative to meeting the condition. Alternatives must be detailed in such a way that allows such deviations to be fully evaluated. The State shall determine at its sole discretion whether or not the Vendor’s alternative is an acceptable alternative.

**B. NON-COMPLIANCE STATEMENT**

YES	NO	NO & PROVIDE ALTERNATIVE	
			1. Read these specifications carefully. Any and all exceptions to these specifications must be written on or attached to solicitation response. Any noncompliance may void your bid. Non-compliance to any single specification can void your bid.
			2. It is the responsibility of Vendors to obtain information and clarifications as provided below. The State is not responsible for any erroneous or incomplete understandings or wrongful interpretations of this solicitation by any Vendor.
			3. No interpretation related to the meaning of solicitation specifications or other pre-bid documents will be made orally to any Vendor by the State. Any solicitation interpretation must be put in writing by the Vendor to the State Purchasing Bureau, E-mail questions to SPB. <a href="mailto:as.materielpurchasing@nebraska.gov">as.materielpurchasing@nebraska.gov</a> by the last day to submit written questions per the Schedule of Events. (Inquiries received after the last day to submit written questions may not be addressed).
<b>NOTES/COMMENTS:</b>			

**C. BASIC SPECIFICATIONS**

YES	NO	NO & PROVIDE ALTERNATIVE	
			1. Shall be no less than 60,000 GROSS VEHICLE WEIGHT RATING.
			2. VIN door tag shall show full GVWR and not reflect calculated bridge capacity rating.
			3. Wheelbase Between 206-220 inches or as required by body installer to meet requirements to mount dump body, wings or other options
			4. Rear axle spacing shall be 54-55 inches.
			5. Cab-to-trunnion shall be minimum 128 to 132 inches as required to meet dump body specifications. This shall be clear; useable space above rails with exception that vertical stack with heat shield may extend up to six (6) into CT area as long as:
			6. Stack with shield is near corner of cab. Right side preferred

YES	NO	NO & PROVIDE ALTERNATIVE	
			7. None of exhaust system in CT area crosses over chassis rails.
			8. Frame resisting bending moment shall equivalent or exceed 2,500,000 inch pounds.
			9. Minimum 18-inch integral front frame extension on truck will be required, front only bumper and fenders to be furnished. Bolt on frame extension is not acceptable
			10. Hood shall be tilt-forward hood/fenders with Service access panels required
			11. Engine shall be equipped with any OEM available extension tube to allow engine oil and automatic transmission fluid to be conveniently checked and filled at service access panel.
			12. Butterfly type of hood for convenient access to engine is acceptable if tilt-forward hood/fenders with service access panel(s) are not available by manufacturer.
			13. Stationary grill to accommodate Department of Transportations' snowplow hitch is required.
			14. All shall be manufacturer's standard or optional equipment.
<b>NOTES/COMMENTS:</b>			

**D. TRANSMISSION**

YES	NO	NO & PROVIDE ALTERNATIVE	
			1. Allison RDS 4000 series automatic transmission with/hold feature in all gears with transmission oil temperature gauge or warning system on or near dash.
			2. Transmission should have Allison Prognostic, load-base shift scheduling and shift energy management features as available
			3. Synthetic oil to be OEM factory fill for transmission.
			4. Manufacture installed stainless steel transmission cooling lines.
			5. Ground speed signal connecting point shall be provided by chassis OEM regardless of transmission installed. Connecting point to be easily accessible by body/hydraulic system installers.
			6. Transmission control module to be located inside cab, if mounting location available thru OEM
<b>NOTES/COMMENTS:</b>			

**E. AXLES AND SPRINGS & SHOCK ABSORBERS**

YES	NO	NO & PROVIDE ALTERNATIVE	
			1. Minimum 20,000 pounds rated capacity axle in front with corresponding multi-leaf springs.
			2. Front axle to be set forward design.

YES	NO	NO & PROVIDE ALTERNATIVE	
			3. Oil filled, front wheel hubs with window required.
			4. Front shock absorbers required, may be dealer installed if not available from manufacturer; indicate what is being bid:_____
			5. Rear air ride suspension assembly shall be Hendrickson PRIMAX with minimum 46,000 pounds rated capacity
			6. Hendrickson PRIMAX heavy duty on/off road suspension required; Rear axles, wheels and tires shall provide minimum of 40,000 pounds capacity to meet bid specification for 60,000 GVWR.
			7. Inter-wheel and inter-axle full locking differentials of manufacturer's recommended brand. Switches shall have indicator lights. Indicate brand:_____
			8. Adequate gear ratios must be suitable for vocational plow truck, Matched with transmission selection. Shall provide road speed of 68 to 70 MPH within manufacturers recommended governed engine RPM design parameters.
			9. Front and rear springs to also meet manufacturer's GVWR requirements.
			10. Manual dump valve for air suspension with indicator light.
			11. Rear axles to have synthetic oil installed.
<b>NOTES/COMMENTS:</b>			

**F. STEERING**

YES	NO	NO & PROVIDE ALTERNATIVE	
			1. Manufacturer's power steering required.
			2. Dual Power steering gearboxes required.
			3. Tilt steering wheel required
<b>NOTES/COMMENTS:</b>			

**G. BRAKES**

YES	NO	NO & PROVIDE ALTERNATIVE	
			1. Service brakes shall be six wheel, full air Disc, ADB (Air Disc Brakes)
			2. Two pads per wheel
			3. Dust shields are required on all axles.
			4. Anti-lock brake system (ABS) to have sensors on all wheels required.
			5. A spring loaded parking brake system designed to automatically apply parking brakes to all four rear wheels when pressure in main air reservoir drops below safe pressure with warning signal is required.
			6. Brake chambers shall be forward facing from axles
			7. Bendix AD-IP dryer or OEM equivalent required, which may be dealer installed in not available by manufacturer. Spin on filter required. OEM brand air dryer must be approved by Nebraska Department of Transportation prior to bid opening Indicate dryer bidding_____

YES	NO	NO & PROVIDE ALTERNATIVE	
			8. Drain valve system for all air tanks must be conveniently operated from side of chassis: system may be dealer installed if not available by manufacturer.
			9. Trailer brakes – truck to be equipped with hand air control valve, break away valve and all necessary lines and connections mounted to the rear of truck chassis required for coupling air brakes on a trailer.
<b>NOTES/COMMENTS:</b>			

**H. ENGINE**

YES	NO	NO & PROVIDE ALTERNATIVE	
			1. Diesel. Minimum 450 HP: actual displacement not less than 12litre, minimum 1650 ft lbs. of torque. Engine shall be certified to meet current EPA emissions standards for the current model year at the time of order. <b>NO OTHER ENGINE WILL BE ACCEPTABLE</b> without written approval by the NDOT Fleet Management prior to bid opening. Please state what engine is to be provided:_____
			2. Engine stated above in Section H-1 shall be certified compliant to meet EPA Standard and Rules for emissions for the current production model year of chassis being provided under this contract.
			3. Vendor shall provide a copy of the “Certificate of Conformity” letter as sent to OEM from United States Environmental Protection Agency office of Transportation and Air Quality. Certificate of Conformity letter should be provided at time of bid opening. Failure to provide Certificate of Conformity letter shall be cause for bid rejection.
			4. The State of NE will not accept a chassis with any engine that is not compliant or if OEM is pay non-compliance penalties to sell said engine/chassis within State of NE.
			5. Muffler to be horizontal with vertical stack on RH side with 90 degree elbowed exhaust outlet that is ABOVE top of cab shield. Elbowed exhaust outlet must be equivalent material and finished as stack and may be dealer installed. Vertical system heat shield required. Horizontal exhaust is acceptable only if required with body and/or wing mounting. If horizontal is used it must have exhaust suppression to prevent damage to pavement during emission system regeneration.
			6. Engine to be equipped with 110 volt AC engine coolant heater; male receptacle with cover for electrical wire for engine heater is to be sturdily mounted.
			7. Cold engine starting system required. KBI Dieselmatic cartridge type or equivalent; cartridge to be furnished with warm engine cut off, which may be dealer installed unless equipped with glow plugs or pre-heater. OEM engine software system to aid cold engine start also acceptable Please state what will be provided:_____
			8. Engine shall have Stainless Steel oil pan, if not available from manufacturer. Then may be dealer installed. Please state what pan supplied._____
			9. Exterior and interior to engine compartment air inlet system for air cleaner. Air cleaner with dual filter elements if available. Please state what will be provided:_____
			10. Front crankshaft provisions required for PTO.
<b>NOTES/COMMENTS:</b>			

**I. FILTERS**

YES	NO	NO & PROVIDE ALTERNATIVE	
			1. Oil filter to be full flow, throw-away type.
			2. Dual element air cleaner if available by manufacturer, Donaldson or equivalent. Bidder should state what is bid: _____
<b>NOTES/COMMENTS:</b>			

**J. COOLING**

YES	NO	NO & PROVIDE ALTERNATIVE	
			1. Manufacturer's heaviest duty cooling capacity radiator to be compatible with front mounted PTO.
			2. Coolant filter if required by engine manufacturer.
			3. Trucks shall have manufacturer's recommended long life antifreeze protection to no less than 34 degrees below zero Fahrenheit.
<b>NOTES/COMMENTS:</b>			

**K. FUEL TANK**

YES	NO	NO & PROVIDE ALTERNATIVE	
			1. Fuel tank to be left side mounted and 100 gallon capacity. Tank extending beyond rear line of cab shall not interfere with wing mount.
			a. Fuel tank to be constructed from aluminum or Stainless Steel if available from OEM. Please state tank material to be provided. _____
			2. Fuel tank to be mounted with Stainless steel mounting straps
			3. Fuel tank shall be regular accessory units AS SHOWN AND LISTED IN TRUCK MANUFACTURER'S DATA BOOKS.
			a. Suction line from tank to pump to be OEM plastic or stratoflex. Stratoflex is preferred.
			4. Fuel/water separator required. Separator shall have engine coolant heater and 12V preheater. Separator to be compatible with bio diesel blends. Davco 384 preferred. Please state what is to be provided. _____
			5. Minimum fourteen (14) inches ground clearance required under fuel tank, DEF tank and supports.
			6. OEM DEF tank shall not interfere with mounting of wing frame, cab shield, etc.
<b>NOTES/COMMENTS:</b>			

**L. WHEELS**

YES	NO	NO & PROVIDE ALTERNATIVE	
			1. Eight on rear of 22.5 by minimum 8.25 inches, ventilated, 10 stud, hub-piloted, steel disc type with 11-1/4 inch diameter bolt circle; identical including color, interchangeable; rear wheels and tires must be spaced to permit use of tire chains.
			2. Front and spare wheels will be 22.5 x 12.25; otherwise meeting specifications.
<b>NOTES/COMMENTS:</b>			

**M. TIRES**

YES	NO	NO & PROVIDE ALTERNATIVE	
			1. Steel belted radials of tubeless type.
			a. Eight, 11R22.5 "H" load range or equivalent metric size on rear.
			2. Tread design to be Michelin XDN2 or equivalent on other brands. Tread to be design for on/off highway traction.
			3. Fronts and spare shall be 425/65R22.5J of Michelin XYA3 or equivalent tread; indicate: _____.
			a. Tires must be Goodyear, Michelin, Bridgestone, Firestone, Continental or General and shall carry said company name.
			b. Indicate brand supplied: _____
<b>NOTES/COMMENTS:</b>			

**N. CAB**

YES	NO	NO & PROVIDE ALTERNATIVE	
			1. Fully enclosed safety type air suspension cab with locks on doors.
			2. National Brand Model 2000 series air seat or OEM equivalent high back seat with air lumbar support on both driver and passenger sides, both with cloth covering and able to adjust forward and backwards on gliders. Please state what seat is to be provided. _____
			a. Seats must be able to provide 6.5 inches of travel
			b. Seat mounted arm rests outboard to be furnished on both driver and passenger seats. If outboard arm rest is available by molded arm rest on door of truck that is acceptable.
			3. Power electric windows on both side windows.
			4. Tinted safety glass in cab.
			5. Front windshield shall include heated defroster grids to aid melting of snow and/or ice buildup during winter operations. Grid to run where wipers changes directions.
			6. Window in bottom, front part of right door if available from manufacturer.
			7. Step or running board on each side of cab.
			8. Interior finish to exclude excessive noise and weather.
			9. Exterior and interior cab grab handles on both sides to facilitate entry into the truck shall be provided.



YES	NO	NO & PROVIDE ALTERNATIVE	
			10. Minimum 107 inches from grade to top of cab is required.
			11. Cab to have minimum 72 inches of shoulder room per specification sheet.
			12. Cab to have minimum 56 inches floor to headliner height.
			13. If manufacturer does not have an air suspension cab available, then a Cabmate by Link Manufacturing Ltd. Is acceptable which may be dealer installed.
NOTES/COMMENTS:			

**O. COLOR**

YES	NO	NO & PROVIDE ALTERNATIVE	
			1. Truck will be highway safety yellow, vendor to provide color chip for approval.
			2. Paint will be base coat/clear coat acrylic, activator-hardened acrylic or polyurethane type.
NOTES/COMMENTS:			

**P. MIRRORS**

YES	NO	NO & PROVIDE ALTERNATIVE	
			1. Rear vision, rectangular Western Type
			<ul style="list-style-type: none"> <li>a. Mirrors to be stainless steel or OEM equivalent electric adjustable heated type with tinted or non-glare glass.</li> <li>b. Indicate type supplied _____</li> </ul>
			2. Size 16 inch by 7 inch or approximately 110 square inches.
			3. Mounted on right and left doors of cab, extendable to maximum legal width.
			4. 8" convex mirror or equivalent size to be mounted below the 16" x 7" mirror on each side. Convex mirror not to overlap main mirror. Convex mirror to be heated type.
NOTES/COMMENTS:			

**Q. LIGHTS**

YES	NO	NO & PROVIDE ALTERNATIVE	
			<p>1. Halogen headlights with high and low beam. Parking, dome, double tail and stop lights, front and rear directional turn signal lights are to be LED if available from OEM. OEM supplied LED headlights would also be acceptable</p> <ul style="list-style-type: none"> <li>a. Please state what will be provided: _____</li> </ul>

YES	NO	NO & PROVIDE ALTERNATIVE	
			2. LED double tail and stop lights. Stop, turn and tail may be deleted if not ordered as cab chassis. S/T/T lights required with dump body.
			3. Wiring harness with connector for auxiliary lighting is required if available from manufacturer. Auxiliary snowplow lighting is required with dump body installation. Circuit to be battery powered if available.
<b>NOTES/COMMENTS:</b>			

**R. CONTROLS & INSTRUMENTS**

YES	NO	NO & PROVIDE ALTERNATIVE	
			1. Key locking ignition switch; head, parking and dome light switch; traffic hazard switch; headlight beam control; electronic engine/PTO controls; speedometer.
			a. Electronic engine/PTO control will act as engine RPM idle control when truck is stationary and act as "cruise or speed" control when truck is in motion.
			2. Voltmeter, oil pressure gauge; fuel gauge; engine temperature gauge; air pressure gauge.
			3. High beam indicator lights, flashing turn-indicator lights, three sets of keys required per vehicle. Self-canceling turn signal switch on steering column.
			4. Engine hour meter, tachometer and vacuum restriction gauge for air cleaner are required, which shall be dash mounted. If manufacturer does not offer a vacuum restriction gauge on dash then a Filter Minder brand of gauge that is dash mounted is acceptable, which may be dealer installed.
			5. Control for inter-wheel inter-axle locking differentials shall have dash mounted indicator light.
			6. Rearview camera system is required and may be installed by dump body installer. Camera system to be tied into spreader control monitor. It is to be active by transmission being put in reverse or operator to view at any time. one camera mounted to provide clear view of area behind truck with dump body and spreader installed. Please state what system is to be provided:
			a. Camera System monitor shall have minimum of 3 camera input to allow additional cameras to be installed by NDOT at later date.
			7. Rear view camera should have minimum 170 degree field of view. Camera with heated lens would also be preferred. Camera to be mounted in the area above pintle plate that will provide view under tailgate spreader when installed.
<b>NOTES/COMMENTS:</b>			

**S. WINDSHIELD WIPERS**

YES	NO	NO & PROVIDE ALTERNATIVE	
			1. Heaviest duty dual electrical wipers available with intermittent capability.
			2. Heated wiper blade capability , may be dealer installed.
			3. Dual electric windshield washers. Washer nozzles to be integrated into wiper arms.
<b>NOTES/COMMENTS:</b>			

**T. ELECTRICAL**

YES	NO	NO & PROVIDE ALTERNATIVE	
			1. System to be 12 volts.
			2. Manufacturer's recommended batteries for diesel engine quoted; but minimum of three (3) batteries and 2700 CCA; indicate: _____.
			3. Alternator shall be a Delco 28 SI or Bosch equivalent with minimum 160 amperes rating.
			4. Positive and negative jump start studs required. Must be easily accessible at side of chassis. Use of frame or frame hardware is not acceptable for negative stud.
			5. Trailer lighting harness and 7 pin ATA plug required at end of frame for trailer hookup.
			6. Chassis shall have easily accessible battery disconnect switch near the battery box or other OEM mounting location that is easily accessible for operators. Please state location of switch: _____.
<b>NOTES/COMMENTS:</b>			

**U. GENERAL**

YES	NO	NO & PROVIDE ALTERNATIVE	
			1. Dual electric horns; two padded sun visors. Manufacturer's standard air horn(s) shall be provided.
			2. Truck manufacturer's recommended outside air intake heater with defroster to entire windshield, Two 12v power outlet on dash W/USB .
			3. Manufacturer's standard manually controlled air conditioning; seat belts for right and left seats with retractors, lap/shoulder type.
			4. Factory installed AM/FM radio, preferable with antenna mounted on cowl instead of top of cab.
<b>NOTES/COMMENTS:</b>			

**V. RADIO FREQUENCY SHIELDING-CAUTION!!!!**

YES	NO	NO & PROVIDE ALTERNATIVE	
			1. The UNIT and/or installed components and equipment shall be compatible with use of NDOT mobile and/or two-way communication devices. Main communication radio operates in low band range of 47MHz to 48MHz, but all frequencies apply including low band, high band, UHF, and VHF.
			2. The UNIT and/or installed components and equipment shall be manufactured to meet all current SAE and/or ISO Standards applicable and/or relevant to electromagnetic Compatibility.
			3. NDOT will conduct testing of radio/two-way when installed in chassis. NDOT will notify vendor if normal operational parameters are not met due to degradation of signals caused by electromagnetic emissions from chassis or installed components and equipment. Vendor shall be required to work with NDOT personnel to reduce interference level to a point

YES	NO	NO & PROVIDE ALTERNATIVE	
			acceptable to NDOT normal radio operating parameters. Vendor shall have 30 days to resolve RFI issue.
			4. Vendor and/or manufacturer will be responsible for any and all cost to replace and/or modify any parts found to cause radio frequency interference. If NDOT and vendor cannot resolve source of RFI the unit will be sent to an independent accredited lab for testing to ensure SAE and/or ISO Standards compliance. Testing shall be done to SAE and/or ISO Standards which are current at date of bid. Should the loader and/or installed components and equipment fail testing at the accredited lab, the vendor shall be responsible for all cost incurred for testing.
			5. If after testing by NDOT and/or accredited lab, the vendor is unable or unwilling to incur the cost and correct the RFI issue to the satisfaction of NDOT, all orders and corresponding contract will be canceled.
<b>NOTES/COMMENTS:</b>			

**W. FACTORY INSPECTION**

YES	NO	NO & PROVIDE ALTERNATIVE	
			1. The first truck chassis manufactured shall be made available for inspection by NDOT personnel at factory.
			2. Vendor representative(s) shall accompany NDOT personnel during the inspection.
			a. Vendor shall be responsible to have body and hitch representatives in attendance at inspection to resolve any possible problems.
			3. Transportation, meals and lodging cost for NDOT representative(s) to perform required inspection shall be at the vendor's expense. Vendor/manufacturer must provide space in building to do inspection. NDOT will send minimum of two (2) people and possibly a third person to factory pilot inspection.
<b>NOTES/COMMENTS:</b>			

**X. WARRANTY**

YES	NO	NO & PROVIDE ALTERNATIVE	
			1. The manufacturer's regular warranty certificate will be required with each unit delivered and the warranty shall apply, in all cases, with the following exceptions.
			2. Because of the installation or attachment of auxiliary or supplementary equipment by the Department or sub-vendor, the effective date of warranty will be after field assignment. As each unit is assigned for service the Department will maintain a record of serial number and assignment date.
			3. Manufacturer's written warranty including engine, transmission and differential must accompany delivered units.
			4. Full, manufacturer's warranty coverage will be required for the stated warranty period, beginning at assignment date, in addition to the time between delivery and field assignment.
			5. Prior to the awarding of, or entering into any agreement or contract, it shall be the responsibility of the manufacturer and/or the successful bidder to

YES	NO	NO & PROVIDE ALTERNATIVE	
			warrant to the State of Nebraska, in writing, that it has factory authorized dealers in the State of Nebraska who will provide warranty/service and repair work without undue delay.
			6. Provide any information on towing available and what is covered.
			7. It is understood that the bidder accepts the above warranty requirements when offering a bid.
<b>NOTES/COMMENTS:</b>			

**Y. SERVICE**

YES	NO	NO & PROVIDE ALTERNATIVE	
			1. Manufacturer's standard warranty, completed pre-delivery inspection certificate, Manufacturer's Statement of Origin and line sheet will be required at time each unit is delivered.
			2. Service policy shall be honored by all of the manufacturer's authorized dealers in the State of Nebraska.
			3. Dealer's decals, stickers, or other signs shall not be put on units; manufacturer's nameplates, stampings and other similar signs are acceptable.
<b>NOTES/COMMENTS:</b>			

**Z. MANUALS**

YES	NO	NO & PROVIDE ALTERNATIVE	
			1. Operator's manual should accompany each unit when delivered.
			2. Equipment shop repair manual or CD ROM. If available online the State of Nebraska must be able to access it free of charge for fifteen (15) years.
			3. Engine shop repair manual or CD ROM. If available online the State of Nebraska must be able to access it free of charge for fifteen (15) years.
			4. Equipment parts manual or CD ROM. If available online the State of Nebraska must be able to access it free of charge for fifteen (15) years.
			5. Engine parts manual or CD ROM. If available online the State of Nebraska must be able to access it free of charge for fifteen (15) years.
			6. All manuals must be furnished prior to payment and delivered to Fleet Management, Equipment Data Coordinator. Failure to deliver all manuals that are ordered may result in non-payment of ten percent of purchase order total until all manuals are delivered.
<b>NOTES/COMMENTS:</b>			

**AA. SPECIFICATION FORMS**

YES	NO	NO & PROVIDE ALTERNATIVE	
			1. Specification form(s) will be supplied by Department of Transportation to the awarded vendor after a purchase order has been issued. The awarded vendor will be required to complete specification form to the fullest extent possible for each unit and must accompany each unit when delivered.
			2. If vendor does not properly complete form for each unit, a sum of \$250.00 per unit will be deducted from purchase order total.
NOTES/COMMENTS:			

**BB. DELIVERY & PAYMENT**

YES	NO	NO & PROVIDE ALTERNATIVE	
			1. After vendor completes pre-delivery service, vendor shall deliver the unit to the Nebraska Department of Transportation, 5001 South 14 <sup>th</sup> Street, Lincoln, Nebraska, between 9:00 AM and 3:00 PM daily except Saturday, Sunday and holidays.
			2. Each unit shall be delivered with not less than twenty gallons of fuel in tank.
			3. Vendor must notify Fleet Management a minimum of 24 hours prior to delivery to Nebraska Department of Transportation on workday basis at (402) 479-4319 or (402) 479-4323.
			4. Manufacturer's Statement of Origin and other pertinent purchasing documents must accompany invoice.
			5. Pricing and delivery for completed chassis with dump body are to be FOB 5001 South 14 <sup>th</sup> St. Lincoln NE
			6. Delivery of completed chassis with dump body is desired within 200 days of receipt of order by vendor. Delivery time beyond 200 days may result in bid not being considered. Please state delivery days here and on Invitation to Bid Contract form. Delivery days _____
NOTES/COMMENTS:			

**CC. INSURANCE**

YES	NO	NO & PROVIDE ALTERNATIVE	
			1. The vendor will be required to fully insure all chassis, for all perils, until delivery to and accepted by the Department of Transportation, Fleet Management, 5001 South 14 <sup>th</sup> Street, Lincoln, Nebraska.
			2. Proof of insurance must be furnished within five days after notification of award to State Purchasing Bureau at address on the invitation to bid.
			3. If delivery is earlier than indicated by bidder on invitation to bid, vendor must furnish insurance from actual delivery date to date specified on invitation to bid.
			4. The State of Nebraska assumes, ownership at time of actual delivery at 5001 South 14 <sup>th</sup> Street, Lincoln, Nebraska and acceptance of complete unit.
NOTES/COMMENTS:			

**DD. BODY**

YES	NO	NO & PROVIDE ALTERNATIVE	
			1. Body Shall be Stainless steel Monroe RDS Model and meet Following Specifications.
			2. Unless stated otherwise, all steel to be 201 or 304 Stainless Steel with minimum 105,000 psi tensile strength, 100% continuous weld construction, no skip welding.
			3. Length of 14 feet required. Minimum CA of 133 inches.
			4. Top inside width shall be 87 inches with total outside width being 96 inches.
			5. Side height of 42 inches minimum required. May be sloped front to rear to match tailgate height.
			6. Tailgate height of 42 inched minimum.
			7. Minimum capacity of 10.43 cubic yards.
			8. The longsills shall be fabricated from ¼" stainless steel, 14" deep.
			a. Sections of 4" x 5.4# channel are welded every two (2) feet, the length of the spreader at the base of the longsills, where the longsills are then boxed in with ¼" stainless steel
			b. Then there shall be 3/16" x 3" x 3" structural angle welding every 12" the full length of the conveyor at the top of the longsills.
			9. The unit shall have a ¼" stainless steel replaceable floor with 3/16" removable chain guards.
			10. The sides must be of a radius design for strength and to allow free flow of granular material to the conveyor
			11. The boxed top rail shall be a minimum of 3/16 inch formed channel.
			12. The front shall be sloped to accommodate a headlift cylinder with partial doghouse and conform with the radius of the body and shall be 100% welded inside and outside.
			13. Side supports shall be added and shall have 3/16" x 4" tube. 4" tube extending through long members with 3/16" boxed section welded 100% from top rail of the body tube, 3/16" stainless steel construction.
			14. Top rail of RDS body shall be compatible for tarp installation. Top rail may be sloped front to back.
			15. Top rail to have access hole for safety strobe system.
			16. NDOT will require that the head sheet have a NDOT mounting bracket bolted to both left and right side. NDOT will provide samples of required brackets to the winning bidder to have built to specifications.
			17. Box shall have the Whelen heated taillight housing part number 11-487697-1ss or equivalent with approval from NDOT Fleet management before bid opening. Please state what is being bid.
<b>NOTES/COMMENTS:</b>			

**EE. TAILGATE**

YES	NO	NO & PROVIDE ALTERNATIVE	
			1. Tailgate shall be compatible for use with roll tarp. Shall be manufactured from 3/16 inch stainless steel on the bottom and ¼ inch formed channels on the sides.
			2. Tailgate shall be double acting with squared perimeter, having two horizontal braces od 10 gauge material lull width of the tailgate
			3. Material door shall be extended 16" into the interior of the body to prevent material from escaping through the partially opened door over the conveyer.

			4. Opening shall be 21" in width by 8-1/2" in height. Tailgate shall have 1x4" bar stock tailgate hardware with harden pins.
			5. Air tailgate latches shall be 1" flame cut, with each latch being adjustable with threaded clevis and keeper pins. Latch shall be an over center type.
			6. Tailgate to be air operated with in cab switch to control tailgate release. Solenoid activated air tailgate, solenoid air vent shall be stainless steel.
<b>NOTES/COMMENTS:</b>			

**FF. CONVEYOR ASSEMBLY**

YES	NO	NO & PROVIDE ALTERNATIVE	
			1. The body conveyor shall be 34 inches in width and shall have 28,000 pound tensile strength per strand pintle chain, with 1-1/2 inch x 1/2" inch bar flights on 4-1/2 inch centers. Pintle chain shall 30.50 center to center on.
			a. Conveyor to be driven by two high torque/variable speed 6:1 spur gearboxes and two hydraulic motor with ground speed sensor capability. Preferably gearboxes are to be retained by a clevis type torque arm mount.
			b. There shall be 8 tooth sprockets keyed to the 2 inch drive and idler shafts.
			2. Conveyor drive shaft shall be heavy duty, dust sealed self-aligning four bolt flange bearings.
			3. There shall be a heavy duty idler assembly that will provide adjustment for proper conveyor chain tension by use of slide_ rail style adjusters
<b>NOTES/COMMENTS:</b>			

**GG. FRONT CROSS CONVEYOR**

YES	NO	NO & PROVIDE ALTERNATIVE	
			1. The unit shall have a front cross conveyor with spinner.
			2. The conveyor shall be minimum 19 inches wide and shall utilize a two-ply rubber belt
			3. The belt shall be heavy duty, with top cover measuring 3/16 inch and the bottom ply measuring 1/16 inch. Total thickness being 3/8 inch.
			4. The belt shall have a working tension of 150 pounds per inch of width.
			5. The conveyor shall be direct driven by a 5 inch roller on one end of conveyor, the main idler roller shall also be a 5 inch diameter. flange bearings.
			6. There shall also be two 3 inch idler rollers for belt return and four idler 2 bolt flange bearings.
			7. The conveyor will have five 1-1/4 inch bearing with four bolt flanges and three 1-1/4 inch bearings with cast housings that are adjustable in a rail type frame.
<b>NOTES/COMMENTS:</b>			



**HH. SPINNER ASSEMBLY**

YES	NO	NO & PROVIDE ALTERNATIVE	
			1. The spinner assembly shall be manufactured from 3/16 inch stainless steel and shall have a material deflector shield integral to the body.
			2. The spinner motor shall be high torque/low speed mounted directly to the spinner disc with a cast hub.
			3. The spinner disc shall be 20 inch in diameter and manufactured of polyurethane with six molded-in fins
<b>NOTES/COMMENTS:</b>			

**II. STATIONARY CAB SHIELD**

YES	NO	NO & PROVIDE ALTERNATIVE	
			1. Cab shield shall cover rear, one half of cab and be constructed of 201 stainless steel.
			a. Be reasonably close to top of cab.
			b. Allow visibility from rear cab window.
			c. Shall be the same width as widest part of cab above doors.
			d. The cab shield uprights shall be a formed channel using ¼ inch 201 stainless steel with approximately a 2 ¾ flange and eight inch width. Formed channels to be approved by Nebraska Department of Transportation prior to use and installation.
			e. Each upright shall be bolted with minimum of five each of 5/8 inch grad 8 bolts to chassis rail. Welding and gusseting of right hand upright to wing sub-frame is acceptable.
			f. Upright flanges shall face away from center of chassis.
			g. Uprights shall be further stiffened to rail with 8 inch length of 3/8 inch by 3 inches by 3 inches angle irons placed on top of rails and properly welded to uprights. This angle iron may also act as the bottom support for the hydraulic reservoir. This angle iron shall not be welded to frame rails but must rest squarely on chassis rail.
			h. All seams to be continuous, skip weld will not be accepted.
			2. Top cross member shall be adequately welded to uprights and gusseted with two (2) ¼ inch steel plates of 6 inches by 6 inches by about 8-1/2 inches dimensions at rear part of assembly.
			3. Cab shield shall be welded to uprights and top cross member. Cab shield material shall be minimum 10 gauge thickness.
			a. Reinforced and weld to cross member with two 3 inches by 1-3/8 (4.1) channel irons, which extend the full length of cab shield and align with eight inch channel uprights.
			b. Adequately gusseted from 3 inch x 4.1 channel iron to eight inch channel iron.
			c. Welded to 4.1 channel iron with flanges downward.
			d. Meet all OSHA standards.
			e. Have provisions that do not allow ponding of water. (No Drain Holes).
			4. Flame cut openings in cab shield shall allow vision thru rear window area.
			a. Shield shall be placed to allow ample visibility from rear window.
			b. Outer skirts of cab shield shall extend a minimum of six (6) inches below rear cab window.
			c. A two-inch angle iron will be welded to uprights near top of hydraulic reservoir.
			d. An approximate three (3) inch opening from top of reservoir to angle iron is required to allow hand access.

			5. Adequately-sized openings with rounded corners will be necessary in eight (8) inch channel uprights for filler tube, temperature/sight gauge and other hydraulic components to be mounted on left side of truck. Openings will be done in a professional manner with straight sides with minimum one-half inch radius corners.
			6. Welding to be continuous on both sides of gussets, channels and cross members.
			7. Three (3) strobe light mounting brackets are required to be installed on each unit. Bracket sample will be provided by NDOT to provide successful bidder with proper bolt pattern for NDOT lighting.
			8. One (1) bracket shall be center mounted on top of cab shield. The other two (2) brackets shall be mounted on top of cab shield, one on each side. Placement of brackets shall be such that auxiliary plow lights will not impair visibility of strobe lights.
<b>NOTES/COMMENTS:</b>			

**JJ. MUDFLAPS**

YES	NO	NO & PROVIDE ALTERNATIVE	
			1. Mud flaps mounted behind and in front of tandems as per Nebraska Statutes.
			a. Front mud flap bracket can either be truck frame or body mounted. Must provide for anti-sail and not interfere with any of the truck components.
			b. Rear mud flaps shall be attached to body with adequately-sized chain links.
			2. Dealer nameplate(s) and other dealer sign(s) on rear mud flaps shall not face to rear of truck.
<b>NOTES/COMMENTS:</b>			

**KK. HOIST**

YES	NO	NO & PROVIDE ALTERNATIVE	
			1. Mailhot single, front-mount, telescopic, cylinder, Inverted trunnion mounted. It shall be dual acting power up and power down.
			2. All components of this cylinder with the exception of the seal kit shall be processed through a liquid salt bath nitriding treatment to enhance the surface hardness and corrosion resistance.
			3. National Truck Equipment Association minimum Class 90 rating required.
			4. Minimum dump angle approximately 45 degrees.
			5. Cylinder shall have length of stroke as required by body manufacturer and shall be offered as standard production by manufacturer.
			6. Hoist cannot protrude above front side of box or front bow cap of tarp. To be Roll Tarp compatible.
<b>NOTES/COMMENTS:</b>			

**LL. HYDRAULIC SYSTEM**

YES	NO	NO & PROVIDE ALTERNATIVE	
			1. The truck hydraulic pump shall be directly driven via a Spicer Number 1350 driveshaft connected to an OEM supplied PTO drive flange mounted on the engine front crankshaft dampener.
			2. Driveshaft shall pass under or through the engine radiator; under if possible.
			A. Drive flange attachment bolts and the hydraulic pump shaft set screw shall be safety wired.
			B. The driveline grease zerks shall be easily serviced.
			C. A heavy duty PTO shield is required from pump to front of chassis, which shall be attached to snow plow hitch or be a part thereof.
			3. The truck hydraulic pump shall be a minimum 8.75 cubic inch (145cc) variable displacement load-sense designed for continuous operation. The pump shall be a Parker P2145 or equivalent. Indicate brand & model supplying: _____
			A. The hydraulic pump shall be capable of producing a nominal 60 GPM flow at 1,800 engine RPM with a minimum 3,000 PSI operation pressure.
			4. Hydraulic system pressure will be set to operate at 2500 p.s.i.
			5. Hydraulic pump outlet port shall have an electronically operated valve to be operated by low hydraulic oil sensor. Valve will close when hydraulic oil is low.
			6. ½ inch hydraulic hoses from hydraulic stack valve to the front of the snow plow hitch for raise-lower and plow angle functions.
			A. Hoses to be rigidly mounted with ISO 16028 flat face interchange couplings. Couplers (one male and one female) placed so as not to interfere with plow hitch or plow function.
			1. Example of couplers: Faster FFH0812NPT/Faster FFH0812NPTM (FPQ Premier) Parker FEM-501-8FP-ZP/Parker FEM-502-8FP-ZJ (XTR) Stucchi Part #2317188/2317189 (Z plated).
			2. Couplers to meet ISO 9227 standards to a minimum of 400 hours salt spray test.
			B. Hoses with one of the above listed couplers (one male and one female) shall be installed to plow cylinder.
			C. Plow up-down couplers to be mounted on plow hitch on passenger's side of truck. Plow angle couplers to be mounted on plow hitch on driver's side of truck.
			D. Plow angle circuit will have pressure relief valve. To be mounted inside frame rail near hitch.
			E. Only steel wire braided hoses are acceptable.
			F. Hydraulic oil to be multi-purpose, all season type. Please state ISO grade furnished: _____
			7. The hydraulic control valve(s) to be a stack valve type load independent proportional valve which is closed center, load sensing and pressure compensated to control three (3) functions simultaneously. A valve assembly utilizing a modular manifold with individual valve sections would also be acceptable. The control center console shall be floor mounted.
			A. The valve is to be controlled by electrical proportional actuation.
			B. Each valve section shall be equipped with adjustable trim control, flow control, spool stroke limiters or other means to control oil flow for each function independently.
			C. Valve is to be arranged as follows:
			1. Closed center inlet with relief.
			2. Hoist = 4 way, 26 gpm, 500 psi down port relief
			3. Plow lift = 4 way, 10 gpm
			4. Plow angle = 4 way, 10 gpm
			5. Wing toe = 4 way, 10 gpm, 500 psi down port relief (if required).

YES	NO	NO & PROVIDE ALTERNATIVE	
			6. Wing heel = 4 way, 10 gpm, 500 psi down port relief, 2000 psi up port relief (if required).
			7. Auger = 4 way, 17 gpm motor spool or cartridge valve.
			8. Spinner = 3 way, 10 gpm motor spool or cartridge valve.
			9. Prewet = 3 way, 6 gpm motor spool or cartridge valve.
			10. Tow plow steering = 4 way 10gpm
			11. Tow plow raise/lower = 3 way 10 gpm
			12. Trailer spreader = 4 way 15 gpm motor spool
			13. Trailer spinner = 1 way 10 gpm motor spool
			14. Trailer pre wet = 4 way 6 gpm motor spool
			15. Endcover
			D. Hydraulic control valve to be mounted behind cab a weatherproof enclosure with hydraulic oil tank. Location and hose routing to be reviewed during pilot inspection.
			E. Pressure and return hoses for anti-ice, pre-wet, spreader auger and spinner shall be routed from stack valve to rear of dump at lower horizontal rib ½" flat face couplers as previously stated shall be used. Function shall have individual pressure and return couplers. Two function/four couplers per side.
			8. The control center shall be a full proportional control of all hydraulic functions, spreader control functions with one single joystick or multiple joysticks to be located in the integral armrest. The control center with integral armrest shall be floor mounted.
			A. A drawing of proposed design must be submitted with bid packet. Drawings to include switch locations.
			B. Control of hydraulic functions with a fully proportional joystick(s) is to be located in the armrest. The armrest should be height adjustable and swing to left and right
			C. Joystick operation is described as follows:
			1. Shall operate proportionally and shall have the ability to run three (3) functions simultaneously.
			2. Hoist function: with operator activated safety lock.
			3. Plow function: lift-forward/backwards axis
			4. Plow angle-left /right axis
			5. Wing function- dual axis with operator activated safety lock.
			6. Wing lift- forward/backward axis
			7. Wing heel- left/right axis
			8. Benching Wing rear slide forward/backward axis.
			D. Spreader control, harness and wiring to back of truck will be set up for granular pre-wet, anti-ice, and total liquid use even if functions are not utilized.
			E. Spreader control System shall be Force America brand, Model 6100 or Certified Power brand, Model XDS. Would also be accepted. State System to be provided:
			1. It shall be capable of controlling the application rates of granular, with pre-wetting agents, and/or anti-icing agents simultaneously or independently, regardless of vehicle speed.
			2. Hydraulic system must be capable of operating chassis spreader and trailer spreader simultaneously with working either truck blade raise or tow plow blade raise
			3. Control must be GPS compatible. The spreader controller shall provide a standard output of real-time streaming data including but not limited to: Ground speed, surface and air temperature, material selected, material application rate, lane(s) material being applied to and pre-wet rate.
			a. The output shall be in standard format such as ASCII through a standard 9 pin, USB or other connector that

YES	NO	NO & PROVIDE ALTERNATIVE	
			meet NDOT approval.
			b. The data shall be formatted so that 3 <sup>rd</sup> party devices can read informational data in real time. All hardware, software and information necessary for 3 <sup>rd</sup> party device to read the data output shall be if requested at no additional charge to NDOT.
			4. It must be possible to reprogram the controller by upgrading the software.
			5. The control shall be installed onto the control console, mounted onto the dash or other pre-approved area. Installation shall position the control so it is easy for the operator to see and reach.
			6. Anti-ice feature shall include a 3-lane selective lane switch box mounted in, under or near the console or through the soft keys of controller. Box shall have four (4) switches, the first to allow selection of either anti-ice or granular system, the remaining three (3) shall be lane selections switches, left, center and right.
			a. Anti-ice system shall adjust pump output to maintain selected rate as lanes are activated or deactivated.
			b. Anti-ice system to close valves to prevent gravitational flow of liquid when truck is stopped or 'pass' button is pushed.
			c. Anti-ice system to provide an audio alarm for insufficient application of liquid. Display shall show actual rate being applied.
			d. An electronic display capable of being reset to indicate gallons remaining in tank or gallons used since reset.
			7. Control shall allow up to a minimum of ten different preprogrammed application rates plus a manual override feature. It shall be capable of four granular products and tow liquid products. A blast feature shall be incorporated.
			8. Controller blast button shall immediately cause full hydraulic flow to the auger section, causing maximum spreader material output. The blast system shall be equipped with a timer. Blast feature shall also work with Anti-Ice function.
			9. Controller shall default to 'pass or stand by' upon startup of truck even if console master switch is 'on'. This will eliminate material being spread when truck starts to move in year or is started in shop bay.
			10. A data lock key shall be part of the controller to prevent data or programs from being changed or deleted without key access. Password program also acceptable.
			11. A key shall be provided for each controller.
			12. Granular rates may be selectively displayed in pounds-per-lane-mile or kilograms-per-kilometer. Liquid pre-wet rates may be selectively displayed in gallons-per-ton or liters-per-metric ton.
			13. Controller shall have a non-volatile memory to store all program and data when it is disconnected from a power source.
			14. A LCD color display, minimum of seven (7) inches diagonal shall provide the operator with instant access to:
			a. Total distance.
			b. Total granular applied.
			c. Total liquid applied.
			d. Vehicle speed.
			e. Distance traveled.

YES	NO	NO & PROVIDE ALTERNATIVE	
			f. Low oil indicator.
			g. Body up indicator.
			15. All spreader control harnessing shall meet ISO IP68 and NEMA 6 standards. The connectors should be die cast E-coated, and be designed to have NO corrosion after 500 hours in a 35C salt spray. Each should have three sealing points (1) the lock ring itself, (2) a raised portion of the molded plastic around each pin, and (3) a Viton O-ring that seals the whole connector. Wiring to be equivalent to Daniel Woodhead, Brad Harrison electrical connectors and wiring.
			9. Switch panel to be Wired-Rite System Inc., Touchguard or Force America brands. Switches will have built-in bus bar connecting, silk screen backlit function indicators and magnetic automatic reset internal circuit breakers. Wiring shall include adequate slack to allow entire panel to be easily removed for service or replacement
			A. Main 12 volt battery feed into truck cab control box shall be protected by an 80 amp manual resetting waterproof circuit breaker (Wired Rite DB-80R or equivalent) installed close to the battery enclosure installed on the truck cab fire wall or within battery cover enclosure.
			B. The power feed line to the 80 amp breaker shall be a minimum of 4-gauge fine strand copper.
			C. The positive/negative wires into the cab from the breaker and truck frame ground shall be 4-gauge.
			D. Switch circuits will be either a battery or ignition type. Battery circuits shall be always hot. Ignition circuits will receive power through a Bosch model 0332002150 75 amp relay when the ignition switch is in both the accessory or run positions.
			E. The switches and lamps shall be labeled and function as follows: Right to left.
			1. Plow/Truck Lights, (if OEM chassis supplied this is to be changed to an auxiliary switch SPST off/on) Battery DPDT, 2 position, ON/ON
			2. Cab/Hood Plow Lights Battery DPDT, 2 position ON/ON
			3. Amber /Blue strobe light Switch Ignition SPST, ON/OFF
			4. Clear /White strobe light Switch Ignition SPST, ON/OFF
			5. Wing light Switch Battery SPST, ON/OFF
			6. Spreader switch Battery SPST, ON/OFF
			7. Auxiliary switch Ignition SPST, ON/OFF
			8. Auxiliary Switch Ignition SPST ON/OFF
			9. Winter/Summer DPDT, 2 position, ON/ON
			F. Trailer warning lights switches connected to six pin trailer plug 1. Rear beacon/strobe lights Battery SPST ON/OFF
			2. Wing light battery SPST ON/OFF
			G. A guarded/protected switch is also required to allow temporary

YES	NO	NO & PROVIDE ALTERNATIVE	
			over ride of low hydraulic oil shut down solenoid. This will allow operator to possibly operate any function to allow unit to be moved off roadway.
			<b>H.</b> The body up indicator lamp shall function as a dump body height warning system. In both the winter and summer mode, it shall illuminate whenever the body is raised.
			1. In addition, in the winter mode, working through an adjustable angle mercury switch, this system shall also include a flasher and audible alarm that will engage when the body attains the pre-set height adjustment of the mercury switch.
			2. Alarm must be loud enough to be heard over any truck noise.
			<b>I.</b> The Winter/Summer switch shall control power to the dump body height warning circuit. In the winter mode it will power the height warning feature of the dump body up lamp circuit causing it to function as designed. In the summer mode, it will not allow power to the dump height warning circuit.
			<b>J.</b> Switch panel to be located on the armrest portion of the control console and not interfere with the operation of the joystick.
			<b>10.</b> Hydraulic reservoir to be minimum 50 gallon oil capacity with five gallon expansion space for total 55 gallons.
			<b>A.</b> Reservoir to be sturdily mounted, and complete with suction strainer return filter and adequate shut-off valves for servicing.
			<b>B.</b> Return filter shall have a 10 micron rating. Filter shall be interchangeable with such filters as Donaldson P550388, Wix 51759, or Baldwin TB287-10. Please state filter to be provided:
			<b>C.</b> Suction strainer shall be 100 mesh with 5 PSI relief valve.
			<b>D.</b> A gate-type or ball valve shut-off valve, of at least the size of the suction line, is required between the reservoir and the suction line itself.
			<b>11.</b> Reservoir tank shall be mounted between the cab and body within the confines of 12 inch channel upright for cab shield.
			<b>A.</b> The 7 gauge steel reservoir will be 12 inches wide.
			<b>B.</b> The approximate height will be 32 inches and approximate width of 33.5 inches.
			1. The reservoir must be of such height to allow visibility through rear cab window and to accommodate other chassis/body requirements.
			<b>C.</b> Reservoir will have a 45 to 70 degree filler pipe. Filler pipe will extend a minimum of three (3) inches through upright.
			1. Filler neck shall be removable from top of tank.
			<b>D.</b> A sight gauge with Fahrenheit temperature scale for checking proper oil level shall be furnished.
			1. Sight gauge location shall be on same side of reservoir as filler tube.
			<b>E.</b> A hydraulic oil low level alarm or indicator light is required.
			1. Alarm or light to be mounted in the cab.
			<b>12.</b> Bottom rear of tank on each side will have flat steel plates welded to back of tank with holes for bolting to upright flange.
			<b>A.</b> Upper part of tank will have ¼-inch x 6-inch flat plate welded to center of tank with holes for bolting to angle iron cross member between uprights. Bolts to be Grade 8.
			<b>B.</b> Tank shall be mounted so as to have adequate clearance from chassis components and so that it can be conveniently removed without moving the twelve inch uprights that secure the tank.
			<b>13.</b> The filter will be mounted on the same side of tank as filler tube.
			<b>A.</b> Reservoir will have a 1-inch magnetic drain plug and baffle(s) as needed.
			<b>B.</b> All components of hydraulic system shall be of size that will not

YES	NO	NO & PROVIDE ALTERNATIVE	
			restrict flow and withstand a minimum working pressure of 2,500 PSI.
			<b>14.</b> Vendor will minimize the number of critical rub points for hydraulic hoses, where critical rub points exist; they shall be wrapped with spiral metal or adequate rubber wrap.
			<b>15.</b> System shall permit the dump body to be raised or lowered while vehicle is traveling at highway speeds up to 35 MPH as well as when vehicle is not moving.
			<b>A.</b> Partially or fully raised box shall not creep up or down when vehicle is not moving or when hydraulic valve has been returned to neutral position and vehicle is traveling at 35 MPH or less.
			<b>16.</b> Hydraulic hook up for TowPlow <b>A.</b> Coupler stack to be located rear passage side of RDS body. Couplers to be ISO interchange .  <b>B.</b> II Faster 3P508G-4-12G-MC/Faster 2P508G-4-12G-FC
			<b>17.</b> Hydraulic circuit for steering and moldboard lift shall have pressure relief valve also mounted at rear passage side of RDS body.
			<b>18.</b> Detailed literature and manufacturer's specification and date sheets on PTO, Joystick Control, Spreader control crankshaft drive, hydraulic pump, valves, filters and flexible cable control system will be provided with bid. NO BID WILL BE CONSIDERED WITHOUT THE INCLUSION OF THIS INFORMATION NECESSARY TO EVALUATE THE BID.
			<b>19.</b> Hydraulic/spreader system training and support shall be provided by company representative.
			<b>A.</b> Training for operators and mechanics shall be provided by spreader control/hydraulic system representative.
			<b>1.</b> Training shall be done at any of the units, assigned locations and/or district within the State of Nebraska.
			<b>2.</b> Training session shall be a minimum of four (4) hours for operators. An additional four (4) hours of training shall be provided to mechanics for diagnostic procedures and repair of controller system.
			<b>3.</b> Training shall include basic operation, calibration procedures, and basic trouble shooting. Training to be required and provided annually for each NDOT District.
			<b>B.</b> Technical support shall be provided for systems.
			<b>1.</b> Vendor shall make a representative available to travel within the State of Nebraska and assist mechanic with system failures.
			<b>2.</b> Vendor representative shall travel to any of the units assigned location to make repairs during warranty.
			<b>20.</b> The Hydraulic/Spreader control system shall be free of RFI emissions.
			<b>A.</b> The hydraulic/spreader control system and/or installed components and equipment shall be compatible with use of NDOT mobile and/or two-way communication devices. Main communication radio operates in low band range of 47 MHz to 48 MHz, but all frequencies apply including low band, high band, UHF and VHF.
			<b>B.</b> The hydraulic/spreader control system and/or installed components and equipment shall be manufactured to meet all current SAE and/or ISO Standard applicable and/or relevant to Electromagnetic Compatibility
			<b>C.</b> NDOT will conduct testing of radio/two-way when installed in chassis. NDOT will notify vendor if normal operational parameters



YES	NO	NO & PROVIDE ALTERNATIVE	
			are not met due to degradation of signals caused by electromagnetic emissions from control system and/or installed components and equipment. Vendor shall be required to work with NDOT personnel to reduce interference level to a point acceptable to NDOT normal radio operation parameters. Vendor shall have 30 days to resolve RFI issue.
			D. Vendor and/or manufacturer will be responsible for any and all cost to replace and/or modify any parts found to cause radio frequency interference. If NDOT and vendor cannot resolve source of RFI, the unit will sent to an independent accredited lab for testing to ensure SAE and/or ISO Standards compliance. Testing shall be done to SAE and/or ISO Standard which were current at time of bid. Should the unit fail testing at the accredited lab, the vendor shall be responsible for all cost incurred for testing.
			E. If after testing by NDOT and/or accredited lab, the vendor is unable or unwilling to incur cost and correct the RFI issue to the satisfaction of NDOT, ALL ORDERS AND CORRESPONDING CONTRACT WILL BE CANCELED.
<b>NOTES/COMMENTS:</b>			

**MM. SNOWPLOW HITCH**

YES	NO	NO & PROVIDE ALTERNATIVE	
			1. Shall be heavy duty, universal quick hitch Monroe, Viking, Henke, Henderson or other equivalent approved in writing by Fleet Management prior to bid opening, with minimum four inch double acting hydraulic cylinder. Hitch may be powder coat finish or primer and paint finish.
			a. Center line hitch mounting is to be 30.5"
			b. Lower plow mount pin approximately 14 inches from grade
			c. Height of hitch mast shall be 40-44 inches from plow attachment pin to pivot of lift arm.
			2. Hitch will include attaching pins and A-frame lift arm with lifting lug or clevis.
			3. All thrust loads must be transferred to chassis frame and not to chassis axle or spring assemblies.
			4. The crankshaft driven pump must be supported and protected by this hitch assembly.
			5. Hitch to be made so that tilting hood/fenders will tilt fully forward with mast in tilted position. Mast shall be tilting design by either manual or hydraulic function.
			6. Hitch will be installed with Grade 8 bolts to chassis and as per hitch manufacturer's recommendations.
			7. A drawing of hitch to include material specifications of materials used shall be provided prior to bid award.
			a. Pump shall be located as reasonably close as possible to chassis components after bumper removal.
			b. Bumper to be put in dump body when delivered. All mounting brackets and hardware shall be left intact with bumper and shall be delivered with the same truck as which was removed from.
<b>NOTES/COMMENTS:</b>			

**NN. WING**

YES	NO	NO & PROVIDE ALTERNATIVE	
			1. Wing to have a minimum 11 foot long moldboard.
			2. Height of Moldboard shall be minimum 29 inches.
			3. Moldboard thickness to be minimum 3/16 inch.
			a. Moldboard to be made of commercial grade A569 steel or equivalent.
			b. Cutting edge of 5/8 inch by 8 inches, AASHTO punched.
			4. Moldboard bottom angle or base angle shall be a minimum 4 inch x 4 inch by ¾ inch structural angle.
			5. Minimum seven moldboard flame cut ribs.
			a. Ribs must be ½ inch thick minimum.
			b. Ribs to be one piece. Spliced ribs are unacceptable.
			6. Wing must be able to be mounted to work in conjunction with a reversible plow or a one way plow.
			a. Rear wing post shall be mounted so that clearance to dump body is no less than 1 ½ inches.
			b. Rear push arm frame assembly shall be designed for mounting on a chassis so that it is not necessary to require additional cab to body spacing.
			c. Two adjustable length push arm assemblies shall be required.
			d. Upper push arm shall have an extension spring and slide assembly to allow moldboard to trip.
			e. The wing shall be able to be mounted so that it will fold closely to the truck and shall be provided with a safety chain on the heel to secure the wing in a folded position for travel.
			f. When the wing is in the lowered plowing position, the wing shall provide sufficient tire clearance for turning left and right.
			g. All necessary parts, brackets, hardware, fittings etc. for complete and satisfactory installation of wing shall be furnished.
			h. The upper push arm shall have a built-in slide assembly for the rear cylinder pickup and attachments for rear spring assembly.
			i. The wing heel lift cylinder shall be 3 inch x 15-inch minimum.
			i. The rod diameter shall be a minimum of 2 inch and be double acting.
			ii. The moldboard/wing heel lift cylinder shall have a safety lock valve to prevent wing from falling in event of failed hoses.
			7. The front wing post shall be fabricated from a 3/8 inch thick T1 steel and must be made of two interlaced side flanges and a center web plate for additional strength. Other post must be approved prior to bid award.
			a. It shall be fabricated and reinforced in such a manner to allow the full travel of the front slide plate from the top to the bottom
			b. The front slide plate must be a minimum of ½ inch thick steel and incorporate a minimum of 5 inches mechanical float.
			c. The slide plate must be welded in permanently.
			d. The wing post cross tube is to be a minimum of 4 inch x 6 inch x ½ inch thick wall tubing.
			e. The front wing post shall be attached to the frame of the truck with ½ inch side plates bolted to the front frame extension of the truck.
			8. Hydraulics are to be compatible with truck that wings will be mounted on, two stack valve sections are required for satisfactory operation of the wing.
			a. Needs to be compatible with Joystick Control as specified in main body
			b. Toe cylinder hydraulic hoses shall be furnished with one of the listed flat face quick couplers (33.F.1.a.). quick coupler connect shall be made via bulkhead fittings mounted through a ¼ inch thick plate welded to the stationary portion of the snowplow push frame. Quick

YES	NO	NO & PROVIDE ALTERNATIVE	
			couplers shall not be installed directly to the cylinder.
			c. All the appropriate hydraulic cylinders, fittings, hardware, and other parts necessary for mounting shall be furnished.
			9. Maximum advertised weight of complete wing assembly (front wing post, moldboard and push tubes) 2, 800 pounds.
			a. Component listing with all weights for complete assembly including frames to be provided prior to bid award.
			10. One operator manual must be furnished at time of delivery with each unit.
			11. Wing moldboard is to be painted black except for plowing surface which is to be painted aluminum. Powder coating is preferred.
			a. All attaching components of the wing are to be painted black. Powder coating is preferred.
<b>NOTES/COMMENTS:</b>			

**OO. SUSPENSION**

YES	NO	NO & PROVIDE ALTERNATIVE	
			1. Vendor needs to add O.E.M. or aftermarket air bag on right side to compensate for extra right side weight of wing if necessary.
			2. Size to be installed so when air bag inflated unit sets level when wing is raised in folded-back position.
			3. Right shock absorber shall not be removed. But repositioning will be acceptable with NDOT approval.
<b>NOTES/COMMENTS:</b>			

**PP. DUMP BODY INSTALLATION**

YES	NO	NO & PROVIDE ALTERNATIVE	
			1. All dump body installations shall be made so that no body member will touch or interfere with proper alignment of the body hinge assembly, truck suspension or other components.
			2. The longitudinal truck frame members are to be cut off and properly ground at the rear of the truck chassis.
			a. A minimum 3/4-inch steel pintle plate shall be continuously welded across the width of the body's rear hinge and to the truck's frame. Minimum 3/8-inch steel plate gussets shall be continuously welded to the hitch plate at an angle toward the bottom of the hitch and to the truck's frame forwardly as far as practical or a minimum of 12 inches.
			b. The pintle plate shall be recessed approximately 3/8-inch into frame rails to allow double welding of entire plate on both sides. The pintle plate shall be frame width at pintle eye height.
			c. Double welds shall be thick, heavy duty type or additional welds will be required.
			d. Pintle plate shall not extend lower than 3 inches below lower mounting bolt of pintle hook.
			3. A pintle hitch, Holland PH-300 rated at 36 tons, shall be centrally attached with Grade 8 bolts to the pintle plate. Proper adjustment of the hitch's air cushion plunger shall be done using Holland's adjustment gauge (part number TD-03147). All installation and adjustments shall follow

YES	NO	NO & PROVIDE ALTERNATIVE	
			manufacturer's guidelines where otherwise not noted. Eye height to be approximately 28 inches from grade with air suspension at operating height.
			4. Two safety chain brackets with load capacity of 30,000 pounds each, Premier Number 9 or equivalent for use as attachment of trailer safety chain hooks.
			a. Hooks are to be welded to the right and left of pintle hitch.
			b. Reference drawing and/or pictures will be provided to vendor after award to show Nebraska Department of Transportation (NDOT) preferred placement of chain hook, trailer airline/glad-hands, and trailer electrical plug.
			5. To effectively mount our end gate material spreader, a controlling distance from a plumb line dropped from end of box floor to the rear most portion of the wheel tread must be at least 12 inches but not more than 13 inches.
			a. The frame cut-off musts also be made so as to position the face of the pintle plate 9 inches, plus or minus ½ inch forward of the rear edge of the dump box floor.
			6. Dump box, electric adjustable, lift limit, weatherproof valve control must be provided. To stop oil flow to dump box cylinder.
			a. It shall be capable of limiting overall box height from 12 feet above ground level up to maximum possible dump angle.
			7. All bare wire to bare wire electrical connections shall be properly soldered and weather sealed with heat shrink tubing.
			a. Wires from chassis to body lights shall be in flexible conduit or loom.
			8. Professional techniques and workmanship are required.
			a. No welding or cutting of chassis rails except as stated elsewhere in the specification.
			b. Welds must be chipped free of slag and thoroughly protected with yellow or black enamel as appropriate.
			c. Improper mountings, poor welding practices, the presence of slag, hydraulic oil leaks or inadequate paint coverage will be cause for rejection of any unit. In which case, the vendor will be notified to call for the vehicle and remove it from State property for remedy of defects.
<b>NOTES/COMMENTS:</b>			

**QQ. ROAD AIR TEMPERATURE SENSOR**

YES	NO	NO & PROVIDE ALTERNATIVE	
			1. A Road air temperature sensor will be installed on the truck.
			a. Unit to be wired into control panel with road and air temperature being displayed on the spreader control LCD display.
<b>NOTES/COMMENTS:</b>			

**RR. FOLD-OUT LADDER**

YES	NO	NO & PROVIDE	
-----	----	--------------	--

		ALTERNATIVE	
			1. Shall be stainless steel fabrication 1" inch square tubular stock.
			2. Rungs of stainless steel with 1-/16" inch width and to be put on right front side of body ahead of front tandem axil.
			3. Shall be made to access is from about two feet from grade with approximately four rungs.
			4. Space must be provided behind all rungs to allow for adequate toe room.
			5. When ladder is folded in upright position, it shall not extend out beyond edge of main body.
			6. Adequate latch to keep foldable portion of ladder in upright posting when traveling is required.
<b>NOTES/COMMENTS:</b>			

**SS. ROLL TARP**

YES	NO	NO & PROVIDE ALTERNATIVE	
			1. The tarp system shall be a Shurco Super Duty Shur-Lok kit or equivalent, and consist of the following minimum:
			a. 22 ounce vinyl coated tarp with tail flap.
			b. Roll-away ridge pole.
			c. .10 gauge aluminum front endcap.
			d. Aluminum latch plate.
			e. One heavy duty rear tarp bow.
			f. Three easy-off offset tarp stops.
			g. Four crank retainers.
			h. Long shur-flex crank arm may incorporate or double hinged .
			i. Front end shur-return system.
			j. Tube extension to be provided for trucks with pre-wets installed.
			2. Installation shall be such that the tarp can be secured for travel in either the open or covered mode.
<b>NOTES/COMMENTS:</b>			

**TT. AUXILIARY HEADLAMP/TUR SIGNALS**

YES	NO	NO & PROVIDE ALTERNATIVE	
			1. Two sets are required.
			a. One set shall be mounted on cab shield near front corners of cab with a heavy bracket positioning the light so that the top of light will be about same height as top of cab shield. Plow light mounting not to interfere with strobe light mounting position.
			b. One set referred to as hood lights, will be attached with a sturdy bracket preferably using existing chassis bolts to alleviate fiberglass cracking.
			i. Height of centerline of hood lights will be slightly above the top of hood.
			ii. Inner width will be slightly outside of vertical plane of hood.
			iii. Light sets shall consist of ABL PN# <b>ABL 3830-0080 Plow Light</b>

			<b>Kit</b> LED Snowplow Light with heated lens. Lights other than those above must be approved by NDOT Fleet Management prior to bid opening.
			<b>iv.</b> Two toggle switches are required to switch between chassis headlights, cab lights or hood lights.
			<b>v.</b> Use of dimmer switch in all modes required.
			<b>vi.</b> A permanent-type decal or sign shall be installed by switches indicating "chassis headlights", or "hood lights"
			<b>2.</b> Wires from lights to entrance of cab shall be in flexible conduit or loom, adequately attached and with the proper grommets.
			<b>a.</b> Additional holes are not permitted in cab for light wire entrance, unless existing manufacturer's holes in firewall or elsewhere do not allow wire entrance; NDOT FLEET MANAGEMENT must then be contacted for acceptable access.
			<b>b.</b> Wire entrance must be properly grommets or otherwise silicone sealed so as not to permit moisture entrance.
			<b>3.</b> Turn lights will be wired so they function when factory installed turn signals.
			<b>a.</b> Heavy duty flasher is required, unless original chassis flasher is recommended for the additional lights.
			<b>b.</b> Is original chassis flasher recommended for additional lights?
			<b>4.</b> A LED spotlight that is fixed for wing operation is required. Unit will be a six inch diameter, round or rectangular shaped light mounted on cab shield. Mounting of light will allow light beam to be direct to heel of wing moldboard in operating position.
<b>NOTES/COMMENTS:</b>			

**UU. CLEARANCE REFLECTORS**

YES	NO	NO & PROVIDE ALTERNATIVE	
			<b>1.</b> All reflectors used in lieu of lights shall be placed front, sides and rear as required by State and Federal laws.
<b>NOTES/COMMENTS:</b>			

**VV. CONVEX MIRRORS**

YES	NO	NO & PROVIDE ALTERNATIVE	
			<b>1.</b> Required for each front fender of Phillip Fender Guides or Velvac 8 inch round convex mirrors. An equivalent could be acceptable but must be approved in writing by NDOT Fleet Management prior to bid opening. Indicate: _____.
			<b>a.</b> Mirrors proposed must be recommended by mirror manufacturer for install on front fenders of dump truck.
			<b>b.</b> Mirrors shall be mounted so they do not interfere with auxiliary headlamps.
			<b>c.</b> Mirrors to be heated type. Please state type to be provided. _____

NOTES/COMMENTS:

**WW. TOOLBOX**

YES	NO	NO & PROVIDE ALTERNATIVE	
			1. An approximate 24 inch long by 12 inches by 14 inch waterproof unit of Knaack Weatherguard brand Model WG 525-5-01, Knapheide TBU2414A or Omaha Brand B24-B is required. Indicate: _____.
			a. Box must be sturdily mounted on chassis frame.
			b. Bidder shall note that air dryer, air tank or battery box may need to be relocated to accommodate the box.

NOTES/COMMENTS:

**XX. SAFETY EQUIPMENT**

YES	NO	NO & PROVIDE ALTERNATIVE	
			1. Electronic type back-up alarm that meets OSHA standards.
			2. Rear view camera system required as per Section R controls & instruments Line 6.
			3. Safety Strobe System installed, Whelen Strobe PN# NDORSYS1 to be used. ( see parts list below)
			a. Whelen Strobe to set up to these colors. From back view of truck. (See Section EE. Stationary Cab Shield Line 7-1)
			i. Blue strobes to be on left side of plow truck. PN#R1LPPCB
			ii. Amber strobes to be on right side of plow truck. PN#RL1PPCA
			iii. White strobes to be in center of plow truck. PN#R1LPPC
			b. See Section DD. Body line 10.C. for the following strobe location
			i. LF of Dump body 5VB02ZCD - 500 series Blue with clear lens
			ii. RF of dump Body 5VA02ZCD - 500 series Amber with clear lens
			iii. (2) 5 GROMMET grommets for 500 series

**NDORSYS1 Parts List**

Part Number	Description
R1LPPCA	AMBER MINI BAR WITH CLEAR LENS
R1LPPC	CLEAR MINI BAR
R1LPPCB	BLUE MINI BAR WITH CLEAR LENS
5VA02ZCD	500 SERIES AMBER WITH CLEAR LENS
5VB02ZCD	500 SERIES BLUE WITH CLEAR LENS
(2) 5GROMMET	GROMMETS FOR 500 SERIES
01-06879191XVC	ASSY, DOT 400-V D HEATED LENS SQUARE A-C/BTT/B-UP SS
01-026E462-51C	SUB ASSY, 400 LED B/T/T 12V
01-026F769-10A	SUB ASSY, 400 VV-SERIES AMB/CLR
01-026G397V11D	SUB ASSY, 400 BACK-UP VERT 12V
07-744043-0010	PLATE, SIDE WINDOW COVER
10-0320776-00A	LABEL, MADE IN USA FLAG
11-483984-0000	FACEPLATE, MOUNTING 400 SERIES
11-487697-1SSB	HOUSING, LTHD DOT 400 TRIPLE
13-130130-0720	NUT, 1/4-20 ELASTIC STOP BRASS
14-130186-1200	SCREW, 1/4-20 X 3/4" TORX FLAT
15-061416-2400	SCREW, 6 X 1-1/2 PPHSMS
21-3718388-020	PLUG, DOME, 1.375" HOLE DIA
68-3183725-3SB	LENS, CLEAR NON OPTIC W/ SEAL
68-3183725-5SB	LENS, RED NON OPTIC W/ SEAL

NOTES/COMMENTS:

**YY. WARRANTY**

YES	NO	NO & PROVIDE ALTERNATIVE	
			1. One year on parts and labor beginning after field assignment.
			a. As each unit is assigned for service the Department will maintain a record of assignment date.
NOTES/COMMENTS:			

**ZZ. GENERAL**

YES	NO	NO & PROVIDE ALTERNATIVE	
			1. Rolled edges or protective curved strips shall be attached to brackets and mountings of installed switches and similar devices in cab that have exposed sharp edges.
			2. Stickers, decals and similar signs shall not be affixed in cab where sun reflects from them in driver's or passenger's eyes.
			3. Dealer's decals, stickers, or other signs shall not be put on units; manufacturer's nameplates, stampings and other similar signs are acceptable.
			4. The first truck and body installation ready for delivery for each year of orders must be made available for inspection by Nebraska Department of Transportation (NDOT) personnel.
			a. Vendor representative shall accompany Nebraska Department of Transportation (NDOT) personnel during inspection.
			b. Components and parts that require vendor cutting, welding, grinding and similar operations shall not be painted prior to inspection. A light coating of primer is acceptable.
			c. Approval of the body, ladder, toolbox, lights, snowplow hitch and hydraulic mount must be obtained before additional units are assembled.
			d. The chassis, body, snowplow hitch, sander and hydraulics shall be delivered as a complete unit and ready for satisfactory operation.
			e. After the pilot inspection no changes to the chassis, dump body, body mountings, hydraulic system or any other components shall be made without documented permission from NDOT fleet management.
			5. Transportation, meals, and lodging cost for Nebraska Department of Transportation (NDOT) representatives to perform required inspection(s) shall be at the vendor's expense. Vendor/manufacturer must provide space in building to do inspection.
NOTES/COMMENTS:			

**AAA. MANUALS**

YES	NO	NO & PROVIDE ALTERNATIVE	
-----	----	--------------------------	--



			<b>1.</b> Following will be furnished with each unit delivered:
			<b>a.</b> One dump body manual and parts listing.
			<b>b.</b> One hydraulic system manual including information on schematic of system, tank, pump, valves, driveline, cables, levers and other relevant items to include operation, calibration and trouble shooting.
			<b>c.</b> May be in a printed format, CD-ROM, Flash drive or online.
			<b>2.</b> All manuals must be furnished prior to payment and delivered to Fleet Management personnel.
			<b>3.</b> Failure to deliver all manuals that are ordered may result in non-payment of ten percent (10%) of purchase order total, until all manuals are delivered.
<b>NOTES/COMMENTS:</b>			

**BBB. SPECIFICATION FORM**

YES	NO	NO & PROVIDE ALTERNATIVE	
			<b>1.</b> Successful bidder must complete form to the fullest extent possible for each unit delivered and must accompany each unit when delivered. Forms will be supplied by Nebraska Department of Transportation (NDOT) to successful bidder after purchase order is awarded.
			<b>2.</b> If vendor does not properly complete form for each unit, a sum of \$250.00 per unit will be deducted from purchase order amount.
<b>NOTES/COMMENTS:</b>			

**CCC. DELIVERY**

YES	NO	NO & PROVIDE ALTERNATIVE	
			<b>1.</b> After vendor completes pre-delivery service, vendor shall deliver the unit to NDOR, 5001 South 14 <sup>th</sup> St. Lincoln NE, between 9:00am and 3:00pm, except on Saturdays, Sundays and State Holidays.
			<b>2.</b> Each unit shall be delivered with not less than 20 gallons of fuel in tank.
			<b>3.</b> Vendor must notify NDOT Fleet Management a minimum of 24 hours prior to delivery of units. Contact number for NDOR Fleet Management are 402-479-4319, 402-479-4323, or 402-479-4304.
			<b>4.</b> Manufacturer's Statement of Origin and other pertinent purchasing documents must accompany invoice at time of delivery.
			<b>5.</b> All deliveries and pricing are to be F.O.B. 5001 South 14 <sup>th</sup> Street, Lincoln, Nebraska.
			<b>6.</b> Delivery of completed chassis with dump body is desired within 200 days of receipt of order by vendor. Delivery time beyond 200 days may result in bid not being considered. Please state delivery days here and on Invitation to Bid Contract form. Delivery days _____

**NOTES/COMMENTS:**

**DDD. V-PLOW OPTION**

This option shall meet or exceed the following requirements, which are exceptions to above specification.

YES	NO	NO & PROVIDE ALTERNATIVE	
			1. Will be a Monroe, Viking, Henke, Henderson, Falls or equivalent quick hitch with 14 inch pin height, approved in writing by Fleet Management prior to bid opening. Indicate: _____.
			2. Unit will have a 9 foot cutting width.
			3. Appropriate moldboard spread for rest of plow. State spread _____.
			4. Approximate 4 foot nose height.
			5. Approximate 6 foot 9 inch height at rear of moldboard.
			6. Minimum 8 gauge moldboard thickness and approximate weight of 2,500 pounds.
			7. Skid shoes will have maximum, feasible number of tungsten carbide inserts of minimum 3/16 inch thickness on bottom surface.
			8. V-plow will have minimum 10 inch ground clearance in raised position.
			9. V-plow will be painted flat black except plowing surface of aluminum color.
			10. V-Plow shall be fully mounted at the body builder, tested for proper fit and operation prior to shipment to NDOT.
<b>NOTES/COMMENTS:</b>			

**EEE. PLOW MOUNTING**

YES	NO	NO & PROVIDE ALTERNATIVE	
			1. Hitch will be mounted for both wing and plow(s) using Grade 8 bolts.
			2. Will include ½ inch thick steel, bolted-on, hydraulic pump guard at front part of hitch.
			3. V-plow and wing shall be mounted on unit if required.
			4. Front part of wing shall be capable of full vertical travel range, without interference from V-plow or fender, when the V-plow is in either raised or lowered position.
<b>NOTES/COMMENTS:</b>			

**FFF. HEAVY DUTY SNOWPLOW HITCH ( IN LIEU OF HITCH FROM MAIN SPECIFICATION)**

YES	NO	NO & PROVIDE ALTERNATIVE	
			1. Shall be heavy duty, power tilt design with quick hitch type with minimum

			four (4) inch hydraulic cylinder and 14 inch pin height.
			a. Pivot pin of lift arm to be 48-54 inches above quick connect pin.
			b. Compatible with V-Plow being supplied and for use with one-way snowplow.
			2. Hitch will include attaching pins and A-frame lift arm with lifting lug or clevis.
			3. All thrust loads must be transferred to chassis frame and not to chassis axle or spring assemblies.
			4. The crankshaft driven pump must be supported and protected by this hitch assembly.
			5. Hitch to be made so that tilting hood/fenders will tilt fully forward with mast in tilted position.
			6. Hitch will be installed with Grade 8 bolts to chassis and as per hitch manufacturer's recommendations.
			7. A drawing of hitch to include material specifications of materials used shall be provided prior to bid award.
			a. Pump shall be located as reasonably close as possible to chassis components after bumper removal.
			b. Bumper to be put in dump body when delivered. All mounting brackets and hardware shall be left intact with bumper and shall be delivered with the same truck as which it was removed from.
<b>NOTES/COMMENTS:</b>			

**GGG. HIGH BENCHING WING ATTACHMENT**

YES	NO	NO & PROVIDE ALTERNATIVE	
			1. Right hand wing, full hydraulic with overall length of about 11 feet.
			2. Wing will have overall length of about 11 feet.
			a. Cutting edge of ½ inch by 8 inches and reversible.
			b. Moldboard thickness minimum 8 gauge.
			c. Front frame mounted.
			d. AASHTO punched.
			e. Hydraulically operated including rear slide. Front and rear of wing shall be of power-down type.
			i. Hydraulic stack valve assembly shall have a four way section added for operation of rear slide. Provision shall be made in joystick for control of this function.
			ii. The moldboard/wing heel lift cylinder shall have a safety lock valve to prevent wing from falling in event if failed hoses.
			f. Full trip moldboard type.
			g. Skid plate of bottom of front wing post with sloped front and back is required.
			h. Skid plate of bottom of front wing post with sloped front and back is required.
			i. Minimum benching height shall not be less than 54 inches.
			j. Rear wing post shall be mounted so that clearance to dump body is no less than 1 ½ inches.
			3. Color of wing to be painted flat black except plowing surfaces to be aluminum.
			4. Cab shield may be attached to wing mast frame and sturdily reinforced. Assembly shall be constructed and bolted to frame rails with appropriate size and number of Grade 8 bolts in which case the assembly shall be sturdily braced.

YES	NO	NO & PROVIDE ALTERNATIVE	
NOTES/COMMENTS:			

**HHH. SEVERE DUTY HIGH BENCHING WING ATTACHMEN**

YES	NO	NO & PROVIDE ALTERNATIVE	
			1. Right hand wing full hydraulic with overall length of about 11 feet.
			a. Cutting edge of ½ , inch by 6 inches and reversible.
			b. Moldboard thickness minimum 8 gauge.
			c. Front frame mounted.
			d. AASHTO punched.
			e. Hydraulically operated including rear slide. Front and rear of wing shall be of power-down type.
			i. Hydraulic stack valve assembly shall have a four way section added for operation of rear slide. Provision shall be made in Joystick for control of this function.
			ii. The moldboard/wing heel lift cylinder shall have a safety lock valve to prevent wing from falling in event if failed hoses.
			iii. Rear slide will 3 stage hydraulic cylinder.
			iv. Full trip moldboard type
			v. Skid plate of bottom of front wing post with sloped front and back ls required. Skids to be minimum ½ inch thick and have a total width of at least four inches.
			2. Minimum benching height shall not be less than 80 inches.
			3. Color of wing to be painted flat black except plowing surfaces to be aluminum.
			4. Cab shield may be attached to wing mast frame and sturdily reinforced, Assembly shall be constructed and bolted to frame rails with appropriate size and number of Grade B bolts in which case the assembly shall be sturdily braced.
NOTES/COMMENTS:			

**III. PRE WET SYSTEM**

YES	NO	NO & PROVIDE ALTERNATIVE	
			1. Pre-wetter will be used to apply liquid ice control material onto granular material at the spreader spinner.
			2. Pump system shall have a design rating of 4 GPM @ 70 PSI with input of 3 GPM hydraulic flow.
			3. Tanks shall have minimum Dual 120 US gallon capacity.
			4. Tanks must mount on top of the fenders and fit in the area along the sides of the body.
			5. System must be fully tested and calibrated to a minimum 10 gallon per ton rate upon delivery to the Department. System shall be flushed and winterized with a suitable antifreeze solution to prevent damage.
			6. All components, parts, pieces, fasteners, etc., shall be manufactured from nonferrous/non-rusting materials.
			7. Liquid ice control material hoses shall be minimum ½ inch polyester braid reinforced PVC, suitable for cold weather use.
			8. All hoses and cables shall be long enough to allow the dump body tailgate to open for dumping over the spreader.
			9. Cables to be ISO IP68 NEMA 6.

**NOTES/COMMENTS:**

**JJJ. TANK**

YES	NO	NO & PROVIDE ALTERNATIVE	
			1. Tanks shall be purpose designed to fit a Department snow removal truck RDS Body. When installed it shall they shall not extend beyond the side of the fender.
			2. Wedge style tanks shall be approximately 5.5" inches wide at the top and 19.5" inches at the bottom. Height shall be approximately 22" inches; overall length shall be approximately 100" inches.
			3. Tanks shall be constructed from rotationally molded UV stabilized polyethylene. Design liquid rating shall be a minimum of 14.5 lbs. per gallon.
			4. There shall be three molded-in stiffeners, each approximately 4 inches wide, evenly spaced in the tank length. Stiffeners shall align with supporting brackets and straps.
			5. Tanks shall include 1 inch baffle vent installed at the top.
			6. Tanks shall have two top molded 3 inch NPT fill lids. Lids shall be tethered.
			7. A 4" x 8" x 6" sump shall be molded into the right side bottom. Sump shall have three molded-in female 1-1/4 inch NPT threaded ports. The molded- in ports shall be an integral part of the tank.
			8. Tanks to include two 1-1/4" NPT molded in ports on each end Ports to be located as close to the boyyom of the tank as possible.(spin weld and /or bulkhead fitting are not acceptable at this location)
			9. 1-1/4 inch ID cross over hose with fitting is required.
<b>NOTES/COMMENTS:</b>			

**KKK. FITTINGS**

YES	NO	NO & PROVIDE ALTERNATIVE	FITTINGS
			1. All anti-icing liquid fitting are to be made of glass reinforced polypropylene.
			2. A3/4 inch Y-type strainer with a stainless 20 mesh screen must be installed between the tanks and pump.
			3. A 1-1/2inch male cam lock connector shall be installed to allow bulk filling. A matching cam lock cover cap shall be provided. Bulk fill fitting must be accessible from the ground.
			4. The right rear facing port shall have a 1-1/4 NPT plug screwed into it.
			5. A 3/4 inch 3-way valve shall be installed into the suction plumbing. When this valve is closed, normal flow of the anti-ice material shall occur. When the 3- way valve is turned to the closed position and this valve opened, flush material shall be sucked into the plumbing and pumping system, thoroughly displacing all corrosive materials. An approximate 12-inch hose piece shall be attached to this fitting to allow easy flush material introduction via a plastic jug.
<b>NOTES/COMMENTS:</b>			

**LLL. PUMP SYSTEM WITH METER**

YES	NO	NO & PROVIDE ALTERNATIVE	
			1. Material pump shall be a solid brass gear type, direct coupled to the hydraulic motor that will power the pre-wetter.
			2. Pre-wetter hydraulic system shall obtain its flow directly from the valve motor manifold circuit identified for this purpose.
			3. Flow control shall be electrically controlled by the spreader control in the truck cab, allowing precise metering of the oil flow.
			4. Pump system shall incorporate a calibrated turbine style flow meter. Flow meter signal shall be sent to the spreader control, allowing a precise ground oriented liquid application rate. Rate shall be adjustable up to the limits of the pump design output.
			5. A float switch placed in the bottom of the tank to indicate low level or empty tank. Float switch shall be compatible and connected to spreader control system.
<b>NOTES/COMMENTS:</b>			

**MMM. MOUNTING SYSTEM**

YES	NO	NO & PROVIDE ALTERNATIVE	MOUNTING SYSTEM
			1. Pre-wet system shall attach to the dump body fenders via a full stainless steel framework. Frame shall fully support the tank.
			2. Polyethylene tank shall be retained in the stainless steel mounting cradle with three 3 inch wide UV stabilized nylon tie down straps. Straps shall have a heavy duty threaded I-bolt mount on each end. Bolts shall pass through the mounting framework and be tension adjustable with stainless nuts.
<b>NOTES/COMMENTS:</b>			

**NNN. NOZZLE DELIVERY SYSTEM**

YES	NO	NO & PROVIDE ALTERNATIVE	
			1. Pre-wet liquid shall travel from the pump out to be applied on the spreader spinner.
			2. Two brass nozzles, each rated 1.0 GPM flow shall be furnished and mounted on to a bracket, attached to the spreader spinner with stainless bolt. Nozzles shall be directed to spray on the centerline of the spinner.
			3. A suitable cam lock type quick connector shall be installed in the delivery line running to the nozzles. It shall be positioned in the line to approximately correspond to where the hydraulic quick connectors for the spinner assembly are, allowing the entire spinner assembly to be easily removed with the nozzle bracket assembly attached.
			4. A one-way check valve system must be installed in the delivery line directly before or at the nozzles to prevent line drain down when the system is shut-off.
<b>NOTES/COMMENTS:</b>			

**000. GENERAL**

YES	NO	NO & PROVIDE ALTERNATIVE	
			1. Rolled edges or protective curved strips shall be attached to brackets and mountings of installed switches and similar devices in cab that have exposed sharp edges.
			2. Stickers, decals and similar signs shall not be affixed in cab where sun reflects from them in driver's or passenger's eyes.
			3. Dealer's decals, stickers, or other signs shall not be put on units; manufacturer's nameplates, stampings and other similar signs are acceptable.
			4. The first truck and body installation ready for delivery for each year of orders must be made available for inspection by NDOR personnel. Inspection of trucks built with pusher axle and 16 foot body will be done as a separate inspection. This inspection may be scheduled to coincide with the standard B25 orders.
			a. Vendor representative shall accompany Nebraska Department of Transportation personnel during inspection.
			b. Components and parts that require vendor cutting, welding, grinding and similar operations shall not be painted prior to inspection. A light coating of primer is acceptable.
			c. Approval of the body, ladder, toolbox, lights, snowplow hitch and hydraulic mount must be obtained before additional units are assembled.
			d. The chassis, body, snowplow hitch, sander and hydraulics shall be delivered as a complete unit and ready for satisfactory operation.
			e. After the pilot inspection no changes to the chassis, dump body, body mountings, hydraulic system or any other components shall be made without documented permission from NDOR fleet management.
			5. Transportation, meals, and lodging cost for Nebraska Department of Transportation representatives to perform required inspection(s) shall be at the vendor's expense. Vendor/manufacturer must provide space in building to do inspection.
<b>NOTES/COMMENTS:</b>			

**PPP. RIGHT WING MID MOUNT PATROL WING**

YES	NO	NO & PROVIDE ALTERNATIVE	
			1. Wing to have a minimum 8 - foot long moldboard.
			2. Height of Moldboard inboard shall be minimum 24 inches and outboard height shall be a minimum 28 inches. Measurements include the eight inch cutting edge installed.
			3. Moldboard thickness to be minimum 3/16 inch.
			a. Moldboard to be made of commercial grade A36 steel or equivalent.
			4. Cutting edge of 5/8 inch by 8 inches, AASHTO punched.
			5. Moldboard bottom angle or base angle shall be a minimum 4" x 4" x 3/4" structural angle with a triangle shaped 3" x 3" x 1/2" plate gusset between each bolt hole.
			6. Minimum seven moldboard flame cut ribs.
			a. Ribs must be 3/8-inch thick minimum.
			b. Ribs to be one-piece. Spliced ribs are unacceptable.
			c. Ribs are to be continuously welded.
			7. Moldboard top formed channel shall be a minimum 2 1/2" x 1".
			8. Wing light position to light moldboard mount as not to reflect off exhaust.

**NOTES/COMMENTS:**

**QQQ. PUSH ARM**

YES	NO	NO & PROVIDE ALTERNATIVE	
			1. The outer tube of the push arm is to be a minimum 3 ½" O.D. schedule 80 pipe.
			2. The inner shaft shall be a solid 2 7/8" O.D. – 1045 steel shaft.
			3. The wing shall have a single spring cushioned push arm.
			4. The push arm shall be adjustable and have a safety shear pin.
			5. Both ends of the arm will have fabricated pivot blocks.
<b>NOTES/COMMENTS:</b>			

**RRR. WING POST**

YES	NO	NO & PROVIDE ALTERNATIVE	
			1. The front wing cross tube shall be fabricated from 4" x 6" x ½" wall structural tube which spans both frame rails of the truck.
			2. The outboard end of the cross tube shall be constructed from 7" structural I-beam with a minimum 3 5/8" flange vertically attached so as to be the foundation of a front wing post assembly.
			3. The I-beam shall be reinforced with two fully welded diagonal pieces of 3" x 3/8" steel bar from the cross tube to the I-beam. These shall be further reinforced with a 1" x ½" piece of steel bar welded to the face.
			4. The front mast slide to be ¾" plate steel and is a minimum of 5 7/8" wide.
			5. The front of the moldboard shall be mounted to the front slide plate with a single 1-1/2" diameter grade #5 bolt with a top lock nut. The slide plate to allow for 5 inch float.
			6. The front cross tube shall be mounted under the truck frame and supported by two steel plates a minimum of ½" x 12" x 24".
			7. The front of the wing is raised by a single 4"ID x 12" double acting lift cylinder.
			8. The cylinder attaches to the backside of the front mast at the top with a 1-1/4" grade #5 bolt and at the bottom with a minimum 1" diameter pin. It is mounted through two gussets welded to both the I-beam and cross tube for structural rigidity.
			9. The slide assembly will allow mounting of the moldboard by means of a ¾" reinforced steel plate approximately 10" x 18" which is mounted to the slide assembly with a single heat treated steel pin approximately 1-1/2" x 12".
			10. The rear wing cross tube assembly shall be fabricated from 6" x 4" x ½" mild steel tubing.
			11. The cross tube shall be mounted underneath truck by two steel mounting plates approximately 12" x 28" x ½" with flame cut holes for the cross tube to pass through.
			12. The rear lift wing cylinder shall be a single 4" ID x 10" double acting hydraulic cylinder attached to the moldboard's mechanical float linkage.
			a. No cable or chains acceptable hydraulically operated only.
			b. The moldboard/wing heel lift cylinder shall have a lock valve to prevent wing from falling in event of failed hoses.



YES	NO	NO & PROVIDE ALTERNATIVE	
NOTES/COMMENTS:			

**SSS. HYDRAULICS**

YES	NO	NO & PROVIDE ALTERNATIVE	
			1. To be compatible with the truck hydraulics. Two stack valve sections are required for satisfactory operation of the wing.
			2. Needs to be compatible with Joystick Control as specified in main body.
			3. Toe cylinder hydraulic hoses shall be furnished with one of the listed flat face quick couplers (33.F.1.a.). Quick coupler connect shall be made via bulkhead fittings mounted through a 1/4-inch thick plate welded to the stationary portion of the snowplow push frame. Quick couplers shall not be installed directly to cylinder.
			4. All the appropriate hydraulic cylinders, fittings, hardware and other parts necessary for mounting shall be furnished.
NOTES/COMMENTS:			

**TTT. MANUALS**

YES	NO	NO & PROVIDE ALTERNATIVE	
			1. One operator manual must be furnished at time of delivery with each unit.
			2. All manual(s) must be furnished prior to payment and delivered to Fleet Management, Equipment Data Coordinator. Failure to deliver all manuals that are ordered may result in non-payment of ten percent of purchase order total until all manuals are delivered.
NOTES/COMMENTS:			

**UUU. COLOR**

YES	NO	NO & PROVIDE ALTERNATIVE	
			1. Wing moldboard is to be painted black except plowing surfaces to be painted aluminum. Powder coating is preferred.
			2. All attaching components of the wing are to be painted black. Powder coating is preferred.
NOTES/COMMENTS:			

**VVV. WARRANTY**

YES	NO	NO & PROVIDE ALTERNATIVE	
			1. Manufacturer's standard warranty shall apply and be for at least one year.
			2. Dealer's decals, stickers or other signs shall not be on unit(s); manufacturer's nameplates, stampings and other similar signs are acceptable.

**NOTES/COMMENTS:**

**WWW. LEFT HAND MID-MOUNT PATROL WING**

YES	NO	NO & PROVIDE ALTERNATIVE	
			1. Wing shall be mounted behind cab and forward of tandem axle on driver's side of chassis. Wing mounting will not interfere with entry into cab.
			2. Chassis vendor and body vendor will be responsible for repositioning components such as fuel tank, battery box, air tanks, etc. to allow for ample free area for proper mounting of wing frame to left hand side of chassis.
<b>NOTES/COMMENTS:</b>			

**XXX. WING**

YES	NO	NO & PROVIDE ALTERNATIVE	
			1. Wing to have a minimum 8 - foot long moldboard.
			2. Height of Moldboard inboard shall be minimum 24 inches and outboard height shall be a minimum 28 inches. Measurements include the eight inch cutting edge installed.
			3. Moldboard thickness to be minimum 3/16 inch.
			a. Moldboard to be made of commercial grade A36 steel or equivalent.
			4. Cutting edge of 5/8 inch by 8 inches, AASHTO punched.
			5. Moldboard bottom angle or base angle shall be a minimum 4 inch x 4 inch by 3/4 inch structural angle with a triangle shaped 3" x 3" x 1/2" plate gusset between each bolt hole.
			6. Minimum seven moldboard flame cut ribs.
			a. Ribs must be 3/8-inch thick minimum.
			b. Ribs to be one-piece. Spliced ribs are unacceptable.
			c. Ribs are to be continuously welded.
			7. Moldboard top formed channel shall be a minimum 2 1/2" x 1".
			8. Wing light position to light moldboard mount as not to reflect off exhaust.
<b>NOTES/COMMENTS:</b>			

**YYY. PUSH ARM**

YES	NO	NO & PROVIDE ALTERNATIVE	
			1. The outer tube of the push arm is to be a minimum 3 1/2" O.D. schedule 80 pipe.
			2. The inner shaft shall be a solid 2 7/8" O.D. – 1045 steel shaft.
			3. The wing shall have a single spring cushioned push arm.
			4. The push arm shall be adjustable and have a safety shear pin.
			5. Both ends of the arm will have fabricated pivot blocks.
<b>NOTES/COMMENTS:</b>			

**ZZZ. WING POST**

YES	NO	NO & PROVIDE ALTERNATIVE	
			1. The front wing cross tube shall be fabricated from 4" x 6" x 1/2" wall structural tube which spans both frame rails of the truck.
			2. The outboard end of the cross tube shall be constructed from 7" structural I-beam with a minimum 3 5/8" flange vertically attached so as to be the foundation of a front wing post assembly.
			3. The I-beam shall be reinforced with two fully welded diagonal pieces of 3" x 3/8" steel bar from the cross tube to the I-beam. These shall be further reinforced with a 1" x 1/2" piece of steel bar welded to the face.
			4. The front mast slide to be 3/4" plate steel and is a minimum of 5 7/8" wide.
			5. The front of the moldboard shall be mounted to the front slide plate with a single 1-1/2" diameter grade #5 bolt with a top lock nut. The slide plate to allow for 5 inch float.
			6. The front cross tube shall be mounted under the truck frame and supported by two steel plates a minimum of 1/2" x 12" x 24".
			7. The front of the wing is raised by a single 4"ID x 12" double acting lift cylinder.
			8. The cylinder attaches to the backside of the front mast at the top with a 1-1/4" grade #5 bolt and at the bottom with a minimum 1" diameter pin. It is mounted through two gussets welded to both the I-beam and cross tube for structural rigidity.
			9. The slide assembly will allow mounting of the moldboard by means of a 3/4" reinforced steel plate approximately 10" x 18" which is mounted to the slide assembly with a single heat treated steel pin approximately 1-1/2" x 12".
			10. The rear wing cross tube assembly shall be fabricated from 6" x 4" x 1/2" mild steel tubing.
			11. The cross tube shall be mounted underneath truck by two steel mounting plates approximately 12" x 28" x 1/2" with flame cut holes for the cross tube to pass through.
			12. The rear lift wing cylinder shall be a single 4" ID x 10" double acting hydraulic cylinder attached to the moldboard's mechanical float linkage.
			a. No cable or chains acceptable, hydraulically operated only.
			b. The moldboard/wing heel lift cylinder shall have a lock valve to prevent wing from falling in event of failed hoses.
<b>NOTES/COMMENTS:</b>			

**AAAA. MOTOR VEHICLE INDUSTRIES REGULATION ACT**

YES	NO	NO & PROVIDE ALTERNATIVE	
			1. All Bidders must comply with the licensing requirements for motor vehicle dealers established under the Motor Vehicle Industries Regulation Act, Nebraska Revised Statutes, § Chapter 60, Article 14 at time of bid. Bids will only be accepted from Bidders who are fully compliant with the Motor Vehicle Industries Regulation Act, Chapter 60, Article 14.
<b>NOTES/COMMENTS:</b>			

**BBBB. ANNUAL USAGE, ESTIMATED**

YES	NO	NO & PROVIDE ALTERNATIVE	

			1. Annual usage figures provided are estimates and are not to be construed as either a minimum or maximum purchase quantity. The orders shall be for the actual quantities of each item ordered by or for any agency during the life of the contract. Vendor shall not impose minimum order requirements.
			2. 30 units per contract year
<b>NOTES/COMMENTS:</b>			

**CCCC. USAGE REPORT**

YES	NO	NO & PROVIDE ALTERNATIVE	
			1. The vendor shall, upon request by the State of Nebraska, provide an annual usage report of this contract by state agencies. Information will include agency name, item, and dollar amount. Information may be requested at any time by the State Purchasing Bureau, but may typically be requested at the end of the contract period or upon renewal of the contract, or at other intervals (monthly, quarterly, etc.) as determined by the State.
<b>NOTES/COMMENTS:</b>			

**DDDD. DELIVERY ARO**

YES	NO	NO & PROVIDE ALTERNATIVE	
			1. Delivery desired within 200 days after receipt of order(s).  At the time of delivery, a designated State of Nebraska employee will sign the "invoice/packing slip." This signature will only indicate that the order has been received and that the items actually delivered agree with the delivery invoice. This signature does not indicate all items were received in good condition and/or that there is not possible hidden damage.
<b>NOTES/COMMENTS:</b>			

**EEEE. ORDERS**

YES	NO	NO & PROVIDE ALTERNATIVE	
			1. Orders will be placed either by, phone, fax, e-mail or Internet (if available and not to the exclusion of the other methods). All orders must reference a purchase order number and the purchase order number must be referenced on the packing slip, and invoice. Invoices are to be sent to the "Invoice to" address on the purchase order.
<b>NOTES/COMMENTS:</b>			

**FFFF. QUALITY**

YES	NO	NO & PROVIDE ALTERNATIVE	
-----	----	--------------------------	--

			<ol style="list-style-type: none"> <li>1. Product quality must meet specifications and be consistent for the term of the contract. A guarantee of satisfactory performance by the supplier and meeting delivery dates are considered to be an integral part of the purchase contract resulting from this bid invitation. All materials must be of first quality, under standard production by the manufacturer and be of standard design, complete as regularly advertised and marketed and be of proven performance. Products are to be fully guaranteed and may be returned for full credit or replacement (at the State's option) for any reason during the initial warranty period with no additional charges for shipping or restocking.</li> </ol>
<b>NOTES/COMMENTS:</b>			

**GGGG. VIKING CIVES TOWFLOW**

YES	NO	NO & PROVIDE ALTERNATIVE	
			<ol style="list-style-type: none"> <li>1. THE VIKING CIVES 26' TOW PLOW TRAILER WITH MATERIAL SPREADER SHALL BE THE LATEST CURRENT MODEL OF PROVEN PERFORMANCE AND UNDER STANDARD PRODUCTION BY MANUFACTURER AND IS TO BE OF STANDARD DESIGN, COMPLETE AS REGULARLY ADVERTISED AND MARKETED INCLUDING ALL SPECIFIED ACCESSORIES, TOOLS AND SPECIAL FEATURES. All necessary parts for satisfactory operation of the equipment whether or not they may be specifically mentioned below. Complete detailed specification and advertised data sheets with cuts or photographs should be attached to the invitation to bid on the identical equipment proposed. ANY INFORMATION NECESSARY TO SHOW COMPLIANCE WITH THESE SPECIFICATIONS. IN ADDITION TO INFORMATION GIVEN ON ADVERTISING DATA SHEETS, SHOULD BE SUPPLIED IN WRITING AND ATTACHED TO THE INVETAION TO BID. The Viking Cives 26' Tow Plow trailer with material spreader must meet or exceed the following requirements.</li> </ol>
<b>NOTES/COMMENTS:</b>			

**HHHH. FRAME AND MOLDBOARDS**

YES	NO	NO & PROVIDE ALTERNATIVE	
			1. Swivel tongue to control offset.
			2. One (1) 12 foot moldboard.
			3. One (1) 14 foot moldboard
			4. Moldboards to be 10 gauge steel with 3/8" poly overlay.
			5. Moldboard to be approximately 30" high.
			6. Moldboards to be raised and lowered by hydraulic cylinders.
			7. Moldboard base angle to be AASHTO punched to accept all standard cutting edges.
<b>NOTES/COMMENTS:</b>			

**III. WEIGHT**

YES	NO	NO & PROVIDE ALTERNATIVE	
			1. Gross allowable trailer weight of 32,000 pounds
<b>NOTES/COMMENTS:</b>			

**JJJJ. AXLES**

YES	NO	NO & PROVIDE ALTERNATIVE	
			1. Dual Arvin Meritor 16,000 Pound steering axles w/connecting linkage.
			2. ABS air brake system.
			3. Solid suspension.
			4. Fenders over tires.
			5. Four (4) TIRES TO BE 385/r22.5.
			a. Tires must be Goodyear, Michelin, Bridgestone, Firestone, Continental or General and shall carry said company name. State tire be bid: _____
			6. Hydraulic steering of axles to deploy Tow Plow to approximately 30 degrees.
<b>NOTES/COMMENTS:</b>			

**KKKK. HYDRAULICS**

YES	NO	NO & PROVIDE ALTERNATIVE	
			1. Vendor will minimize the number of critical rub points for hydraulic hoses. Where critical rub points exist, they shall be wrapped with spiral metal or adequate rubber wrap.
			2. Only steel wire braided hoses are acceptable.
			3. Hoses to be ISO 16028 flat face interchange couplings. Example of couplers:
			a. Faster 3P508G-4-12G-MC/2P508G-4-12G-FC
			b. Couplers to meet ISO 9227 standards to minimum of 400 hours salt spray test.
			4. Hoses with one of the above listed couplers (one male and one female) shall be installed on each of the following.
			a. Steering cylinder.
			b. Raise/lower cylinder.
			c. Spreader spinner.
			d. Pre-Wet.
<b>NOTES/COMMENTS:</b>			

**LLLL. LIGHTS**

YES	NO	NO & PROVIDE ALTERNATIVE	
			1. Federal safety lights and reflectors required.
			2. Rear stop/turn/tail and marker lights in swivel mast, which remains perpendicular to the travel lane.
			3. Two pedestal with warning light/beacons installed per NDOT specification on color and strobe
			4. Light mounted on top middle of tow plow moldboard shining towards heel of plow. Light to be shielded from snow and ice.
<b>NOTES/COMMENTS:</b>			

**MMMM. MATERIAL SPREADER**

YES	NO	NO & PROVIDE ALTERNATIVE	
			1. Constructed from ¼ Stainless steel.
			2. Approximately 7.8 cubic yards.
			3. 24 inch wide conveyor.
			4. Front discharge spinner assembly.
			5. Gear box to be 50:1.
			6. Body top screens.
			7. Conveyor motor sensor with 180 max pulse count.
			8. All spreader control harnessing shall meet ISO IP68 and NEMA6 standards. The connectors should be die cast E-coated and be designed to have NO corrosion after 500 hours in 35C salt spray.
			9. Sealed harness with a length capable of reaching rear of truck to include M-12 plug.
<b>NOTES/COMMENTS:</b>			

**NNNN. ROLL TARP**

YES	NO	NO & PROVIDE ALTERNATIVE	
			1. The tarp system shall be a Shurco Super Duty Shur-Lok kit or equivalent and consist of the following minimums:
			a. 22-ounce vinyl coated tarp with tail flap.
			b. Roll-away ridge pole.
			c. Stainless steel front endcap.
			d. Aluminum latch plate.
			e. One heavy duty rear tarp bow.
			f. Three easy-off offset tarp stops
			g. Four crank retainers.
			h. Long Surfex crank arm.
			i. Front end shur-return system.
			2. Installation shall be such that the tarp can be secured for travel in either the open or covered mode.

**NOTES/COMMENTS:**

**O000. PRE WET SYSTEM**

YES	NO	NO & PROVIDE ALTERNATIVE	
			1. 325 gallon poly tank mounted to the tow plow.
			2. Tank to have low level float switch to signal spreader control when empty.
			3. Pre-wetter will be used to apply liquid ice control material onto granular material at the spinner spreader.
			4. All components, parts pieces fasteners etc. shall be manufactured with nonferrous/non-rusting materials.
			5. Liquid ice control material hoses shall be ½ polyester braided reinforced hose. Suitable for cold weather use.
			6. Liquid rate control to be separate from truck pre wet.
			7. Two brass nozzles each rated 2.0GPM flow shall be mounted onto bracket attached to the spreader spinner with stainless bolts. Nozzles shall be directed to spray on the centerline of the spinner.
			8. System must be fully tested and calibrated to a 10 gallon per ton rate upon delivery to the department. System shall be flushed and winterized with suitable antifreeze solution to prevent damage.
<b>NOTES/COMMENTS:</b>			

**PPPP. PRE WET PUMP SYSTEM WITH FLOW METER**

YES	NO	NO & PROVIDE ALTERNATIVE	
			1. Material pump shall be a solid brass gear type, direct coupled to the hydraulic motor that will power the pre-wetter.
			2. Pump system shall incorporate a calibration turbine style flow meter precise ground oriented liquid application rate. Rate shall be adjustable to the limits of the pump design output.
			3. Pump, flow meter and associated plumbing to be enclosed in a fiberglass weather resistant enclosure.
<b>NOTES/COMMENTS:</b>			

**QQQQ. MANUALS**

YES	NO	NO & PROVIDE ALTERNATIVE	



			1. One operator manual must be furnished at time of delivery with each unit.
			2. All manual(s) must be furnished prior to payment and delivered to Fleet Management, Equipment Data Coordinator. Failure to deliver all manuals that are ordered may result in non-payment of ten percent of purchase order total until all manuals are delivered.
<b>NOTES/COMMENTS:</b>			

**RRRR. MISCELLANEOUS**

YES	NO	NO & PROVIDE ALTERNATIVE	
			1. The bidder should submit with their bid a list of special tools they will furnish with each machine.
			2. Dealer's decals, stickers or other signs shall not be affixed to units: manufacture's nameplate, stamping and other similar, signs acceptable.
			3. Dealer pre-delivery services required.
			4. Color-Plow shall be painted to match OEM chassis, Chassis vendor to provide OEM paint code to Viking-Cives.
			5. Professional techniques and workmanship are required.
			a. No welding or cutting of chassis rails except as stated elsewhere in specifications.
			b. Welds must be chipped free of slag and thoroughly protected with yellow or black enamel as appropriate.
			c. Improper mounting, poor welding practices, the presence of slag, hydraulic oil leaks or inadequate paint coverage will be cause for rejection of any unit. In which case, the vendor will be notified to call for the vehicle and remove it from State property for remedy of defects.
<b>NOTES/COMMENTS:</b>			

**SSSS. WARRANTY**

YES	NO	NO & PROVIDE ALTERNATIVE	
			1. Manufacturer's usual warranty shall apply, and shall be in effect of a minimum of one year from the date the equipment was placed in services.
			2. Vendor shall be responsible for all repairs to include parts, and labor during the 12 month usual warranty period.
			3. All transportation costs to and from the nearest authorized repair facility will be the responsibility of Nebraska Department of Transportation.
			4. Prior to the awarding of, or entering into any agreement or contract it shall be the responsibility of manufacturer and/or the successful bidder to warrant to the State of Nebraska, in writing, that it has factory authorized dealers in the State of Nebraska who will provide warranty/services and repair work without undue delay.

**NOTES/COMMENTS:**

**TTTT. SPECIFICATION FORM**

YES	NO	NO & PROVIDE ALTERNATIVE	
			1. Successful bidder will be required to complete a form to the fullest extent possible for each unit and must accompany each unit when delivered.
			2. Forms will be supplied by Department of Transportation to successful bidder after purchase orders is awarded.

**NOTES/COMMENTS:**

**Form A**  
**Vendor Contact Sheet**  
**Invitation To Bid Number 6581 OF**

Form A should be completed and submitted with each response to this solicitation. This is intended to provide the State with information on the Vendor's name and address, and the specific person(s) who are responsible for preparation of the Vendor's response.

<b>Preparation of Solicitation Contact Information</b>	
<b>Vendor Name:</b>	
<b>Vendor Address:</b>	
<b>Contact Person &amp; Title:</b>	
<b>E-mail Address:</b>	
<b>Telephone Number (Office):</b>	
<b>Telephone Number (Cellular):</b>	
<b>Fax Number:</b>	

Each Vendor shall also designate a specific contact person who will be responsible for responding to the State if any clarifications of the Vendor's response should become necessary.

<b>Communication with the State Contact Information</b>	
<b>Vendor Name:</b>	
<b>Vendor Address:</b>	
<b>Contact Person &amp; Title:</b>	
<b>E-mail Address:</b>	
<b>Telephone Number (Office):</b>	
<b>Telephone Number (Cellular):</b>	
<b>Fax Number:</b>	

**Form B**  
**Notification of Intent to Attend Pre-Bid Conference**  
**Invitation To Bid Number 6581 OF**

<b>Vendor Name:</b>	
<b>Vendor Address:</b>	
<b>Contact Person:</b>	
<b>E-mail Address:</b>	
<b>Telephone Number:</b>	
<b>Fax Number:</b>	
<b>Number of Attendees:</b>	

The "Notification of Intent to Attend Pre-Bid Conference" form should be submitted to SPB via e-mail ([as.materielpurchasing@nebraska.gov](mailto:as.materielpurchasing@nebraska.gov)),

**ADDENDUM ONE  
REVISED SCHEDULE OF EVENTS  
&  
REVISION OF SECTION I PROCUREMENT PROCEDURE**

Date: September 9<sup>th</sup>, 2021  
 To: All Bidders  
 From: Rob Taylor, Procurement Officer  
 AS Materiel Purchasing  
 RE: Addendum for ITB 6581 OF to be opened October 8<sup>th</sup>, 2021 at 2:00 p.m. Central

**1. Schedule of Events**

The State expects to adhere to the tentative procurement schedule shown below. It should be noted, however, that some dates are approximate and subject to change. It is the Bidder's responsibility to check the State Purchasing Bureau website for all addenda or amendments.

ACTIVITY		DATE/TIME
1.	Release solicitation	September 7 <sup>th</sup> , 2021
2.	Last day to submit written questions (Round One) <b>Upload electronic submissions via ShareFile to:</b> <a href="https://nebraska.sharefile.com/r-r4a230761fdb749749f94d081606a0bfb">https://nebraska.sharefile.com/r-r4a230761fdb749749f94d081606a0bfb</a>	<b>September 13<sup>th</sup>, 2021</b>
3.	State responds to written questions (Round One) through a solicitation "Addendum" and/or "Amendment" to be posted to the Internet at: <a href="http://das.nebraska.gov/materiel/purchasing.html">http://das.nebraska.gov/materiel/purchasing.html</a>	<b>September 15<sup>th</sup>, 2021</b>
4.	Last day to submit "Notification of Intent to Attend Pre-Bid Conference"	<b>September 15<sup>th</sup>, 2021</b>
5.	<b>Mandatory Pre-Bid Conference (Electronic/Virtual)</b> <b>Join Zoom Meeting</b> <a href="https://us02web.zoom.us/j/82945111036?pwd=SFNDQkZRZ0NNTGxaOXdtVWFOQmxkUT09">https://us02web.zoom.us/j/82945111036?pwd=SFNDQkZRZ0NNTGxaOXdtVWFOQmxkUT09</a> <b>Meeting ID:</b> 829 4511 1036 <b>Passcode:</b> 330873  <i>* Registration Advisement: Bids will only be accepted from those Companies/Firms who attend the Mandatory Pre-Bid Conference and are placed on the registered list during roll call of the conference.</i>	September 13, 2021 1:00 PM Central Time  <b>September 17<sup>th</sup>, 2021</b> 1:00 PM Central Time
6.	Last day to submit written questions (Round Two) <b>Upload electronic submissions via ShareFile to:</b> <a href="https://nebraska.sharefile.com/r-re446bd873cba409ea63e4b0b4d1bc699">https://nebraska.sharefile.com/r-re446bd873cba409ea63e4b0b4d1bc699</a>	<b>September 23, 2021</b>
7.	State responds to written questions (Round Two) through a solicitation "Addendum" and/or "Amendment" to be posted to the Internet at: <a href="http://das.nebraska.gov/materiel/purchasing.html">http://das.nebraska.gov/materiel/purchasing.html</a>	<b>September 28, 2021</b>

	ACTIVITY	DATE/TIME
8.	<p><b>Electronic Bid Opening</b></p> <p><b>Topic: 6581 OF - TANDEM AXLE CHASSIS, MINIMUM 60,000 GVWR WITH RDS DUMP BODY, HYDRAULICS, PLOW HITCH.</b></p> <p><b>Join Zoom Meeting</b></p> <p><a href="https://us02web.zoom.us/j/87120179312?pwd=YXpKWHBzdDNOQStPZk1BMjNVZ1JEz09">https://us02web.zoom.us/j/87120179312?pwd=YXpKWHBzdDNOQStPZk1BMjNVZ1JEz09</a></p> <p><b>Meeting ID: 871 2017 9312</b></p> <p><b>Passcode: 921167</b></p> <p><b>Upload electronic submissions via ShareFile to:</b></p> <p><a href="https://nebraska.sharefile.com/r-r52e8166f202b4241af62af1fc0e8e5e4">https://nebraska.sharefile.com/r-r52e8166f202b4241af62af1fc0e8e5e4</a></p>	<p>October 8<sup>th</sup>, 2021 2:00 PM Central Time</p>
9.	<p>Post "Notification of Intent to Award" to Internet at: <a href="http://das.nebraska.gov/materiel/purchasing.html">http://das.nebraska.gov/materiel/purchasing.html</a></p>	TBD
10.	<p>Contract award</p>	TBD

**2. Revision of Section I Procurement Procedure**

The following articles are hereby added to Section I

**Z. PRE-PROPOSAL CONFERENCE**

A pre-proposal conference will be held per the Schedule of Events. Attendance at the pre-proposal conference is mandatory in order to submit a bid. Vendors will have an opportunity to ask questions at the conference to assist in the clarification and understanding of the solicitation requirements. Questions that have a material impact on the solicitation or solicitation process, and relevant to all Vendors will be answered in writing and posted at <http://das.nebraska.gov/materiel/purchasing.html>. An answer must be posted to be binding on the State. The State will attempt to provide verbal answers to questions that do not impact the ITB or process, and are only of interest to an individual contractor during the conference. If a Contractor feels it necessary to have a binding answer to a question that was answered verbally, the question should be submitted in writing per the Schedule of Events.

**AA. NOTICE OF INTENT TO ATTEND MANDATORY PRE-BID CONFERENCE**

Vendors should notify SPB of their intent to attend by submitting a "Notification of Intent to Attend the Pre-Bid Conference Form" (see Form B) by email at [as.materielpurchasing@nebraska.gov](mailto:as.materielpurchasing@nebraska.gov)

**This Addendum will become part of the proposal and should be acknowledged with the ITB.**

## ADDENDUM TWO, FOR ITB 6581 OF

Date: September 15, 2021

To: All Bidders

From: Robert Taylor, Buyer  
AS Materiel State Purchasing Bureau

RE: Addendum for Invitation to Bid 6581 OF to be opened October 08, 2021 at 2:00 P.M. Central Time

### ITB

Following are the changes made to the above mentioned ITB. The changes are to be considered as part of the Invitation to Bid. It is the Bidder's responsibility to check the State Purchasing Bureau website for all addenda or amendments.

<u>Question Number</u>	<u>ITB Section Reference</u>	<u>ITB Page Number</u>	<u>Change</u>	<u>State Response</u>
1			How is the State going to deal with extended leadtimes and orderboards and annual price increases?	The State will work with the awarded Vendor on production lead-times. Price increases procedure is in Section II of the ITB. (terms and conditions)
2			Will the State accept a Volvo I Shift in lieu of the Allison 4000?	Bid as per specification
3			Will the State give any cost benefit if a stainless steel fuel tank is bid?	Will discuss at the mandatory pre bid conference.  See schedule of events for date/time and login information.
4		38	Is the 5.5-6.0 cubic inch pump what is desired or the bigger 8.75? OR Both?	Will discuss at the mandatory pre bid conference.  See schedule of events for date/time and login information.
5		38	Do we quote the 5.5-6.0 with the RDS valve on this bigger chassis and option the Tow Plow options?	Will discuss at the mandatory pre bid conference.  See schedule of events for date/time and login information.

6		38	Do you want the RDS valve quoted with an adder for the TP sections on this Chassis?	Will discuss at the mandatory pre bid conference.  See schedule of events for date/time and login information.
7			Does the 3-joystick package run the Hoist, Plow, Tow plow OR Hoist, Plow, Wing with a Tow plow delete?	Will discuss at the mandatory pre bid conference.  See schedule of events for date/time and login information.
8			Does the State want a 3-joystick package AND a 5-joystick package submitted in Lieu of the single joystick?	Will discuss at the mandatory pre bid conference.  See schedule of events for date/time and login information.
9			Do you want an option for a hydraulic shaker or vibrator? If so, how do you want it powered? Off the hydraulic valve, separate solenoid valve?	Will discuss at the mandatory pre bid conference.  See schedule of events for date/time and login information.
10			Would it be possible to move the opening date for these Contracts out a couple of weeks, it will be almost impossible to get body quotes from venders in this short of time frame as they have to get pricing from several suppliers to finish their final quote back to us for completion of total bids, and because there are three separate bid all due about the same time it would be very helpful to extend the opening date.	Will discuss at the mandatory pre bid conference.  See schedule of events for date/time and login information.

This addendum will become part of the ITB and should be acknowledged with the Invitation to Bid



## ADDENDUM THREE REVISED SCHEDULE OF EVENTS

Date: September 17<sup>th</sup>, 2021

To: All Bidders

From: Rob Taylor, Procurement Officer  
AS Materiel Purchasing

RE: Addendum for ITB 6581 OF to be opened ~~October 8<sup>th</sup>, 2021~~ **October 29<sup>th</sup>, 2021** at 2:00 p.m. Central

### 1. Schedule of Events

The State expects to adhere to the tentative procurement schedule shown below. It should be noted, however, that some dates are approximate and subject to change. It is the Bidder's responsibility to check the State Purchasing Bureau website for all addenda or amendments.

	ACTIVITY	DATE/TIME
6.	Last day to submit written questions (Round Two) <b>Upload electronic submissions via ShareFile to:</b> <a href="https://nebraska.sharefile.com/r-re446bd873cba409ea63e4b0b4d1bc699">https://nebraska.sharefile.com/r-re446bd873cba409ea63e4b0b4d1bc699</a>	<del>September 23, 2021</del> <b>September 24<sup>th</sup>, 2021</b>
7.	State responds to written questions (Round Two) through a solicitation "Addendum" and/or "Amendment" to be posted to the Internet at: <a href="http://das.nebraska.gov/materiel/purchasing.html">http://das.nebraska.gov/materiel/purchasing.html</a>	<del>September 28, 2021</del> <b>October 1<sup>st</sup>, 2021</b>
8.	<b>Electronic Bid Opening</b> <b>Topic: 6581 OF - TANDEM AXLE CHASSIS, MINIMUM 60,000 GVWR WITH RDS DUMP BODY, HYDRAULICS, PLOW HITCH.</b> <b>Join Zoom Meeting</b> <a href="https://us02web.zoom.us/j/87120179312?pwd=YXpKWHBzdDNOQStPZk1BMjNVZ1JEdz09">https://us02web.zoom.us/j/87120179312?pwd=YXpKWHBzdDNOQStPZk1BMjNVZ1JEdz09</a> <b>Meeting ID: 871 2017 9312</b> <b>Passcode: 921167</b> <b>Upload electronic submissions via ShareFile to:</b> <a href="https://nebraska.sharefile.com/r-r52e8166f202b4241af62af1fc0e8e5e4">https://nebraska.sharefile.com/r-r52e8166f202b4241af62af1fc0e8e5e4</a>	<del>October 8<sup>th</sup>, 2021</del> <del>2:00 PM</del> <del>Central Time</del>  <b>October 29<sup>th</sup>, 2021</b> <b>2:00 PM</b> <b>Central Time</b>
9.	Post "Notification of Intent to Award" to Internet at: <a href="http://das.nebraska.gov/materiel/purchasing.html">http://das.nebraska.gov/materiel/purchasing.html</a>	TBD
10.	Contract award	TBD

**This Addendum will become part of the proposal and should be acknowledged with the ITB.**

## ADDENDUM FOUR

### REVISION OF SECTION VI TECHNICAL SPECIFICATIONS

Date: September 17<sup>th</sup>, 2021

To: All Bidders

From: Rob Taylor, Procurement Officer  
AS Materiel Purchasing

RE: Addendum for ITB 6581 OF to be opened October 29<sup>th</sup>, 2021 at 2:00 p.m. Central

#### 1. Section VI Technical Specifications

Section VI, LL. HYDRAULIC SYSTEM is now removed in its entirety and replaced with the following.

#### LL. HYDRAULIC SYSTEM (Revised)

YES	NO	NO & PROVIDE ALTERNATIVE	
			1. The truck hydraulic pump shall be directly driven via a Spicer Number 1350 driveshaft connected to an OEM supplied PTO drive flange mounted on the engine front crankshaft dampener.
			2. Driveshaft shall pass under or through the engine radiator; under if possible.
			A. Drive flange attachment bolts and the hydraulic pump shaft set screw shall be safety wired.
			B. The driveline grease zerks shall be easily serviced.
			C. A heavy duty PTO shield is required from pump to front of chassis, which shall be attached to snow plow hitch or be a part thereof.
			3. The truck hydraulic pump shall be a minimum 8.75 cubic inch (145cc) variable displacement load-sense designed for continuous operation. The pump shall be a Parker P2145 or equivalent. Indicate brand & model supplying: _____
			A. The hydraulic pump shall be capable of producing a nominal 60 GPM flow at 1,800 engine RPM with a minimum 3,000 PSI operation pressure.
			4. Hydraulic system pressure will be set to operate at 2500 p.s.i.
			5. Hydraulic pump outlet port shall have an electronically operated valve to be operated by low hydraulic oil sensor. Valve will close when hydraulic oil is low.
			6. ½ inch hydraulic hoses from hydraulic stack valve to the front of the snow plow hitch for raise-lower and plow angle functions.
			A. Hoses to be rigidly mounted with ISO 16028 flat face interchange couplings. Couplers (one male and one female) placed so as not to interfere with plow hitch or plow function.
			1. Example of couplers:  Faster FFH0812NPT/Faster FFH0812NPTM (FPQ Premier) Parker FEM-501-8FP-ZP/Parker FEM-502-8FP-ZJ (XTR) Stucchi Part #2317188/2317189 (Z plated).
			2. Couplers to meet ISO 9227 standards to a minimum of 400 hours salt spray test.
			B. Hoses with one of the above listed couplers (one male and one female) shall be installed to plow cylinder.
			C. Plow up-down couplers to be mounted on plow hitch on passenger's side of truck. Plow angle couplers to be mounted on plow hitch on driver's side of truck.

			<b>D.</b> Plow angle circuit will have pressure relief valve. To be mounted inside frame rail near hitch.
			<b>E.</b> Only steel wire braided hoses are acceptable.
			<b>F.</b> Hydraulic oil to be multi-purpose, all season type. Please state ISO grade furnished: _____
			<b>7.</b> The hydraulic control valve(s) to be a stack valve type load independent proportional valve which is closed center, load sensing and pressure compensated to control three (3) functions simultaneously. A valve assembly utilizing a modular manifold with individual valve sections would also be acceptable. The control center console shall be floor mounted.
			<b>A.</b> The valve is to be controlled by electrical proportional actuation.
			<b>B.</b> Each valve section shall be equipped with adjustable trim control, flow control, spool stroke limiters or other means to control oil flow for each function independently.
			<b>C.</b> Valve is to be arranged as follows:
			1. Closed center inlet with relief.
			2. Hoist = 4 way, 26 gpm, 500 psi down port relief
			3. Plow lift = 4 way, 10 gpm
			4. Plow angle = 4 way, 10 gpm
			5. Wing toe = 4 way, 10 gpm, 500 psi down port relief (if required).
			6. Wing heel = 4 way, 10 gpm, 500 psi down port relief, 2000 psi up port relief (if required).
			7. Auger = 4 way, 17 gpm motor spool or cartridge valve.
			8. Spinner = 3 way, 10 gpm motor spool or cartridge valve.
			9. Prewet = 3 way, 6 gpm motor spool or cartridge valve.
			10. Tow plow steering = 4 way 10gpm
			11. Tow plow raise/lower = 3 way 10 gpm
			12. Trailer spreader = 4 way 15 gpm motor spool
			13. Trailer spinner = 1 way 10 gpm motor spool
			14. Trailer pre wet = 4 way 6 gpm motor spool
			15. Endcover
			<b>D.</b> Hydraulic control valve to be mounted behind cab a weatherproof enclosure with hydraulic oil tank. Location and hose routing to be reviewed during pilot inspection.
			<b>E.</b> Pressure and return hoses for anti-ice, pre-wet, spreader auger and spinner shall be routed from stack valve to rear of dump at lower horizontal rib 1/2" flat face couplers as previously stated shall be used. Function shall have individual pressure and return couplers. Two function/four couplers per side.
			<b>8.</b> The control center shall be a full proportional control of all hydraulic functions, spreader control functions with one single joystick or multiple joysticks to be located in the integral armrest. The control center with integral armrest shall be floor mounted.
			<b>A.</b> A drawing of proposed design must be submitted with bid packet. Drawings to include switch locations.
			<b>B.</b> Control of hydraulic functions with a fully proportional joystick(s) is to be located in the armrest. The armrest should be height adjustable and swing to left and right
			<b>C.</b> Joystick operation is described as follows:
			1. Shall operate proportionally and shall have the ability to run

			three (3) functions simultaneously.
			2. Hoist function: with operator activated safety lock.
			3. Plow function: lift-forward/backwards axis
			4. Plow angle-left /right axis
			5. Wing function- dual axis with operator activated safety lock.
			6. Wing lift- forward/backward axis
			7. Wing heel- left/right axis
			8. Benching Wing rear slide forward/backward axis.
			D. Spreader control, harness and wiring to back of truck will be set up for granular pre-wet, anti-ice, and total liquid use even if functions are not utilized.
			E. Spreader control System shall be Force America brand, Model 6100 or Certified Power brand, Model XDS. Would also be accepted. State System to be provided:
			1. It shall be capable of controlling the application rates of granular, with pre-wetting agents, and/or anti-icing agents simultaneously or independently, regardless of vehicle speed.
			2. Hydraulic system must be capable of operating chassis spreader and trailer spreader simultaneously with working either truck blade raise or tow plow blade raise
			3. Control must be GPS compatible. The spreader controller shall provide a standard output of real-time streaming data including but not limited to: Ground speed, surface and air temperature, material selected, material application rate, lane(s) material being applied to and pre-wet rate.
			a. The output shall be in standard format such as ASCII through a standard 9 pin, USB or other connector that meet NDOT approval.
			b. The data shall be formatted so that 3 <sup>rd</sup> party devices can read informational data in real time. All hardware, software and information necessary for 3 <sup>rd</sup> party device to read the data output shall be if requested at no additional charge to NDOT.
			4. It must be possible to reprogram the controller by upgrading the software.
			5. The control shall be installed onto the control console, mounted onto the dash or other pre-approved area. Installation shall position the control so it is easy for the operator to see and reach.
			6. Anti-ice feature shall include a 3-lane selective lane switch box mounted in, under or near the console or through the soft keys of controller. Box shall have four (4) switches, the first to allow selection of either anti-ice or granular system, the remaining three (3) shall be lane selections switches, left, center and right.
			a. Anti-ice system shall adjust pump output to maintain selected rate as lanes are activated or deactivated.
			b. Anti-ice system to close valves to prevent gravitational flow of liquid when truck is stopped or 'pass' button is pushed.
			c. Anti-ice system to provide an audio alarm for insufficient application of liquid. Display shall show actual rate being applied.
			d. An electronic display capable of being reset to indicate gallons remaining in tank or gallons used since reset.
			7. Control shall allow up to a minimum of ten different preprogrammed application rates plus a manual override

			feature. It shall be capable of four granular products and tow liquid products. A blast feature shall be incorporated.
			<b>8.</b> Controller blast button shall immediately cause full hydraulic flow to the auger section, causing maximum spreader material output. The blast system shall be equipped with a timer. Blast feature shall also work with Anti-Ice function.
			<b>9.</b> Controller shall default to 'pass or stand by' upon startup of truck even if console master switch is 'on'. This will eliminate material being spread when truck starts to move in year or is started in shop bay.
			<b>10.</b> A data lock key shall be part of the controller to prevent data or programs from being changed or deleted without key access. Password program also acceptable.
			<b>11.</b> A key shall be provided for each controller.
			<b>12.</b> Granular rates may be selectively displayed in pounds-per-lane-mile or kilograms-per-kilometer. Liquid pre-wet rates may be selectively displayed in gallons-per-ton or liters-per-metric ton.
			<b>13.</b> Controller shall have a non-volatile memory to store all program and data when it is disconnected from a power source.
			<b>14.</b> A LCD color display, minimum of seven (7) inches diagonal shall provide the operator with instant access to:
			<b>a.</b> Total distance.
			<b>b.</b> Total granular applied.
			<b>c.</b> Total liquid applied.
			<b>d.</b> Vehicle speed.
			<b>e.</b> Distance traveled.
			<b>f.</b> Low oil indicator.
			<b>g.</b> Body up indicator.
			<b>15.</b> All spreader control harnessing shall meet ISO IP68 and NEMA 6 standards. The connectors should be die cast E-coated, and be designed to have NO corrosion after 500 hours in a 35C salt spray. Each should have three sealing points (1) the lock ring itself, (2) a raised portion of the molded plastic around each pin, and (3) a Viton O-ring that seals the whole connector. Wiring to be equivalent to Daniel Woodhead, Brad Harrison electrical connectors and wiring.
			<b>9.</b> Switch panel to be Wired-Rite System Inc., Touchguard or Force America brands. Switches will have built-in bus bar connecting, silk screen backlit function indicators and magnetic automatic reset internal circuit breakers. Wiring shall include adequate slack to allow entire panel to be easily removed for service or replacement
			<b>A.</b> Main 12 volt battery feed into truck cab control box shall be protected by an 80 amp manual resetting waterproof circuit breaker (Wired Rite DB-80R or equivalent) installed close to the battery enclosure installed on the truck cab fire wall or within battery cover enclosure.
			<b>B.</b> The power feed line to the 80 amp breaker shall be a minimum of 4-gauge fine strand copper.
			<b>C.</b> The positive/negative wires into the cab from the breaker and truck frame ground shall be 4-gauge.
			<b>D.</b> Switch circuits will be either a battery or ignition type. Battery circuits shall be always hot. Ignition circuits will receive power through a Bosch model 0332002150 75 amp relay when the ignition switch is in both the accessory or run positions.
			<b>E.</b> The switches and lamps shall be labeled and function as follows: Right to left.

			<p>1. Plow/Truck Lights, (if OEM chassis supplied this is to be changed to an auxiliary switch SPST off/on) Battery DPDT, 2 position, ON/ON</p>
			<p>2. Cab/Hood Plow Lights Battery DPDT, 2 position ON/ON</p>
			<p>3. Amber /Blue strobe light Switch Ignition SPST, ON/OFF</p>
			<p>4. Clear /White strobe light Switch Ignition SPST, ON/OFF</p>
			<p>5. Wing light Switch Battery SPST, ON/OFF</p>
			<p>6. Spreader switch Battery SPST, ON/OFF</p>
			<p>7. Auxiliary switch Ignition SPST, ON/OFF</p>
			<p>8. Auxiliary Switch Ignition SPST ON/OFF</p>
			<p>9. Winter/Summer DPDT, 2 position, ON/ON</p>
			<p>F. Trailer warning lights switches connected to six pin trailer plug</p> <p>1. Rear beacon/strobe lights Battery SPST ON/OFF</p> <p>2. Wing light battery SPST ON/OFF</p>
			<p>G. A guarded/protected switch is also required to allow temporary over ride of low hydraulic oil shut down solenoid. This will allow operator to possibly operate any function to allow unit to be moved off roadway.</p>
			<p>H. The body up indicator lamp shall function as a dump body height warning system. In both the winter and summer mode, it shall illuminate whenever the body is raised.</p>
			<p>1. In addition, in the winter mode, working through an adjustable angle mercury switch, this system shall also include a flasher and audible alarm that will engage when the body attains the pre-set height adjustment of the mercury switch.</p>
			<p>2. Alarm must be loud enough to be heard over any truck noise.</p>
			<p>I. The Winter/Summer switch shall control power to the dump body height warning circuit. In the winter mode it will power the height warning feature of the dump body up lamp circuit causing it to function as designed. In the summer mode, it will not allow power to the dump height warning circuit.</p>
			<p>J. Switch panel to be located on the armrest portion of the control console and not interfere with the operation of the joystick.</p>
			<p>10. Hydraulic reservoir to be minimum 50 gallon oil capacity with five gallon expansion space for total 55 gallons.</p>
			<p>A. Reservoir to be sturdily mounted, and complete with suction strainer return filter and adequate shut-off valves for servicing.</p>
			<p>B. Return filter shall have a 10 micron rating. Filter shall be interchangeable with such filters as Donaldson P550388, Wix 51759, or Baldwin TB287-10. Please state filter to be provided:</p>
			<p>C. Suction strainer shall be 100 mesh with 5 PSI relief valve.</p>
			<p>D. A gate-type or ball valve shut-off valve, of at least the size of the suction line, is required between the reservoir and the suction line itself.</p>
			<p>11. Reservoir tank shall be mounted between the cab and body within the confines of 12 inch channel upright for cab shield.</p>

			<b>A.</b> The 7 gauge steel reservoir will be 12 inches wide.
			<b>B.</b> The approximate height will be 32 inches and approximate width of 33.5 inches.
			<b>1.</b> The reservoir must be of such height to allow visibility through rear cab window and to accommodate other chassis/body requirements.
			<b>C.</b> Reservoir will have a 45 to 70 degree filler pipe. Filler pipe will extend a minimum of three (3) inches through upright.
			<b>1.</b> Filler neck shall be removable from top of tank.
			<b>D.</b> A sight gauge with Fahrenheit temperature scale for checking proper oil level shall be furnished.
			<b>1.</b> Sight gauge location shall be on same side of reservoir as filler tube.
			<b>E.</b> A hydraulic oil low level alarm or indicator light is required.
			<b>1.</b> Alarm or light to be mounted in the cab.
			<b>12.</b> Bottom rear of tank on each side will have flat steel plates welded to back of tank with holes for bolting to upright flange.
			<b>A.</b> Upper part of tank will have ¼-inch x 6-inch flat plate welded to center of tank with holes for bolting to angle iron cross member between uprights. Bolts to be Grade 8.
			<b>B.</b> Tank shall be mounted so as to have adequate clearance from chassis components and so that it can be conveniently removed without moving the twelve inch uprights that secure the tank.
			<b>13.</b> The filter will be mounted on the same side of tank as filler tube.
			<b>A.</b> Reservoir will have a 1-inch magnetic drain plug and baffle(s) as needed.
			<b>B.</b> All components of hydraulic system shall be of size that will not restrict flow and withstand a minimum working pressure of 2,500 PSI.
			<b>14.</b> Vendor will minimize the number of critical rub points for hydraulic hoses, where critical rub points exist; they shall be wrapped with spiral metal or adequate rubber wrap.
			<b>15.</b> System shall permit the dump body to be raised or lowered while vehicle is traveling at highway speeds up to 35 MPH as well as when vehicle is not moving.
			<b>A.</b> Partially or fully raised box shall not creep up or down when vehicle is not moving or when hydraulic valve has been returned to neutral position and vehicle is traveling at 35 MPH or less.
			<b>16.</b> Hydraulic hook up for TowPlow <b>A.</b> Coupler stack to be located rear passage side of RDS body. Couplers to be ISO interchange .  <b>B.</b> II Faster 3P508G-4-12G-MC/Faster 2P508G-4-12G-FC
			<b>17.</b> Hydraulic circuit for steering and moldboard lift shall have pressure relief valve also mounted at rear passage side of RDS body.
			<b>18.</b> Detailed literature and manufacturer's specification and date sheets on PTO, Joystick Control, Spreader control crankshaft drive, hydraulic pump, valves, filters and flexible cable control system will be provided with bid. NO BID WILL BE CONSIDERED WITHOUT THE INCLUSION OF THIS INFORMATION NECESSARY TO EVALUATE THE BID.
			<b>19.</b> Hydraulic/spreader system training and support shall be provided by company representative.
			<b>A.</b> Training for operators and mechanics shall be provided by spreader control/hydraulic system representative.
			<b>1.</b> Training shall be done at any of the units, assigned locations and/or district within the State of Nebraska.

			<p>2. Training session shall be a minimum of four (4) hours for operators. An additional four (4) hours of training shall be provided to mechanics for diagnostic procedures and repair of controller system.</p>
			<p>3. Training shall include basic operation, calibration procedures, and basic trouble shooting. Training to be required and provided annually for each NDOT District.</p>
			<p><b>B.</b> Technical support shall be provided for systems.</p>
			<p>1. Vendor shall make a representative available to travel within the State of Nebraska and assist mechanic with system failures.</p>
			<p>2. Vendor representative shall travel to any of the units assigned location to make repairs during warranty.</p>
			<p><b>20.</b> The Hydraulic/Spreader control system shall be free of RFI emissions.</p>
			<p><b>A.</b> The hydraulic/spreader control system and/or installed components and equipment shall be compatible with use of NDOT mobile and/or two-way communication devices. Main communication radio operates in low band range of 47 MHz to 48 MHz, but all frequencies apply including low band, high band, UHF and VHF.</p>
			<p><b>B.</b> The hydraulic/spreader control system and/or installed components and equipment shall be manufactured to meet all current SAE and/or ISO Standard applicable and/or relevant to Electromagnetic Compatibility</p>
			<p><b>C.</b> NDOT will conduct testing of radio/two-way when installed in chassis. NDOT will notify vendor if normal operational parameters are not met due to degradation of signals caused by electromagnetic emissions from control system and/or installed components and equipment. Vendor shall be required to work with NDOT personnel to reduce interference level to a point acceptable to NDOT normal radio operation parameters. Vendor shall have 30 days to resolve RFI issue.</p>
			<p><b>D.</b> Vendor and/or manufacturer will be responsible for any and all cost to replace and/or modify any parts found to cause radio frequency interference. If NDOT and vendor cannot resolve source of RFI, the unit will sent to an independent accredited lab for testing to ensure SAE and/or ISO Standards compliance. Testing shall be done to SAE and/or ISO Standard which were current at time of bid. Should the unit fail testing at the accredited lab, the vendor shall be responsible for all cost incurred for testing.</p>
			<p><b>E.</b> If after testing by NDOT and/or accredited lab, the vendor is unable or unwilling to incur cost and correct the RFI issue to the satisfaction of NDOT, ALL ORDERS AND CORRESPONDING CONTRACT WILL BE CANCELED.</p>
<p><b>NOTES/COMMENTS:</b></p>			

**This Addendum will become part of the proposal and should be acknowledged with the ITB.**



## ADDENDUM FIVE, QUESTIONS AND ANSWERS FOR ITB 6581 OF

Date: October 01, 2021

To: All Bidders

From: Robert Taylor, Buyer  
AS Materiel State Purchasing Bureau

RE: Addendum for Invitation to Bid 6581 OF to be opened October 29, 2021 at 2:00 P.M. Central Time

### ITB

Following are the changes made to the above mentioned ITB. The changes are to be considered as part of the Invitation to Bid. It is the Bidder's responsibility to check the State Purchasing Bureau website for all addenda or amendments.

<u>Question Number</u>	<u>ITB Section Reference</u>	<u>ITB Page Number</u>	<u>Change</u>	<u>State Response</u>
1			How is the State going to deal with extended leadtimes and orderboards and annual price increases?	The State will work with the awarded Vendor on production lead-times. Price increases procedure is in Section II of the ITB. (terms and conditions)
2			Will the State accept a Volvo I Shift in lieu of the Allison 4000?	Bid as per specification
3			Will the State give any cost benefit if a stainless steel fuel tank is bid?	If Stainless steel is available from OEM, This will be a consideration on bid.
4		38	Is the 5.5-6.0 cubic inch pump what is desired or the bigger 8.75? OR Both?	Section LL. line 3. Should read: The truck hydraulic pump shall be a minimum 8.75 cubic inch (145cc) variable displacement load-sense designed for continuous operation. The pump shall be a Parker P2145 or equivalent. Indicate brand & model supplying:  _____
5		38	Do we quote the 5.5-6.0 with the RDS valve on this bigger chassis and option the Tow Plow options?	See question 4

6		38	Do you want the RDS valve quoted with an adder for the TP sections on this Chassis?	No, This is included in the Truck bid.
7			Does the 3-joystick package run the Hoist, Plow, Tow plow OR Hoist, Plow, Wing with a Tow plow delete?	Hoist, Plow, Wing. No tow plow delete.
8			Does the State want a 3-joystick package AND a 5-joystick package submitted in Lieu of the single joystick?	5 Joystick Clarification will be in the Hydraulics addendum
9			Do you want an option for a hydraulic shaker or vibrator? If so, how do you want it powered? Off the hydraulic valve, separate solenoid valve?	Not on the RDS body
10			Would it be possible to move the opening date for these Contracts out a couple of weeks, it will be almost impossible to get body quotes from venders in this short of time frame as they have to get pricing from several suppliers to finish their final quote back to us for completion of total bids, and because there are three separate bid all due about the same time it would be very helpful to extend the opening date.	Yes, Please see Addendum Three, Revised Schedule of Events
11			Will you delete on Page 5 item P, Best and Final Offer paragraph or state that it's N/A to this type of commodity bid?	6581 OF is hereby amended to remove Best and Final Offer paragraph from Page 5, section P of the ITB.

12			<p>Will you add line item for single axle cab &amp; chassis only option?</p> <p>We have several Cities and Counties that would like to see option for single axle truck.</p>	<p>6581 OF is amended to include lines 25 &amp; 26 to accommodate single axle cab &amp; chassis only options.</p>
----	--	--	--	---

This addendum will become part of the ITB and should be acknowledged with the Invitation to Bid



# Modular Spool Valve Systems

HYDRAULICS

CONTROLS

REPORTING

## Consistent operations from modular hydraulic spool valve systems

*Dependability and consistency is what you can expect from Certified Power Solutions modular hydraulic spool valve systems. Available in a variety of systems from respected brands such as Danfoss and Prince, our hydraulic spool valve systems offer wide-ranging flow capacity and pressure ratings, and compatibility with manual, pneumatic and electronic plow and spreader controls.*

### MODULAR SPOOL VALVE SYSTEMS

- Pre-compensated, proportional, load independent
- Available in flow ratings from 5–38 GPM, laminar flow design spools
- Spools are field changeable without disassembling the module
- Maximum pressure of 5075 psi
- Manual (cables), pneumatic (air) or electronic (PWM) controls
- Danfoss PVG 32 and PVG 32 hybrid models
- V20 and Hybrid V20 models
- ISO 9001:2000 certified manufacturing

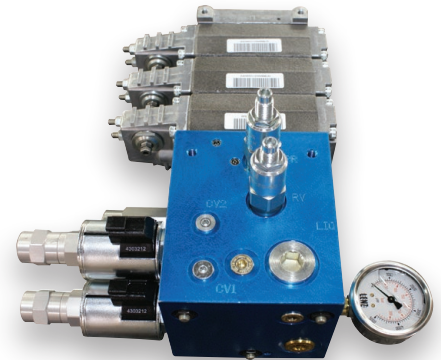

PVG 32 hybrid

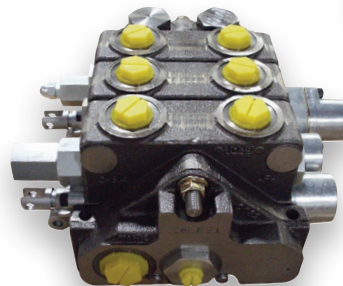

V20



PVG 32 electric actuation

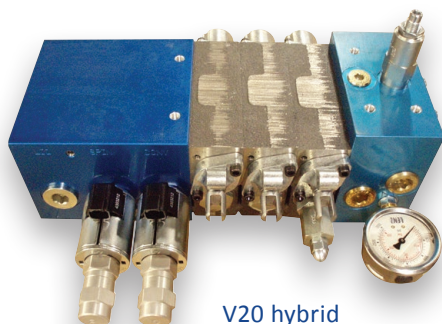

V20 hybrid



PVG 32 air actuation

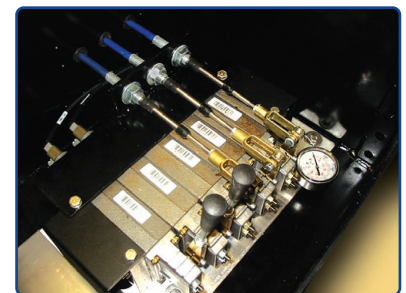

PVG 32 manual actuation



[certifiedpowersolutions.com](http://certifiedpowersolutions.com)



Minneapolis, MN  
763-493-9380  
[cps-mn@certifiedpower.com](mailto:cps-mn@certifiedpower.com)

Chicago, IL  
847-573-3800  
[cps-il@certifiedpower.com](mailto:cps-il@certifiedpower.com)

Des Moines, IA  
515-244-7411  
[cps-ia@certifiedpower.com](mailto:cps-ia@certifiedpower.com)

St. Louis, MO  
314-344-3300  
[cps-mo@certifiedpower.com](mailto:cps-mo@certifiedpower.com)

Toledo, OH  
419-873-7411  
[cps-oh@certifiedpower.com](mailto:cps-oh@certifiedpower.com)



# SpreadSmart Rx™

Electronic spreader control systems

HYDRAULICS • CONTROLS • REPORTING

## Precision controls for powerful spreader performance

When it comes to electronic spreader controls, your winter maintenance vehicles require accuracy, power and performance. Offering sophisticated technology such as temperature-controlled spreading, integrated load and rate management and Wi-Fi data transfer compatibility, the SpreadSmart Rx™ provides industry-leading precision and easy operation. What's more, the SpreadSmart Rx is designed with AVL ready hardware providing capacity to advance your system technology as needed.

### SPREADSMART RX

- The most versatile spreader control in the industry
- 4 channels, closed loop, ground-speed oriented, granular, pre-wet, anti-ice control
- Optional 8 channels, closed loop, ground-speed oriented, granular, pre-wet, anti-ice control for tow plow applications
- Multiplex/CAN bus communication
- Temperature-triggered spreading control
- Proportional closed-loop gate control
- On-board diagnostics tools
- AVL ready



LCD display



7" color display



10" dual camera touch display front view



10" dual camera touch display backup view



Toggle keypad



Membrane keypad



SpreadSmart Rx CPU





# SpreadSmart Rx™

## Electronic spreader control systems

### PRODUCT SUMMARY

- 4 channel, ground speed oriented, open/closed-loop controller with data logging and optional Wi-Fi data transfer
- Prescription spreading using live road temperature data and/or by programmed rates

### PRODUCT APPLICATION

- Auger/conveyor, spinner, pre-wet and anti-icing (3 booms x 2 tiers)

### SPREADING PRECISION

- Industry-leading spreading precision in closed-loop and open-loop operation

### SINGLE OR MULTIPLE LANE WIDTH SETTINGS

- Area spreading in lbs/gal per lane mile (auto adjusts rate for > 1 lane spreading)
- Linear spreading in lbs/gal per mile (operator controls spinner)

### SPREADING RATE DEFINITIONS

- Customized application rates for granular, pre-wet and anti-icing
- 10 types for granular, 10 types for pre-wet, 10 types for anti-ice

### TEMPERATURE-LINKED SPREADING PRESCRIPTIONS

- Temp Response™ integrates road temperature sensor, controlling granular and liquid application automatically

### LOAD AND RATE CALCULATOR AND MATERIAL REMAINING

- Calculates granular and liquid requirements for each route (miles) and automatically sets system rates per that calculation
- Auto mode then includes indication for miles, tons, gallons and % remaining

### PROPORTIONAL GATE CONTROL

- Control of optional closed-loop hydraulic gate height and conveyor speed

### ENGLISH AND METRIC UNITS STANDARD

- System operates in English or metric units

### DATA LOGGING BY MATERIAL NAME FOR BILLING

- Select specific application rate definitions and related data logging for specific purpose (i.e., state vs. county vs. city roads)

### STORM AND SEASON TOTALS

- System logs application amounts by rate definition for the storm and the season (storm total is operator resettable)

### AVL READY

- Compatible with many brands of radio and cell phone AVL systems

### SYSTEM SET-UP WIZARD

- On-screen, step-by-step programming and troubleshooting

### ON-SCREEN DIAGNOSTICS AND HELP MENU

- System diagnostics available on screen for settings, software, memory, GPS, distance meter
- Easy-to-follow instructions for use of all parameters shown in "help menu"

### BLAST AND PASS (PAUSE)

- Blast is programmable (on/off, timed, momentary)
- Pass (pause spreading temporarily)
- Remote blast and remote pass accessible

### SIGNAL COMMUNICATIONS

- Multiple frequency settings for valve compatibility
- Multiplex/CAN bus communication

### POWER SAFETY

- Power Safe™ signals prevent random grounds powering any hydraulics system attached (auger, spinner, conveyor, etc.)
- Channel Safe™ detects and protects against open or short circuits on hydraulic drive channels
- Minimum: 11 Volts DC; Maximum 15 Volts DC

### SYSTEM DISPLAY OPTIONS

- White/blue LCD: 8 lines, 40 characters/line
- 7" color TFT: 16 lines, 40 characters/line
- Optional 7" TFT touch-screen control

### SYSTEM MOUNTING

- Seat or pedestal mount
- Standalone or dash mount for display

### WARNING INDICATORS

- Visible (on display) and audible (buzzer)

### OPTIONAL EQUIPMENT

- GPS antenna
- Road and air temperature sensor
- Drive by Download™ system
- Gate height sensor, gate height position, hopper level



[certifiedpowersolutions.com](http://certifiedpowersolutions.com)



Minneapolis, MN  
763-493-9380  
[cps-mn@certifiedpower.com](mailto:cps-mn@certifiedpower.com)

Chicago, IL  
847-573-3800  
[cps-il@certifiedpower.com](mailto:cps-il@certifiedpower.com)

Des Moines, IA  
515-244-7411  
[cps-ia@certifiedpower.com](mailto:cps-ia@certifiedpower.com)

St. Louis, MO  
314-344-3300  
[cps-mo@certifiedpower.com](mailto:cps-mo@certifiedpower.com)

Toledo, OH  
419-873-7411  
[cps-oh@certifiedpower.com](mailto:cps-oh@certifiedpower.com)

ENGINEERING  
TOMORROW



# Power and control for all your work function needs

Series 45 Open Circuit Axial Piston Pumps

**60+**

countries served  
by our global  
manufacturing  
facilities ensures  
market proximity



[powersolutions.danfoss.com](http://powersolutions.danfoss.com)



# Series 45

## Total customer experience

Danfoss Series 45 Open Circuit Axial Piston Pumps are designed to offer you innovative solutions for all of your vehicles' needs.

Expert system and product engineers are working every day to exceed your expectations. Fast response, product knowledge and industry experience give you an advantage over your competitors.

### Global product, local support

Expanding operations are consistently bringing your products closer to you. Series 45 has manufacturing locations in North America, Europe and Asia Pacific serving over 60 countries. Serving you as an industry leader in off-highway Open Circuit Piston Pump technology, Danfoss continues to provide successful applications on many major OEM vehicles spanning all market segments and regions. Our 'open-door' policy ensures superior customer service with globally-located experts just around the corner available to assist you.

### Reliability, performance, delivery

More than 50 years of industry experience verified by customer testing and field use, results in the industry-leading products like Series 45 Open Circuit Piston Pumps that OEM's in the agriculture, construction, road building, material handling, forestry and turf care industries rely on today.



Innovative manufacturing systems, and state-of-the-art testing and verification labs across the globe support our high expectations for quality resulting in the best, most reliable products for your machine.

### Innovation

With the Danfoss spirit of innovation and continuous improvement, Series 45 is working on the next generation of high efficiency open circuit solutions.

Looking ahead, you can continue to count on the high quality products and services you expect worldwide.

*The Series 45 family*





- **Global manufacturing serving over 60 countries**
- **Wide range of displacements, controls, pressures and configurations**
- **Simple system integration for off-the-shelf implementation**
- **Modular design allows for fast and flexible delivery**
- **Easy access to Danfoss product and system experts**



# Danfoss commitment to **continuous improvement**

By continuously improving functionality and design with your applications in mind, Series 45 maintains industry-leading performance levels to provide you with maximum efficiency and productivity. Danfoss product experts are consistently working

with customers to find new, innovative ways to improve the industry as a whole. By partnering with Danfoss and Series 45, you will find new, innovative solutions for your application needs to help differentiate your product in the market.

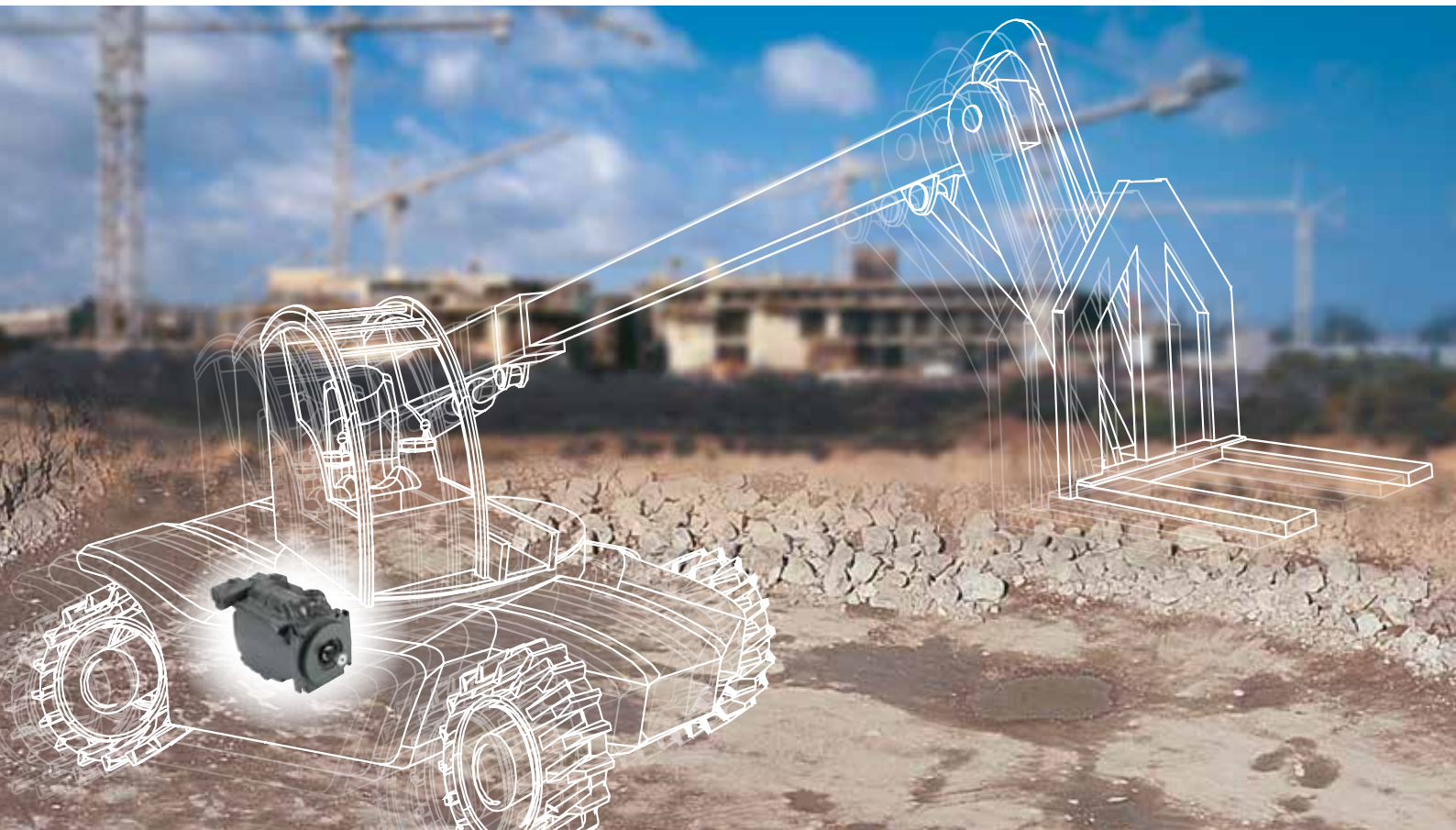

## **Industry leading functionality**

A complete line of industry standard pump interfaces along with highly responsive on-demand flow complements our extensive portfolio of control options.

## **Durability & quality commitment**

Housing in a one-piece rugged iron frame eliminates the need for gaskets, while high temperature shaft seals reduce the number of potential leak paths.

## **Operator comfort**

One-piece iron housing and valve plate design allows for superior sound deadening characteristics that offer a more comfortable experience for the operator and help meet industry regulations.



### Pump overview

Series 45 offers a full line of displacements and pressures that have been designed to fit your multiple application needs.

### L 25 C

Type code in the example below:

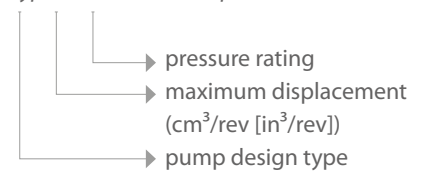

This chart shows how the displacements are arranged with respect to pressure rating

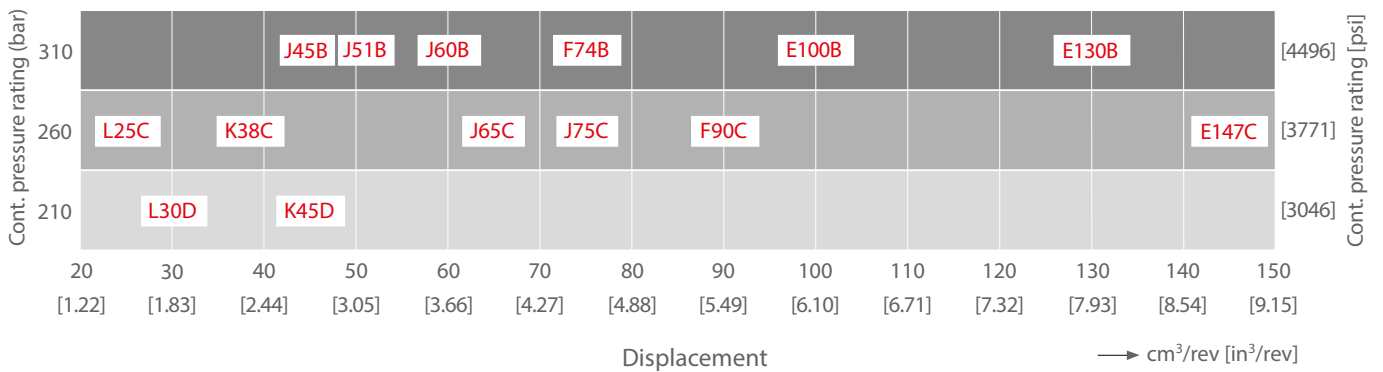

### Controllability

Fast responding pumps designed for use in a wide variety of applications utilize customizable hydro-mechanical and electric controls powered by Danfoss PLUS+1® solutions.

### Reduced downtime

Danfoss has product and system support experts in all regions around the globe ready to help you. These quick-responding experts will help you resolve any issues that arise.

### Reduced time-to-market

By offering compatibility with all Danfoss products, as well as PLUS+1 Compliance, Danfoss with the Series 45 is your strongest partner in mobile hydraulics.

# Applications, integrations and controls

## Pressure compensator

Maintains system pressure at or below the specified pressure setting. Ideal for applications such as on/off fan drives and constant force cylinders.

## Remote pressure

Allows multiple PC settings, for applications such modulating fan drives, and electronic load sense.

## Load sensing

Adjusts the system flow to maintain a constant margin pressure. Improves overall system efficiency by varying pressure and flow.

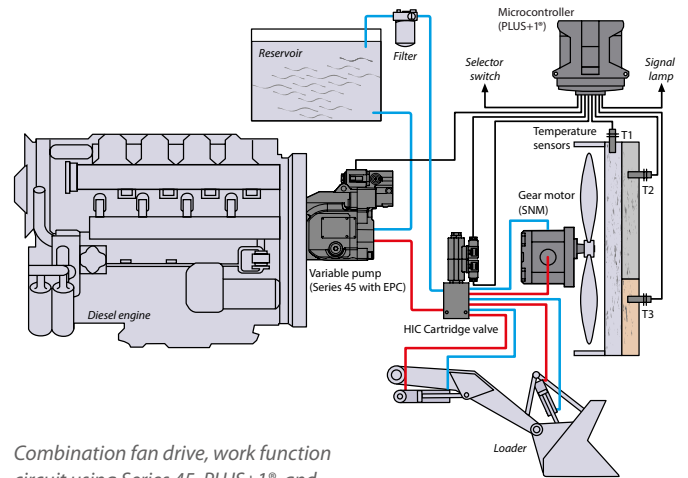

Combination fan drive, work function circuit using Series 45, PLUS+1®, and other Danfoss components



**Danfoss and the Series 45 offer a wide range of displacements and controls. The ability to integrate Series 45 with PVG and PLUS+1® solutions offers an infinite number of control combinations and gives you the ability to tune them to fit your specific needs.**

## Efficient, electric controls

### **PLUS+1® Compliance**

Optimizing systems around electronic controls is the future of mobile machinery. When combined, Series 45 and the PLUS+1 system allow for easy integration with other PLUS+1 Compliant Danfoss products, allowing you to quickly build customized applications while reducing the cost and development time normally associated with programming.

With electronic control, load-sensing and a flexible, modular design, PVG valves enable you to meet these challenges.

### **Electric on/off normally open and normally closed with pressure compensating**

Operates as a PC-type control with the ability to switch to low pressure standby. Ideal for unloading the hydraulic system during engine start up.

### **Electric on/off normally closed with pressure compensating and load sensing**

Operates as a PC/LS control with the ability to override the PC control to operate in low pressure standby. Ideal for unloading the hydraulic system during engine start up while maintaining an LS system.

### **Electronic proportional pressure control, normally closed and normally open**

Control operating pressure proportionally with an infinite range between low pressure standby and high pressure setting, ideal for modulating fan drives.



*Legend:  
Electronic Proportional Pressure Control (EPC),  
Pressure Compensating (PC), Load Sensing (LS)  
Normally Closed (NC), Normally Open (NO),*

## About Danfoss Power Solutions

**Danfoss Power Solutions** is a global manufacturer and supplier of high-quality hydraulic and electronic components. We specialize in providing state-of-the-art technology and solutions that excel in the harsh operating conditions of the mobile off-highway market. Building on our extensive applications expertise, we work closely with you to ensure exceptional performance for a broad range of off-highway vehicles. We help OEMs around the world speed up system development, reduce costs and bring vehicles to market faster.

Danfoss Power Solutions – your strongest partner in mobile hydraulics.

### Products we offer:

- Bent Axis Motors
- Closed Circuit Axial Piston Pumps and Motors
- Displays
- Electrohydraulic Power Steering
- Electrohydraulics
- Hydraulic Power Steering
- Integrated Systems
- Joysticks and Control Handles
- Microcontrollers and Software
- Open Circuit Axial Piston Pumps
- Orbital Motors
- PLUS+1® GUIDE
- Proportional Valves
- Sensors
- Steering
- Transit Mixer Drives

Wherever off-highway vehicles are at work, so is Danfoss Power Solutions. We offer you expert worldwide support for ensuring the best possible solutions for outstanding performance. And with an extensive network of Global Service Partners, we also provide you with comprehensive global service for all of our components.

Go to [www.powersolutions.danfoss.com](http://www.powersolutions.danfoss.com) for further product information.

### Danfoss Power Solutions (US) Company

2800 East 13th Street  
Ames, IA 50010, USA  
Phone: +1 515 239 6000

### Danfoss Power Solutions ApS

Nordborgvej 81  
DK-6430 Nordborg, Denmark  
Phone: +45 7488 2222

### Danfoss Power Solutions GmbH & Co. OHG

Krokamp 35  
D-24539 Neumünster, Germany  
Phone: +49 4321 871 0

### Danfoss Power Solutions Trading (Shanghai) Co. Ltd.

Building #22, No. 1000 Jin Hai Rd  
Jin Qiao, Pudong New District  
Shanghai, China 201206  
Phone: +86 21 3418 5200

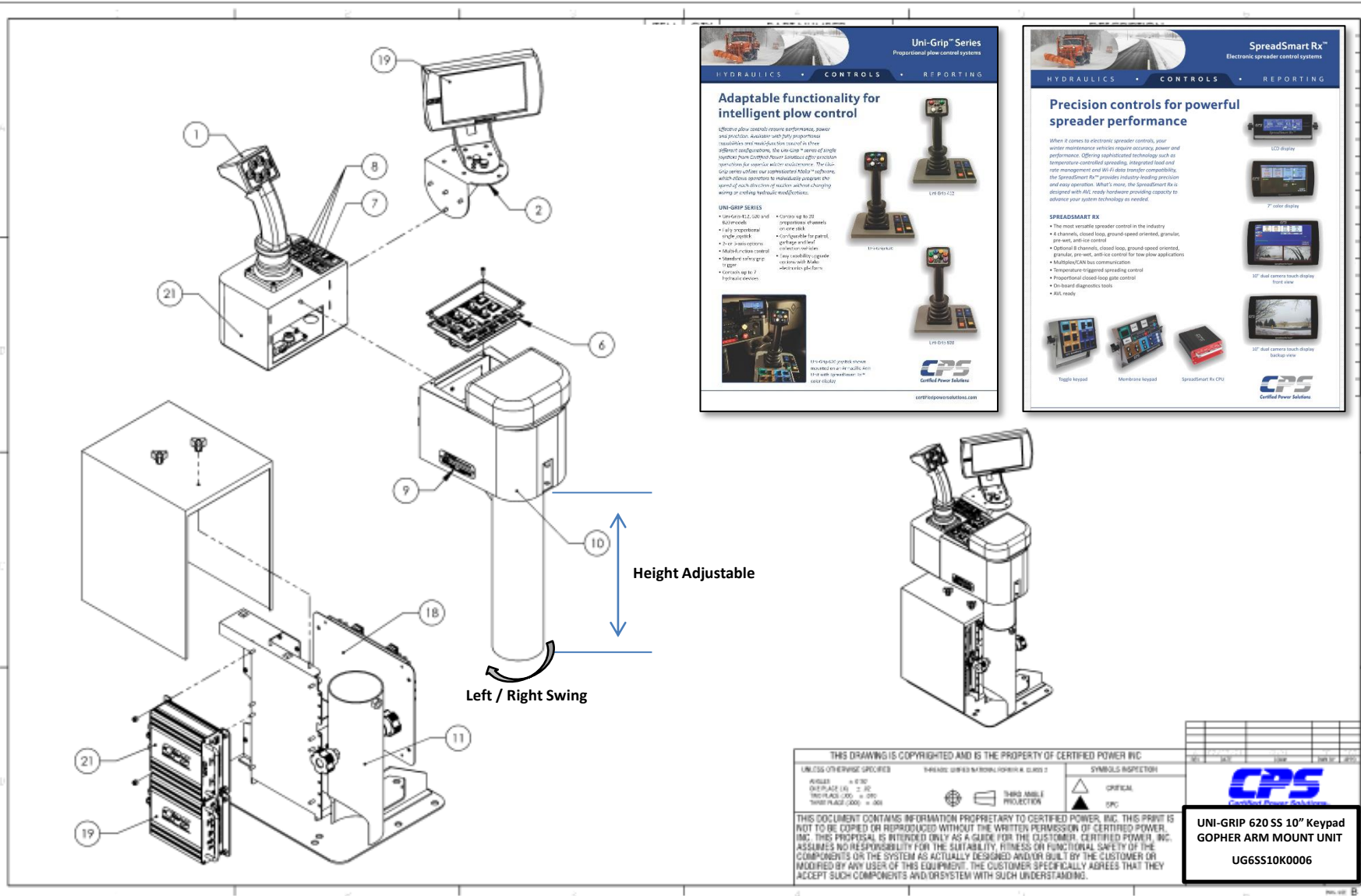

### Uni-Grip™ Series

Proportional plow control systems

HYDRAULICS • CONTROLS • REPORTING

#### Adaptable functionality for intelligent plow control

Efficient plow spreads ensure performance, power and precision. Accurate with 24/7 proportional capabilities and real-time data used in these critical applications, the Uni-Grip™ series of single systems from Certified Power Solutions offer precision operation for spreader and plow applications. The Uni-Grip series utilizes our sophisticated Motor™ software, which allows operators to maximize spreader efficiency of each division of machine without changing setup or making individual modifications.

**UNI-GRIP SERIES**

- Control up to 32 proportion channels on one stick
- Configurable for panel, joystick and foot control operation
- Easy enable/disable control with Keek™ electronic platform
- Control up to 7 hydraulic circuits
- Fully proportional
- 24/7 operation
- Multi-division control
- Standard safety grip trigger
- Control up to 7 hydraulic circuits

Uni-Grip 620 joystick shown mounted on the console with 10" cam spreader (10" cam 1000)

UNI-GRIP 620  
UNI-GRIP 620

CPS Certified Power Solutions  
cps@cpowersolutions.com

### SpreadSmart™ Rx

Electronic spreader control systems

HYDRAULICS • CONTROLS • REPORTING

#### Precision controls for powerful spreader performance

When it comes to electronic spreader controls, your water maintenance vehicles require accuracy, power and performance. Offering sophisticated technology such as temperature-controlled spreading, integrated load and rate management and Wi-Fi data transfer capability, the SpreadSmart Rx™ provides industry-leading precision and easy operation. What's more, the SpreadSmart Rx is designed with 40+ ready hardware providing capacity to advance your system technology as needed.

**SPREADSMART RX**

- The most versatile spreader control in the industry
- 4 channels, closed loop, ground speed oriented, granular, gravel, and ice control
- Optional 8 channels, closed loop, ground speed oriented, granular, gravel, and ice control for low speed applications
- Multiple CAN bus communication
- Temperature triggered spreading control
- Proportional closed loop rate control
- On-board diagnostics tools
- AEC ready

10" LCD display  
7" color display  
10" dual camera touch display front view  
10" dual camera touch display back view

Keypad keypad  
Membrane keypad  
SpreadSmart Rx (CPS)

CPS Certified Power Solutions

THIS DRAWING IS COPYRIGHTED AND IS THE PROPERTY OF CERTIFIED POWER INC

UNLESS OTHERWISE SPECIFIED: DIMENSIONS SHOWN IN PARENTHESIS ARE CLASS 2

SYMBOLS AND NOTATION: CRITICAL, SPC

THIS DOCUMENT CONTAINS INFORMATION PROPRIETARY TO CERTIFIED POWER, INC. THIS PRINT IS NOT TO BE COPIED OR REPRODUCED WITHOUT THE WRITTEN PERMISSION OF CERTIFIED POWER, INC. THIS PROPOSAL IS INTENDED ONLY AS A GUIDE FOR THE CUSTOMER. CERTIFIED POWER, INC. ASSUMES NO RESPONSIBILITY FOR THE SUITABILITY, FITNESS OR FUNCTIONAL SAFETY OF THE COMPONENTS OR THE SYSTEM AS ACTUALLY DESIGNED AND/OR BUILT BY THE CUSTOMER OR MODIFIED BY ANY USER OF THIS EQUIPMENT. THE CUSTOMER SPECIFICALLY AGREES THAT THEY ACCEPT SUCH COMPONENTS AND/OR SYSTEM WITH SUCH UNDERSTANDING.

**CPS**  
Certified Power Solutions

**UNI-GRIP 620 SS 10" Keypad  
GOPHER ARM MOUNT UNIT  
UG6SS10K0006**

NOTES:

1. ITEMS MARKED " " ARE SHIPPED LOOSE AS SALE ORDER LINE ITEMS

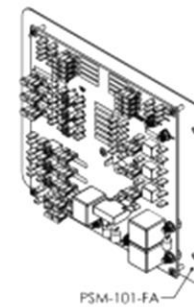
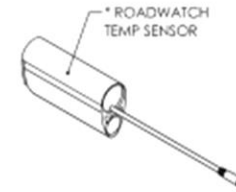
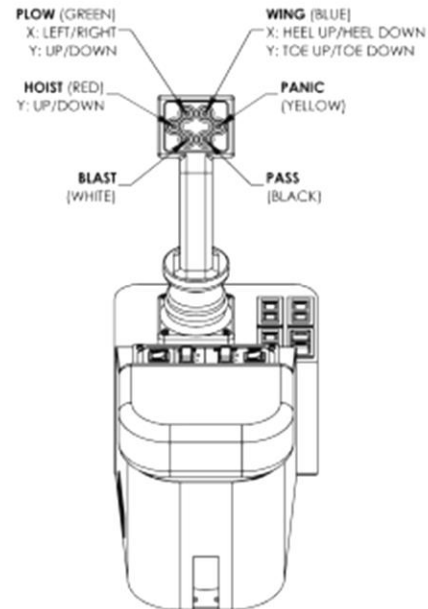
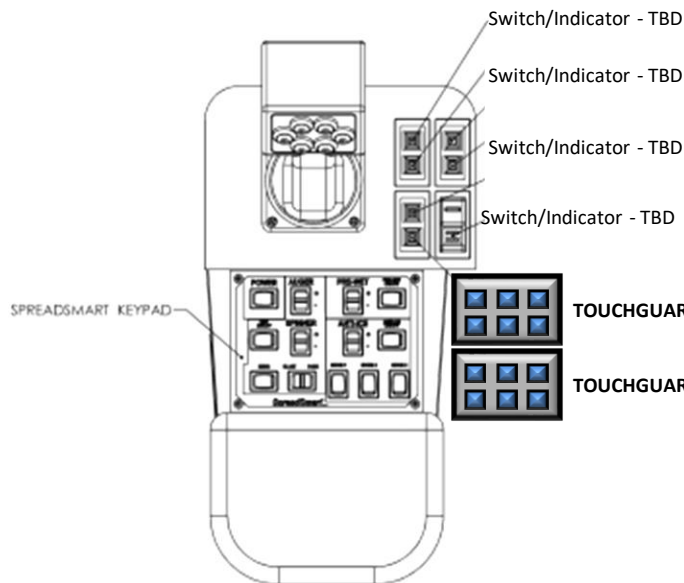

THIS DRAWING IS COPYRIGHTED AND IS THE PROPERTY OF CERTIFIED POWER INC. UNLESS OTHERWISE SPECIFIED. SCALE: DIMS BY DIMS, DIMS BY DIMS. SYMBOLS INSPECTOR: CH/PCB, SPC.

UNLESS OTHERWISE SPECIFIED: DIMS BY DIMS, DIMS BY DIMS. SYMBOLS INSPECTOR: CH/PCB, SPC.

THIS DOCUMENT CONTAINS INFORMATION PROPRIETARY TO CERTIFIED POWER, INC. THIS PRINT IS NOT TO BE COPIED OR REPRODUCED WITHOUT THE WRITTEN PERMISSION OF CERTIFIED POWER, INC. THIS PROPOSAL IS INTENDED ONLY AS A GUIDE FOR THE CUSTOMER. CERTIFIED POWER, INC. ASSUMES NO RESPONSIBILITY FOR THE SUITABILITY, FITNESS OR FUNCTIONAL SAFETY OF THE COMPONENTS OR THE SYSTEM AS ACTUALLY DESIGNED AND/OR BUILT BY THE CUSTOMER OR MODIFIED BY ANY USER OF THIS EQUIPMENT. THE CUSTOMER SPECIFICALLY AGREES THAT THEY ACCEPT SUCH COMPONENTS AND/OR SYSTEM WITH SUCH UNDERSTANDING.

REV	DATE	BY	CHK	APP

UNI-GRIP 620 SS 10" Keypad  
 GOPHER ARM MOUNT UNIT  
 UG6SS10K0006



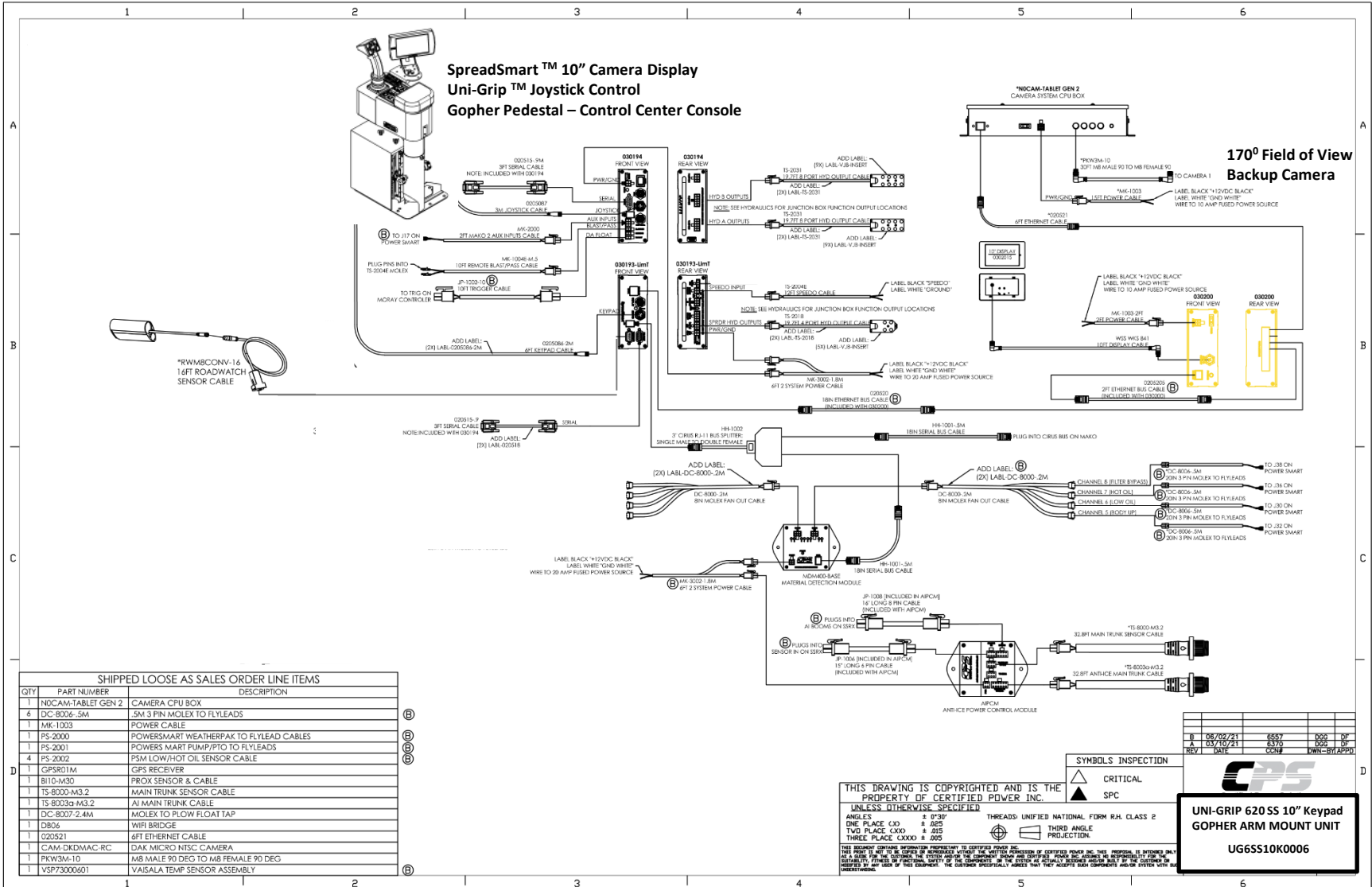

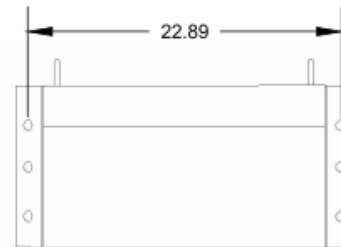
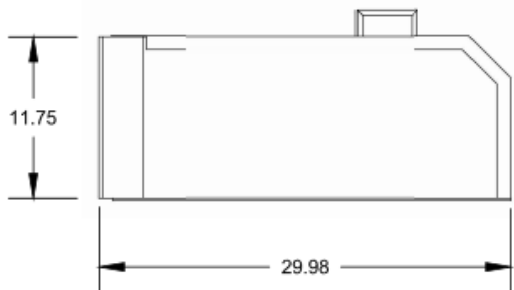
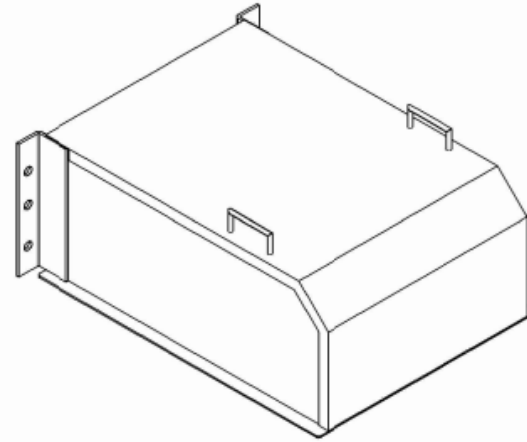
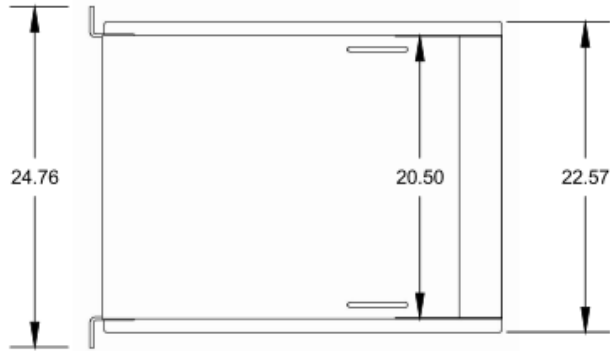

THIS DRAWING IS THE PROPERTY OF CIRUS CONTROLS.  
THIS IS TO BE CONSIDERED CONFIDENTIAL AND  
PROPRIETARY NO REPRODUCTION IN WHOLE OR PART  
WITH OUT PERMISSION IS ALLOWED.

**HYD100062M**

**CIRUS** PHONE: (763) 493-8380  
**CONTROLS LLC** FAX: (763) 493-9340  
 7165 BOONE AVE. N. SUITE 190  
 BROOKLYN PARK, MN 55428

PROJECT NUMBER: 14-024	SCALE: 1:10	11-12-2014 REV.
		SHT 1 OF 2



## Adaptable functionality for intelligent plow control

Effective plow controls require performance, power and precision. Available with fully proportional capabilities and multi-function control in three different configurations, the Uni-Grip™ series of single joysticks from Certified Cirus Control Systems offer precision operations for superior winter maintenance. The Uni-Grip series utilizes our sophisticated Mako™ software, which allows operators to individually program the speed of each direction of motion without changing wiring or making hydraulic modifications.

### UNI-GRIP SERIES

- Uni-Grip 412, 620 and 820 models
- Fully proportional single joystick
- 2- or 3-axis options
- Multi-function control
- Standard safety grip trigger
- Controls up to 7 hydraulic devices
- Control up to 20 proportional channels on one stick
- Configurable for patrol, garbage and leaf collection vehicles
- Easy capability upgrade options with Mako electronics platform



Uni-Grip 412



Uni-Grip 620



Uni-Grip 820



Uni-Grip 620 joystick shown mounted on an Armadillo Arm Unit with SpreadSmart Rx™ color display



# Uni-Grip™ Series

## Proportional plow control systems

### PRODUCT SUMMARY

- Single joystick for proportional control of hydraulic devices (e.g., hoist, plow, wing, blade)
- Utilizes Mako Trim™, a Windows® compatible program to set the speed of each direction of motion individually without wiring or hydraulic modifications

### PRODUCT APPLICATION

- Multiple vehicle types (patrol trucks for snow/ice, sanitation, leaf collection, etc.)
- Control of each hydraulic function independently

### DEVICE AND SIGNAL CAPACITY

- UG 412 - up to 3 devices; 12 independent PWM channels
- UG 620 - up to 5 devices; 20 independent PWM channels
- UG 820 - up to 7 devices; 20 independent PWM channels
- Frequency range from 40 – 450 Hz

### JOYSTICK BUTTONS

- UG 412 - 2 programmable buttons
- UG 620 - 4 programmable buttons
- UG 820 - 6 programmable buttons

### AXIS AND RANGE OF JOYSTICK MOTION

- UG 412 - 2 axes of joystick motion: X and Y
- UG 620 - 3 axes of joystick motion: X, Y and Z
- UG 820 - 3 axes of joystick motion: X, Y and Z
- 27 degrees of motion available in each axis

### JOYSTICK SIGNAL

- True Hall effect (Magnetic) joystick with no mechanical contacts

### JOYSTICK SELF TEST DIAGNOSTICS WITH CAN BUS

- Mako uses CAN bus for a self test of the joystick during each power cycle
- SafeStik™ automatically disables the axis if an axis fails during use
- Joystick diagnostics visible on LED, LCD or at valve body
- Channel Safe™ detects and protects against open or short circuits in hydraulic drive channels

### COMBO UP (PANIC) FUNCTION

- Momentary button trigger for parking of up to 6 devices

### FLOAT FUNCTIONS

- User settable float controls for plow, wing toe, wing heel and blade

### PLOW CONTROL INTERLOCKED FEATURES

- Hoist lock, hoist limit, plow, wing and blade lock (requires external sensor, key or switch)

### ELECTRONIC BACKPACK

- Mako multiplexed on CAN bus and Certified Cirus Control Systems bus

### SYSTEM CONTROLLER

- Mako Trim works on any Windows® 2000 (or newer) computer
- Field configurable buttons and function names

### DISPLAY TYPE

- UG 412 - LED indication mounted in joystick head
- UG 620 - graphic LCD (white/blue) or optional color TFT
- UG 820 - graphic LCD (white/blue) or optional color TFT

### SYSTEM MOUNTING

- Seat mounted or pedestal mounted

### WARNING INDICATORS

- Up to 8 labeled and colored indicators integrated into the joystick housing

### OPTIONAL EQUIPMENT

- Uni-Grip control of plow float and Moray™ system

### OPERATING TEMPERATURE RANGE

- Minimum: -20 degrees Celsius; maximum: 70 degrees Celsius

### POWER REQUIREMENTS

- Minimum: 11 Volts DC
- Maximum: 15 Volts DC
- Maximum: 10 Amps
- Internal fuse rated at 10 Amps



Minneapolis, MN  
763-493-9380

St. Louis, MO  
314-344-3300

Des Moines, IA  
515-244-7411

Chicago, IL  
847-573-3800

Toledo, OH  
419-873-7411

[www.certifiedcirus.com](http://www.certifiedcirus.com)

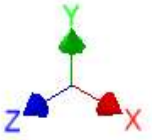
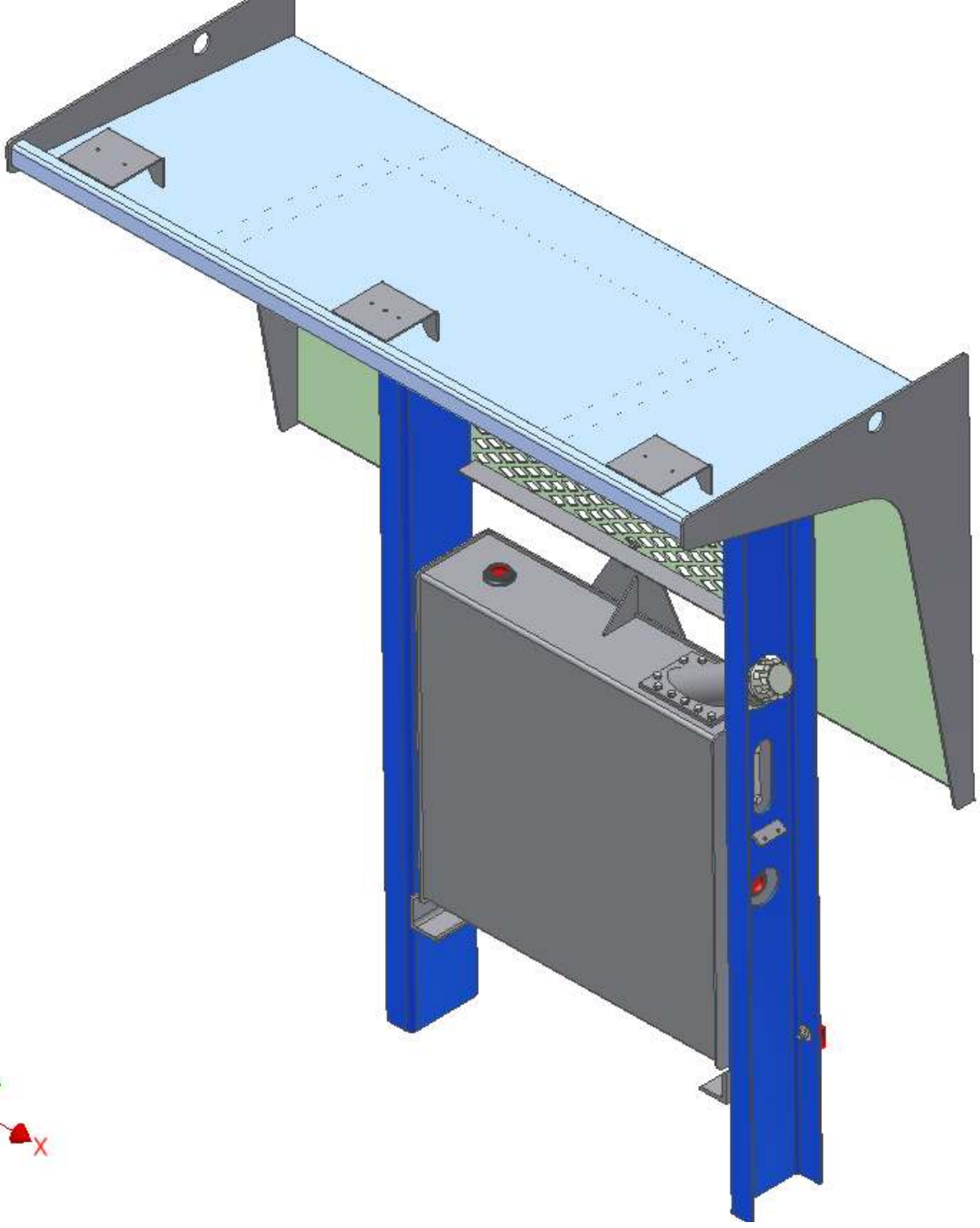

# Flange Yokes

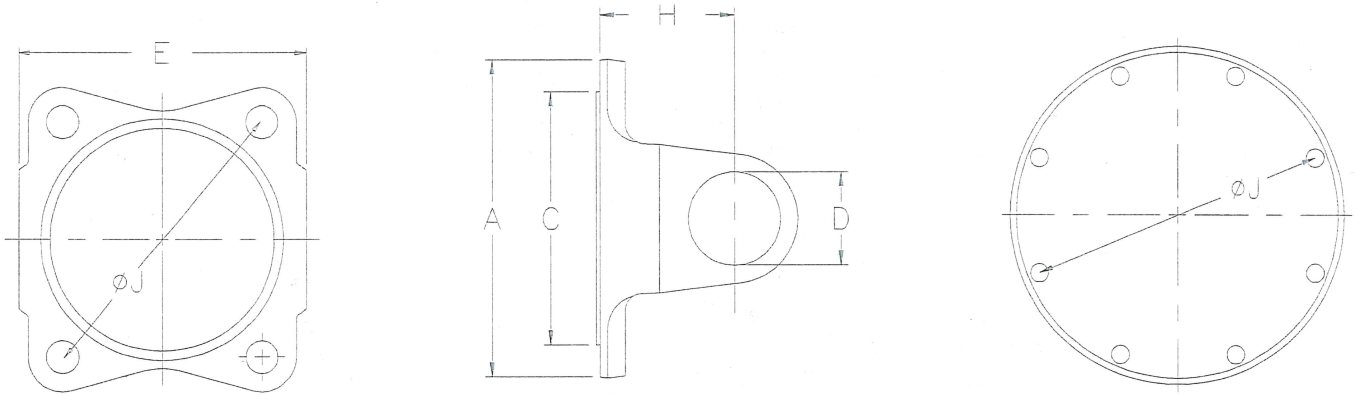

Series	E Distance Across Lugs	D Bearing Diameter	A Flange Swing Diameter	J Circle Diameter	Bolt Hole Diameter	No. Bolt Holes	C Pilot Diameter	H Flange Face to Centerline
1280	3.47"	1.06"	3.88"	3.12"	.38"	4	M-2.38"	1.38"
1310	3.47"	1.06"	3.88"	3.12"	.38"	4	M-2.38"	1.38"
1350	3.88"	1.19"	4.62"	3.75"	.44"	4	M-2.75"	1.56"
1410	4.44"	1.19"	4.69"	3.75"	.44"	4	M-2.75"	1.69"
1410	4.44"	1.19"	5.88"	4.75"	.50"	4	M-3.75"	2.00"
1480	4.44"	1.38"	5.88"	4.75"	.50"	4	M-3.75"	2.00"
1480	4.44"	1.38"	5.88"	4.75"	.50"	4	M-3.75"	1.50"
1550	5.25"	1.38"	5.88"	4.75"	.50"	4	M-3.75"	2.00"
1550	5.25"	1.38"	5.88"	4.75"	.50"	4	M-3.75"	1.50"
1550	5.25"	1.38"	6.88"	6.12"	.38"	8	M-6.62"	2.00"
1550	5.25"	1.38"	6.88"	6.12"	.38"	8	M-5.31"	2.00"
1610	5.31"	1.88"	6.88"	6.12"	.38"	8	M-6.62"	2.75"
1610	5.31"	1.88"	6.88"	6.12"	.38"	8	M-6.62"	2.75"
1610	5.31"	1.88"	6.88"	6.12"	.38"	8	M-6.62"	1.88"
1710	6.09"	1.94"	8.00"	7.25"	.38"	8	M-7.75"	3.00"
1710	6.09"	1.94"	8.00"	7.25"	.38"	8	M-8.00"	3.00"
1710	6.09"	1.94"	8.00"	7.25"	.38"	8	M-7.75"	2.00"
1710	6.09"	1.94"	8.00"	7.25"	.38"	8	M-6.44"	3.00"
1760	7.00"	1.94"	8.00"	7.25"	.44"	12	M-7.75"	3.38"
1810	7.55"	1.94"	8.00"	7.25"	.44"	12	M-7.75"	3.38"
1810	7.55"	1.94"	8.00"	7.25"	.44"	12	M-6.44"	3.31"
1810	7.55"	1.94"	8.00"	7.25"	.44"	12	M-7.75"	2.59"
1880	8.09"	2.18"	9.75"	8.25"	.62"	8	M-7.00"	3.50"
1880	8.09"	2.18"	9.75"	8.25"	.62"	8	M-7.00"	2.50"
1910	-	2.560"	10.875"	9.75"	.629"	8	M-8.75"	4.25"
1910	-	2.560"	8.858"	7.720"	.640"	8	F-5.512"	4.252"
1910	-	2.560"	9.50"	8.250"	.629"	8	M-7.00"	4.25"
1950	-	3.062"	11.188"	9.815"	.754"	12	M-8.250"	8.625"

Flange Yokes

Part number	Series, size	Description	Part number	Series, size	Description
2-2-329	1280/1310	Flange Yokes	6-2-769	1710	Flange Yokes
3-2-119	1350	Flange Yokes	6-2-789 (3)	1710	Flange Yokes
3-2-159	1410	Flange Yokes	6.3-2-19	1760	Flange Yokes
3-2-429	1410	Flange Yokes	6.5-2-329	1810	Flange Yokes
3-2-479	1480	Flange Yokes	6.5-2-349	1810	Flange Yokes
3-2-489	1480	Flange Yokes	6.5-2-359	1810	Flange Yokes
4-2-669	1550	Flange Yokes	8-2-109	1880	Flange Yokes
4-2-679	1550	Flange Yokes	8-2-119	1880	Flange Yokes
4-2-689	1550	Flange Yokes	9-2-269X	1910	Flange Yokes
4-2-699 (3)	1550	Flange Yokes	9-2-99X	1910	Flange Yokes
5-2-249 (1)	1610	Flange Yokes	9-2-219X	1910	Flange Yokes
5-2-279 (1)	1610	Flange Yokes	9-2-59X	1950	Flange Yokes
5-2-379	1610	Flange Yokes	9-2-109	2050	Flange Yokes
6-2-749	1710	Flange Yokes	9-2-119	2050	Flange Yokes
6-2-759 (4)	1710	Flange Yokes	9-2-129	2150	Flange Yokes

[<Back](#) | [Top](#) | [Home](#)

Slip Yoke Assemblies

Part number	Series, size	Description	Part number	Series, size	Description
2-3-258KX	1280/1310	Slip Yoke Assembly	6-3-1661KX	1710	Slip Yoke Assembly
2-3-5221KX	1280/1310	Slip Yoke Assembly	6-3-2631KX	1710	Slip Yoke Assembly
3-3-388KX	1350	Slip Yoke Assembly	6-3-2651KX	1710	Slip Yoke Assembly
3-3-488KX	1350	Slip Yoke Assembly	6-3-2671KX	1710	Slip Yoke Assembly
3-3-118KX	1410	Slip Yoke Assembly	6-3-2741KX	1710	Slip Yoke Assembly
3-3-468KX	1410	Slip Yoke Assembly	6.3-3-21KX	1760	Slip Yoke Assembly
3-3-508KX	1410	Slip Yoke Assembly	6.3-3-41KX	1760	Slip Yoke Assembly
3-3-1511KX	1410	Slip Yoke Assembly	6.5-3-1351KX	1810	Slip Yoke Assembly
3-3-2381KX	1410	Slip Yoke Assembly	6.5-3-1371KX	1810	Slip Yoke Assembly
3-3-1601KX	1480	Slip Yoke Assembly	6.5-3-1431KX	1810	Slip Yoke Assembly
3-3-1621KX	1480	Slip Yoke Assembly	6.5-3-1451KX	1810	Slip Yoke Assembly
3-3-1641KX	1480	Slip Yoke Assembly	8-3-391KX	1880	Slip Yoke Assembly
4-3-1241KX	1550	Slip Yoke Assembly	8-3-411KX	1880	Slip Yoke Assembly
4-3-1261KX	1550	Slip Yoke Assembly	8-3-431KX	1880	Slip Yoke Assembly
4-3-1431KX	1550	Slip Yoke Assembly	9-3-481KX	1910	Slip Yoke Assembly
4-3-1751KX	1550	Slip Yoke Assembly	9-3-481-1KX	1910	Slip Yoke Assembly
5-3-108KX	1610	Slip Yoke Assembly	9-3-221KX	1950	Slip Yoke Assembly
5-3-168KX	1610	Slip Yoke Assembly	9-3-241KX	1950	Slip Yoke Assembly
5-3-188KX	1610	Slip Yoke Assembly	9-3-261KX	1950	Slip Yoke Assembly
5-3-198KX	1610	Slip Yoke Assembly	9-3-331-1KX	2050	Slip Yoke Assembly
5-3-288KX	1610	Slip Yoke Assembly	9-3-331-2KX	2050	Slip Yoke Assembly
5-3-2141KX	1610	Slip Yoke Assembly	9-3-331-4KX	2050	Slip Yoke Assembly
5-3-2261KX	1610	Slip Yoke Assembly	9-3-351-1KX	2150	Slip Yoke Assembly
6-3-1481KX	1710	Slip Yoke Assembly			

[<Back](#) | [Top](#) | [Home](#)

Tubing and Tube Yokes

Part number	Series, size	Description	Part number	Series, size	Description
2-28-367	1280/1310	Tubing/Tube Yoke	6-28-347	1710	Tubing/Tube Yoke
3-28-570	1350	Tubing/Tube Yoke	6-28-347	1710	Tubing/Tube Yoke
3-28-970	1410	Tubing/Tube Yoke	6-28-407	1710	Tubing/Tube Yoke
3-28-557	1410	Tubing/Tube Yoke	6.3-28-17	1760	Tubing/Tube Yoke
3-28-537	1480	Tubing/Tube Yoke	6.5-28-117	1810	Tubing/Tube Yoke
3-28-547	1480	Tubing/Tube Yoke	6.5-28-127	1810	Tubing/Tube Yoke
3-28-507	1480	Tubing/Tube Yoke	8-28-147	1880	Tubing/Tube Yoke
4-28-307	1550	Tubing/Tube Yoke	9-28-37X	1910	Tubing/Tube Yoke
4-28-417	1550	Tubing/Tube Yoke	9-26-38X	1950	Tubing/Tube Yoke
5-28-327	1610	Tubing/Tube Yoke	9-26-18X	1950	Tubing/Tube Yoke
5-28-627	1610	Tubing/Tube Yoke	9-26-197	2050	Tubing/Tube Yoke
5-28-667	1610	Tubing/Tube Yoke	9-26-227	2150	Tubing/Tube Yoke

[<Back](#) | [Top](#) | [Home](#)

Tube Shafts

Part number	Series, size	Description	Part number	Series, size	Description
-------------	--------------	-------------	-------------	--------------	-------------

# Series 1350

	Minimum Lz	Minimum Lc	Lu	Ls	M	C	S	K	B	W
Style	Face to Face	Center to Center	Useable Length	Slip Length	End to Center	Pilot Diameter	Tube Diameter	Swing Diameter	Angle	Spline
<b>Tube Type</b>	14.96"	11.84"	2.50"	3.62"	1.56"	Male 2.75"	3.0"x.083"W	4.62"	20	1.50"-16
<b>Short Couple</b>	9.50"	6.38"	2.00"	.75"	1.56"	Male 2.75"	-	4.62"	8	1.50"-16



# Series 1350

## Tube Type Assembly

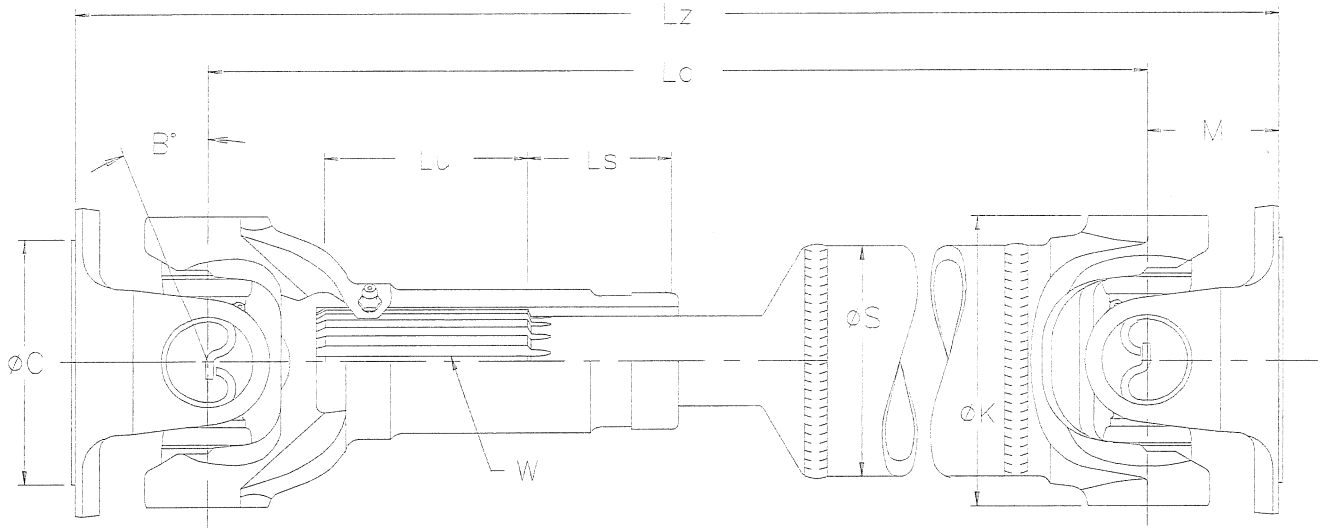

## Short Couple Assembly

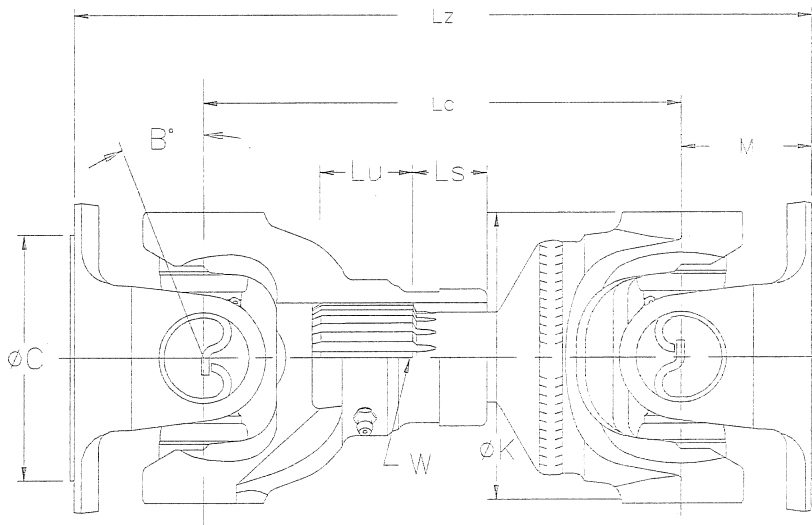

[<Back](#) | [Top](#) | [Home](#)

**Drive Shaft Assemblies**

Part Number	Series	Description
9235-SF	1310	Drive Shaft
9012-SF	1350	Drive Shaft
8134-SF	1410	Drive Shaft
202990-1	1480	Drive Shaft
204249-6	1550	Drive Shaft
906224-1	1610	Drive Shaft
904657-1	1710	Drive Shaft
906052-1	1810	Drive Shaft
906550-1	1880	Drive Shaft
917783	1310	Drive Shaft
917784	1350	Drive Shaft
917785	1410	Drive Shaft
917786	1480	Drive Shaft
917787	1550	Drive Shaft
917788	1610	Drive Shaft
917790	1810	Drive Shaft
917791	1880	Drive Shaft

[<Back](#) | [Top](#) | [Home](#)

**Part/Subpart Universal Joint**

Part number	Subpart number	Part number	Subpart number
G5-3000X	CP3000	G5-6000X	CP62N-DWT
G5-3009X	CP3147X	G5-6101X	CP62N-HB
G5-3105X	CP3147X	G5-6102X	CP62N-HB
G5-4002X	CP4002	G5-6106X	CP62N-HWD
G5-4014X	CP4102	G5-6108X	CP62N50
G5-4015X	CP4015	G5-7000X	CP72N-DWT
G5-4143X	CP4143X	G5-7105X	CP72N-HWD
G5-5000X	CP5000	G5-7202X	CP62N56
G5-5008X	CP5008	G5-8105X	CP82N-HWD
G5-5015X	CP5015	G5-8200X	CP82N-DWT
G5-5121X	CP5101	G5-8201X	CP82N-HB
G5-5177X	CP5177	G5-8202X	CP82N-HB
G5-5800X	CP58WB-HWD	G5-9000X	CP92N-DWT

[<Back](#) | [Top](#) | [Home](#)

©2008 Machine Service, Inc. - All Rights Reserved [Site Map](#)  
 1000 Ashwaubenon Street | Green Bay, WI 54304 | Toll Free 800-677-8711 | 920-339-3000 | Fax 920-339-3001 | [Email](#)



## F E A T U R E S

The 6100 control system is the industry-leading integrated CAN Bus joystick and spreader controller. Embedded within the 10" color LCD, this controller comes fully equipped with camera integration and PreCise MRM cellular and GPS technologies greatly reducing the footprint of components within the cab.

- **High Resolution 10" Color LCD**
  - Displays information-rich graphical spreader data along with up to three camera feeds eliminating the need for multiple displays within the cab.
- **CAN Bus Central Processing**
  - Provides high-level diagnostics and eliminates bulky harnessing.
- **Connectivity**
  - Plug-and-play with a single connector to a trailer system, spreader body or other slide in attachments.
- **AVL/GPS Integration Onboard**
  - Fully integrated with PreCise® MRM hardware and antennas for accurate reporting on route, location, material application, accessory details and more.
  - Convenient over-the-air updates, configuration and troubleshooting.
- **Wireless Technology**
  - Integrated support for PreCise MRM ARC Wireless Air & Road Conditions System
- **Joystick Options**
  - Available as a standalone spreader controller or integrated within our Patrol Commander Ultra or CommandAll Single joystick consoles.



**Product Specifications**

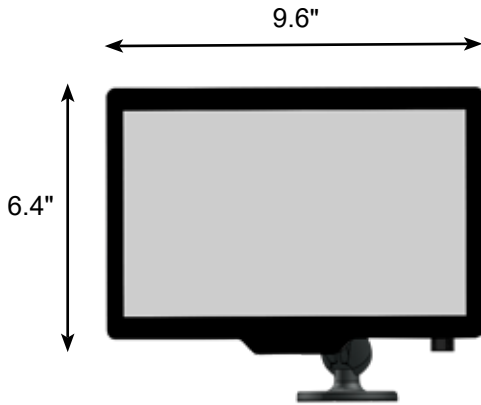

Bright, bold 10" color LCD screen featuring thin borders, capacitance touch for ease of calibration, and a fully-adjustable mounting option for quick installation.



**Cellular Technology**

Convenient over-the-air updates, configuration and troubleshooting.



**Two USB Ports**

Import and export settings without the need of a computer.



**AVL/GPS Integration with Antenna**

Integrated PreCise MRM hardware & antennas for accurate mapping, reporting and real-time information.



**Multiple Camera Feeds**

Supports three camera feeds, eliminating the need for multiple displays within the cab.

**Technical Specifications**

Size .....	6.4" H x 9.6" W x 2.6" D
Case Material .....	ABS plastic
Screen Size .....	10.1"
Screen Resolution .....	1024 x 600 px
Touch Panel .....	Capacitive
Backlighting .....	LED
Operating Voltage .....	9-16 VDC
Operating Current .....	2A
Max System Current .....	40A
Discrete Digital Inputs .....	3
Current Loop (4-20mA) Input...	1
Dashkey Input .....	1
Speedometer .....	Dual Adjustable Trip Point, with pull up enable
USB 2.0 Type A .....	2
Composite Video Inputs	3

Outputs .....	8
• Relay Outputs 1-5 .....	Shared 15A
• Solid State Outputs 6-8 .....	0.25A Each
5V Reference .....	0.1A Limited
12V Reference .....	0.1A Limited
Connectivity: .....	4G Cellular/GPS/2.4 Ghz 802.15.4
Electrical Protection Type .....	Over-current, reverse polarity, load dump, ESD
Electrical Testing .....	J1113/4: Bulk Current Injection 1-400MHz
.....	J1113/21: Immunity to Electromagnetic Fields 20-1000MHz
.....	CISPR 25: RF Radiated Emissions
.....	J1113/13: ESD 4 & 8kV Direct, 4/8/15kV Air
Mechanical Testing .....	SAE1455 Shock
.....	SAE1455 Swept Sine Vibration
.....	SAE1455 Random Vibration

**1-888-99-FORCE**

501 East Cliff Road Burnsville, Minnesota 55337 [www.forceamerica.com](http://www.forceamerica.com)

**Sales and Service Centers**

Bismarck, ND	800-624-7568	Denver, CO	888-833-7711	Minneapolis, MN	800-328-2732
Charlotte, NC	800-788-8598	Fort Dodge, IA	800-362-2994	Philadelphia, PA	800-492-6621
Chicago, IL	800-433-5765	Kansas City, MO	800-383-4724	Salt Lake City, UT	877-230-0505
Columbus, OH	888-449-0356	Memphis, TN	888-845-5876		
Dallas, TX	800-893-7225	Milwaukee, WI	800-722-5844		

F E A T U R E S

The Patrol Commander™ Ultra Series Controller for medium and heavy duty plow trucks is a fully proportional control with integrated spreader control. Ergonomic design allows one-handed, finger-tip control of all spreader functions and up to nine hydraulic functions. Rigid construction ensures product quality for the life of the vehicle.

- **Fully proportional controls**
  - Infinite speed control of up to nine operations simultaneously
- **Swing-up arm**
- **Available in one, two and three joystick configurations**
  - Flexibility to meet specific system needs
- **Multiple joystick types available**
- **Backlit nomenclature**
- **Four programmable single-acting or dual-acting floats**
  - Float available on any joystick axis with optional three second delay
- **Integrated dash-key disconnect**
  - Completely disconnect system from battery when key switch is off
- **Joystick power-on detections**
  - Helps prevent unintended system operation
- **On-board visual diagnostics**
  - Intuitive feedback for troubleshooting



## Product Specifications



**Selectable valve drive frequency** – Full pulse width modulation (PWM) control, selectable valve drive frequency for optimal valve performance.

**Mechanical hoist interlock** – Avoid inadvertent hoist operation for operator safety. Meets OSHA hoist control regulations.

**Solid-state protection** - Self-diagnostic valve output drivers protected against over-current and over temperature conditions.

**Input voltage monitoring** – Prevent unsafe operation during low voltage conditions.

**Conveniently located sander standby, sander blast and body vibrator controls** – Integrated push button controls for driver ease of operation.



**Available in 1100-5100 series spreader controls** – Manual, open and closed loop controls available for granular, pre-wet, anti-icing and dust control.

**Integrated spreader control** – Saves cab space and allows single-handed control of spreader.

**Remote spreader display** – Driver safety and convenience.

**Integrated spinner/blast dials** – A FORCE America innovation that provides simultaneous spinner adjustment while blast is activated.

**Selectable valve drive frequency** – Full pulse width modulation (PWM) control with selectable drive frequency for optimum valve performance.

## Electrical Specifications

Operating temperature range	-40° to 185°F
Operating voltage	10.0 – 16.0 VDC
Operating current	800mA max standby
	50A max with all outputs active
Maximum output current	2.0A
Protection	Over-voltage, under-voltage, Over current, reverse polarity
Valve output type	PWM
Valve drive frequency	50 or 125Hz
Proportional valve drive outputs	18
Float outputs	4

Maximum float output	5.0A@ 12.0VDC
Maximum vibrator output	2.0A@ 12.0VDC
Maximum hoist warning output	2.0A@ 12.0VDC
Blast and standby current	20mA max
Blast and standby output type	Open collector
Blast, standby and vibrator inputs	5.0 VDC
Dashkey input	12.0 VDC
Float enable input	12.0 VDC
Hoist enable input	5.0 VDC
Joystick inputs	RS485 standard



501 East Cliff Road  
Burnsville, Minnesota 55337

1-888-99FORCE  
www.forceamerica.com

© 2008 FORCE America, Inc.

Part Number: FA507

## Service Centers and Sales

Bismarck, ND	800-624-7568	Fort Dodge, IA	800-362-2994
Charlotte, NC	800-788-8598	Kansas City, MO	800-383-4724
Chicago, IL	800-433-5765	Milwaukee, WI	800-722-5844
Columbus, OH	888-449-0356	Minneapolis, MN	800-328-2732
Dallas, TX	800-893-7225	Philadelphia, PA	800-492-6621
Denver, CO	888-833-7711	Salt Lake City, UT	877-230-0505

**MONROE**  
TRUCK EQUIPMENT



POWERED  
BY  
**FORCE**  
America



# I-Grip 6100

*The Complete In-Cab Integration System*

*The Monroe I-Grip control powered by the Force SSC6100 CAN Bus Spreader Control System provides the latest in integrated Hydraulic function controls along with Spreader and Liquid Controls.*



# I-Grip Control

## The Complete In-Cab Integration System

The I-Grip™ incorporates today's technology into a proportional single Joystick which provides an industry-leading approach to hydraulic function control.

The one point-of-contact and one point-of-control design provides the highest degree of operator comfort and system flexibility.

- ▶ **Function Controls with LED Backlit Face**
  - 3-Axis Hydraulic Proportional Control Functions
  - Toggle Operating Modes
  - Select Liquid Lanes

- ▶ **Spreader Controls**
  - Spinner Increase/Decrease
  - Blast On/Off

- ▶ **Spreader Controls**
  - Standby
  - Rate Increase/Decrease

- ▶ **Mode Select Zones**
  - Hydraulic Function Activation
  - Electric Interlock



- ▶ Full Proportional Control
- ▶ Contactless Mode Selection
- ▶ Hi-Flex Cabling for Long-Life, Seat-Mounted Operation



POWERED  
BY  
FORCE

# SSC6100

## CAN Bus Spreader Control System

- ▶ Remotely Mounted in Clear View for Operator
- ▶ 7" Diagonal Color TFT Wide-Screen Display
- ▶ Simultaneous Display of Key Activities:
  - Granular Rate Set-Point vs. Actual
  - Pre-Wet Liquid Set-Point vs. Actual
  - Liquid Anti-Icing Set-Point vs. Actual
- ▶ Selectable On-Screen Data Gauges:
  - Road/Air Temperature
  - Current Material Name
  - Vehicle Speed
  - Spread Width
  - Gate Setting



**Superior  
Operator  
Interface!**

### ▶ Spreader Control

- Two Continuous Rotation Encoders for Granular & Spinner
- Two Integrated Push-Buttons for Blast & Standby
- Multifunction Menu Navigation Control
- Adjustable LED Backlighting
- Color-Coded Knobs & Soft Keys Simplify Operation  
Accelerates Training for New Drivers
- Industry-Leading Safety... Pushing ESTOP Button Immediately  
Removes Power from Actuators to Halt Hydraulic Function Movement



**ESTOP  
Safety Button**

### ▶ CAN Bus Central Processing Module

- Connects the Operator Interface, LCD Color Display & Valve Control Module Into One Multi-Tasking, Information & Control System
- On-Board Diagnostics Provide Real-Time Status of Sensors, Outputs and System Communications
- USB Port for High-Speed CAL File Transfer and Firmware Upgrades -- No PC Required



**MONROE**  
TRUCK EQUIPMENT

**POWERED  
BY  
FORCE**

# Valve Control Module

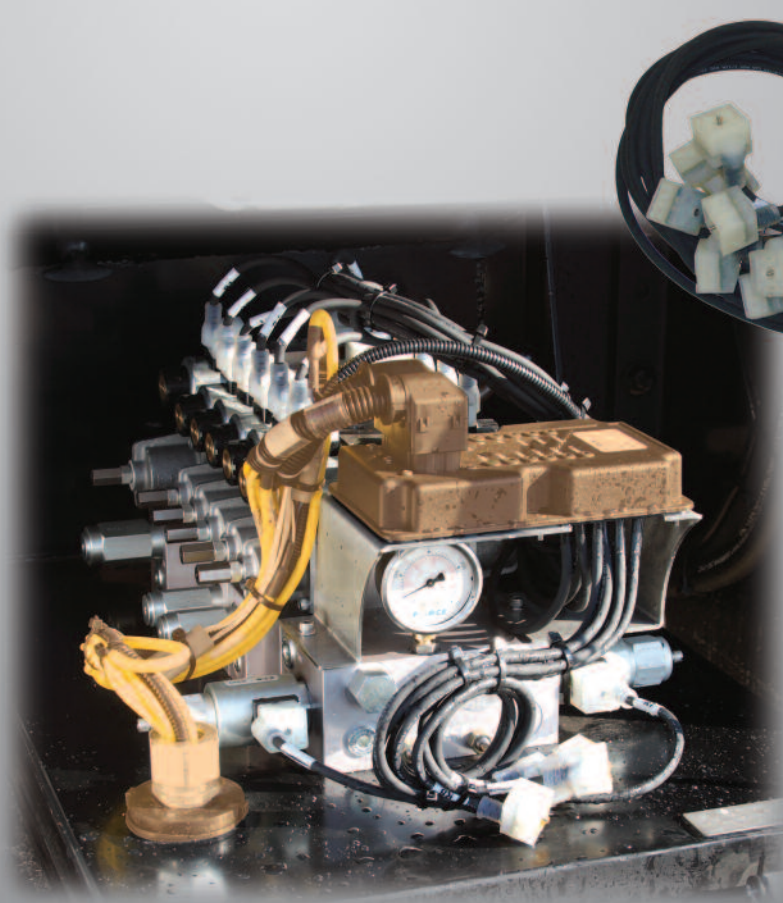

*The Valve Control Module was developed on the robust CAN Bus communication protocol to eliminate bulky wire harnesses.*

*Constructed to meet harsh environmental standards and pre-installed on the valve assembly; making it the perfect companion for the Force America family of valves.*

- ▶ **Potted Module & Connectors Seal Out Water & Protect Against Vibration**
- ▶ **CAN Bus Interface to Controller Reduces Wiring Through Cab Floor**
- ▶ **Feedback Inputs for Sensors**
- ▶ **Warning Sensor Inputs**
- ▶ **Proportional/Non-Proportional Operation**
- ▶ **CAN Bus Output Connector to Additional Modules**
- ▶ **On-Board Diagnostics which Provide Real-Time Status of Sensors, Outputs & System Communications**



POWERED  
BY  
**FORCE**



800.356.8134



[www.monroetruck.com](http://www.monroetruck.com)

Monroe Truck Equipment  
1051 W. 7th Street  
Monroe, WI 53566



1051 W. 7<sup>th</sup> Street  
Monroe, WI 53566  
608-328-8127 • 800-356-8134

## Truck Equipment Installation & Modifications Limited Warranty

### Monroe Truck Equipment Limited Warranty

All components and products manufactured and installed by Monroe Truck Equipment (MTE) are warranted to be free from defects in material and workmanship for either (1) year from the date of purchase or (1) year from the date that the vehicle was put in service by its original operator, or 12,000 miles whichever occurs first.

All MTE workmanship, whether installation of MTE products or purchased components, fabrication, or repair, is covered for the same 12 month/12,000 mile warranty.

This limited warranty is the sole and exclusive remedy for defective product manufactured and/or installed by MTE.

This limited warranty covers only components manufactured by MTE. Except for installation workmanship, this limited warranty does not pertain to components manufactured by non-MTE suppliers and purchased by MTE, regardless of whether these components were selected or recommended by MTE.

### Purchased Materials and Components Warranty

MTE sells and installs many components manufactured by and purchased from other suppliers. These components are covered by the warranty policies of the individual suppliers. MTE will, as a service to the buyer, pass on any warranties received from the manufacturer of these components and will process warranty claims related to supplier products. Unless the end user chooses to work directly with a non-MTE component supplier, MTE shall act as intermediate between the end user and the component supplier.

Non-MTE supplier policies typically differ from the MTE limited warranty. MTE has no control over the warranty policies of other suppliers and shall not deviate from a supplier's warranty without express written permission from that supplier.

Any and all claims concerning non-MTE components must be forwarded to MTE within 10 days of the discovered defect. All documentation of said claims must be accompanied with the identification number of the vehicle and/or a copy of the invoice. MTE has, at their option, a choice of whether to repair or replace the defective part at a MTE repair center or a location approved by MTE unless otherwise specified by the manufacturer.

### Peripheral, Incidental, and Consequential Damages and Claims

The MTE limited warranty does not apply to damage and failure resulting from misuse, abuse, neglect, accident, improper customer/distributor installation, lack of maintenance, or acts of God. Any modifications by the buyer or any third party, without the prior written consent of MTE, may void this warranty. Operating conditions, or applications not made known to or contemplated by MTE at the time of delivery to the buyer may also void this warranty. Damages resulting from any other abnormal operation will not be covered by this warranty.

Normal maintenance, wear, and consumable items such as oils, coolants, fluids, tires, belts, hoses, filters, air cleaners, and light bulbs supplied in connection with goods or services provided by MTE are not covered under this warranty.

MTE will not reimburse for lost time, business, or business opportunity, or for any loss of use related to warranty claims. MTE will not provide or pay for the use of a rental vehicle, equipment, or tools while warranty work is performed. MTE will not reimburse for equipment or tools that are damaged, lost, or missing in conjunction with a warranty claim.

### Warranty Repairs Performed by MTE or Authorized Agents

Whenever possible and feasible, warranty repairs shall be performed at an MTE facility or at an authorized distributor or dealer. In some instances, an MTE Field Service representative may repair the vehicle at the owner's selected location.

MTE may, at its discretion, pick up and return the vehicle to the owner's location or may request that the owner deliver the vehicle to the repair site. MTE is not responsible for and will not reimburse for mileage, fuel, and wear incurred in the process of driving the vehicle to a repair site, road testing, or delivery to the end user location, nor for lost time incurred by an owner delivering and picking up a vehicle.

### Warranty Repairs Performed by Non-MTE Entities

In certain circumstances, MTE may authorize the vehicle owner, a dealer, a distributor, or another third party to perform warranty repairs. MTE will then reimburse the entity performing the work for components used and for labor to perform the repairs. Any such decision will be based on type of repair, distance to the nearest approved MTE repair site, and urgency of the repair.

**Except for emergencies, MTE must grant authorization and permission before a non-MTE entity begins repair or replacement of components. Warranty claims for unauthorized and unsubstantiated work may be denied.**

If MTE authorizes the buyer or a third party to repair or replace the defective parts instead of MTE doing such work itself, the buyer shall be invoiced for the replacement parts. Credit will be given pending the return of the defective parts and warranty issued by manufacturer. Authorized warranty work not performed by MTE will be at the rate of **\$43.50/hr**, and invoices for authorized work will be paid net 30. In the event that MTE and the second party cannot come to an agreement, a binding third party arbitrator will be chosen with the mutual consent of both parties.

Electrical and hydraulic components are not to be disassembled without the express written consent of MTE. All defective parts returned must be accompanied by the manufacturers' model, serial number, and date of installation. Any parts returned for warranty must be returned with freight prepaid.



1051 W. 7<sup>th</sup> Street  
Monroe, WI 53566  
608-328-8127 • 800-356-8134

## How to Obtain Warranty Service from Monroe Truck Equipment

### Making an Appointment for Warranty Service at an MTE Facility or Authorized Repair Site

1. Obtain the following information:
  - Vehicle Identification Number (VIN)
  - Type, model, and serial number of component or product requiring service
  - Number of original MTE Sales Order if available
  - Name of dealer that vehicle was purchased from if known
  - Date of purchase/in-service date if known
  - Detailed description of the problem
2. Call the MTE location where your truck was built. The build location will be marked on the yellow certification label in or near the driver's door jamb.
  - Monroe, Wisconsin: 1-608-329-8437 (Warranty Dept.) or 1-800-356-8134 (ask for Warranty Dept.)
  - Flint, Michigan: 1-877-233-2030 (ask for Warranty Dept.)
  - De Pere, Wisconsin: 1-800-848-5400 (ask for Service Dept.)
  - Marshfield, Wisconsin: 1-800-882-1900 (ask for Service Dept.)
  - Joliet, Illinois: 1-800-892-7052 (ask for Service Dept.)
  - Galion, Ohio: 1-419-777-7120 (ask for Service Dept.)
  - Louisville, Kentucky: 1-502-426-0990 (ask for Service Dept.)
3. Discuss the problem with the Warranty representative to determine resolution and repair schedule.

***Please let the Warranty representative know if your vehicle was sold with an extended or other non-standard warranty policy!***

### Requesting Authorization to Perform Warranty Work or Payment for Work Performed

1. Obtain the following information:
  - All of the information requested in item #1 above, plus:
  - Documented photographs for any physical damage. (paint, dents, etc.)
  - Inspection notes by MTE personnel or a third party representing MTE if necessary.
2. Call the MTE location where your truck was built. The build location will be marked on the yellow certification label in or near the driver's door jamb. See the location list in item #2 above.
3. Discuss the problem with the Warranty representative to determine coverage and repair method.
4. The representative will grant permission to perform repairs if approved.
5. The representative will issue a Returned Goods Authorization (RGA) number.
6. Defective parts must be returned freight prepaid to MTE within ten days.
7. If the affected component was purchased from a non-MTE supplier, please allow extra time for MTE to contact and work with the supplier.

***Monroe Truck Equipment reserves the right to deny any warranty if the procedures detailed above are not followed. Proper documentation, including photos, must be provided in order for MTE to validate and approve any claim submitted after repairs are done.***

# PLOWHITCHES

Designed to withstand the harshest winter conditions



HITCH | PIN

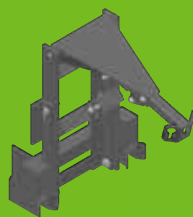

HITCH | QUICK



HITCH | LOOP STYLE



HITCH | HUSTING



HITCH | QUICK LINK

# Hitch | Pin Type

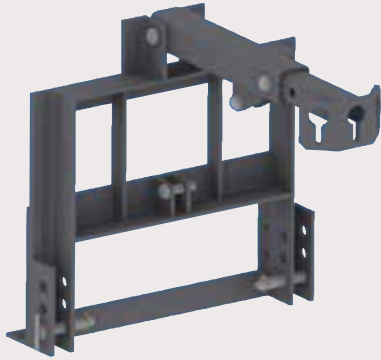

**MC5000**

- Low Profile Design
- Available in 21", 30.5", & 33.5" Centers
- Non Tilt
- Telescopic Lift Arm

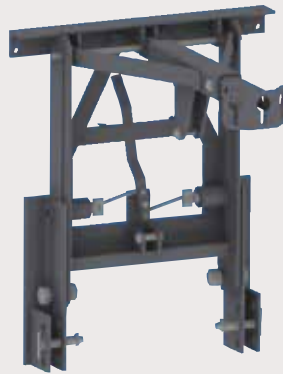

**MC201**

- High Profile Design
- Available in 30.5" & 33.5" Centers
- Tilting with Lever Release for Locking
- Telescopic Lift Arm



**MC8002**

- High Profile Design
- Available in 21", 30.5", & 33.5" Centers
- Tilting
- Telescopic Lift Arm

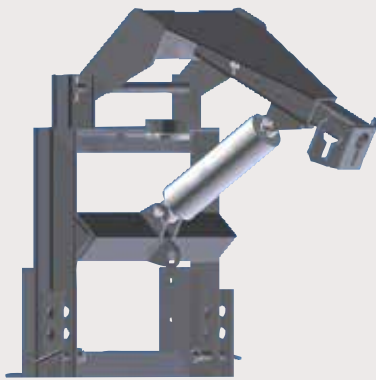

**00011210 MC5000-FFLA**

- Low Profile Design
- Available in 30.5" Centers
- Non-Tilt
- Telescopic w/Fold Flat Lift Arm

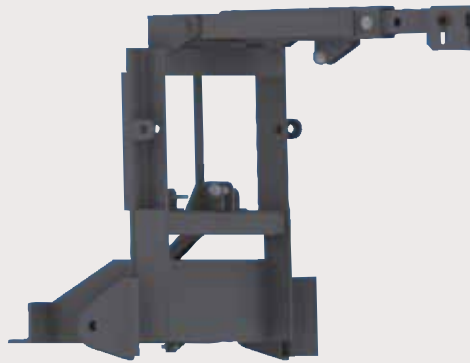

**00031835 26B**

## Plow Portion



**Pin Style Swivel Hitch Also Available in 21", 30.5", & 33.5" Center**

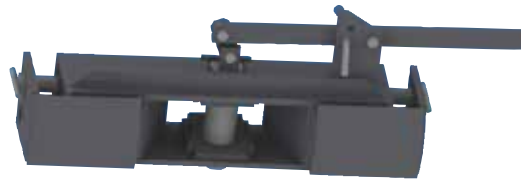

**MC801 Field Conversion Kit to Convert Pin Style to Loop Style Hitch**



**Pin Hitch for 26B Style Hitch**

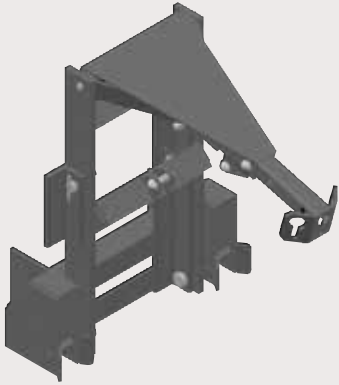

- MC7082**
- High Profile
  - Positive 2 Point Latch System
  - 30.5" Centers
  - Manual Tilt
  - Telescopic Lift Arm

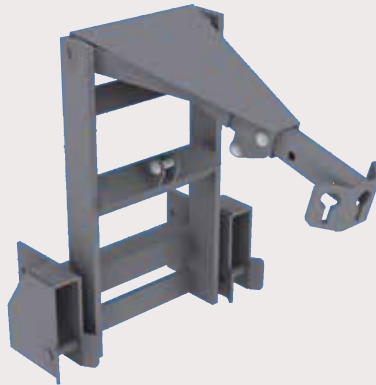

- MC7083**
- High Profile
  - Positive 2 Point Latch System
  - 30.5" Centers
  - Non Tilt
  - Telescopic Lift Arm

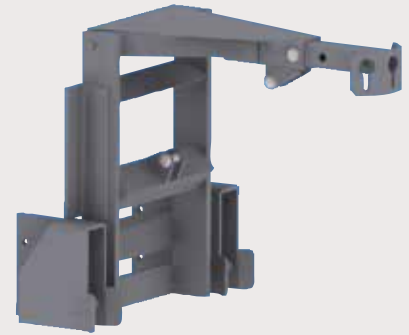

- 00015137 MC7000**
- Low Profile
  - Positive 2 Point Latch System
  - 30.5" Centers
  - Non Tilt
  - Telescopic Lift Arm

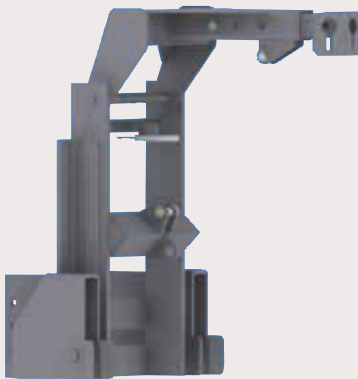

- 00054392 MC7090**
- Low Profile
  - Positive 2 Point Latch System
  - 30.5" Centers
  - Non Tilt
  - Telescopic w/Fold Flat Lift Arm

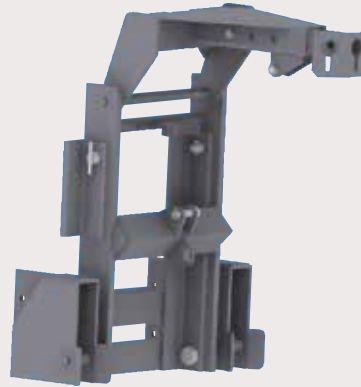

- 00102712 MC7092**
- Low Profile
  - Positive 2 Point Latch System
  - 30.5" Centers
  - Manual Tilt
  - Telescopic Lift Arm



## Plow Portion

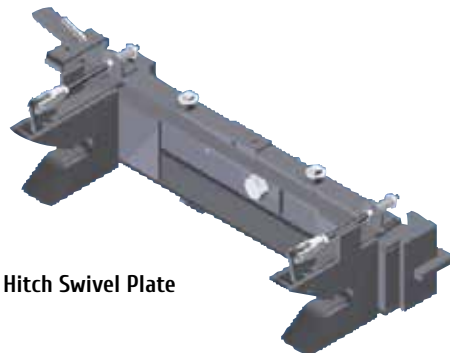

**MC6000 Quick Hitch Swivel Plate**



# Hitch | Loop Style



**MC2080 Pin Loop**  
- Low Profile  
- Non Tilt  
- Telescopic w/Fold Flat Lift Arm



**QCP/FFLA**  
- Low Profile  
- Non Tilt  
- Telescopic w/Fold Flat Lift Arm

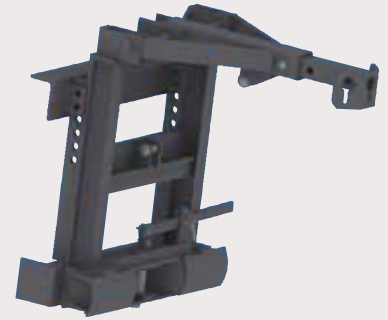

**MC2075**  
- Low Profile  
- Non Tilt  
- Telescopic Lift Arm

# Plow Portion

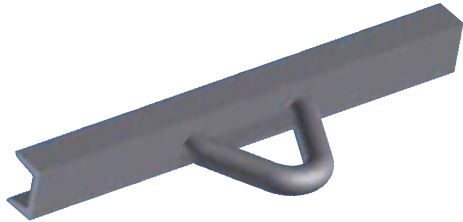

**QCP Loop Weld On Style**

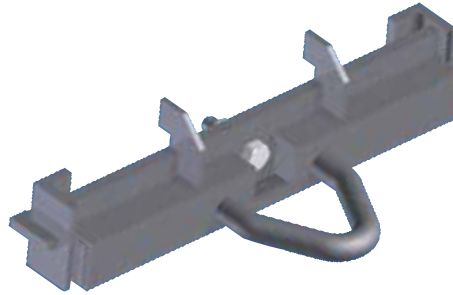

**QCP Loop Bolt On Style Swivel Plate**

# Hitch | Husting

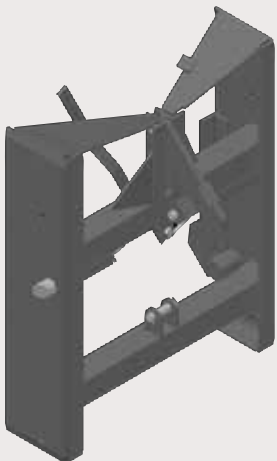

**Husting Hitch**  
- Available in 29" & 34" Wide

# Plow Portion



**Husting Hitch Plow Portion**



**00043300 Roller Kit**

# Hitch | Quick Link

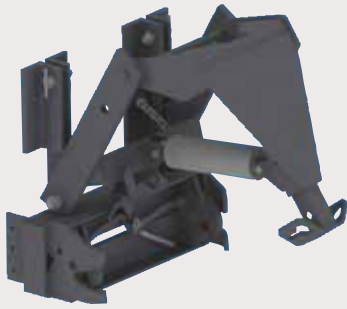

- PF91-QL1/FFLA/Tilt
- Low Profile
  - Tilt
  - Telescopic w/Fold Flat Lift Arm



## Plow Portion

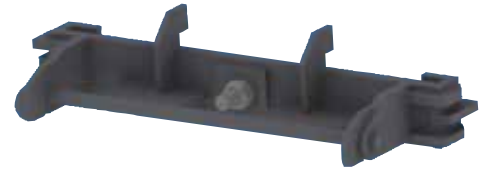

Quick Link Swivel Plate Hitch

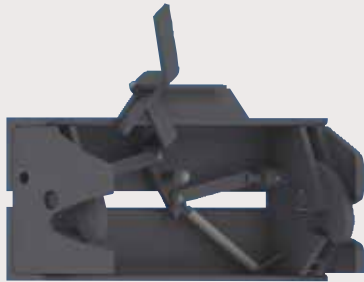

- PF91-QL1/FFLA 00052633
- Low Profile
  - Non Tilt
  - Telescopic w/Fold Flat Lift Arm

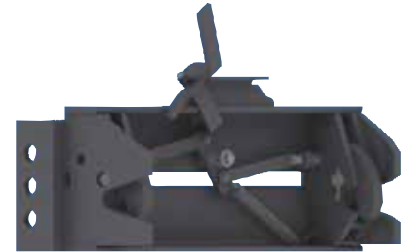

00059247 Field Conversion Kit

# Hitch | Tor-Lock/Arrowhead

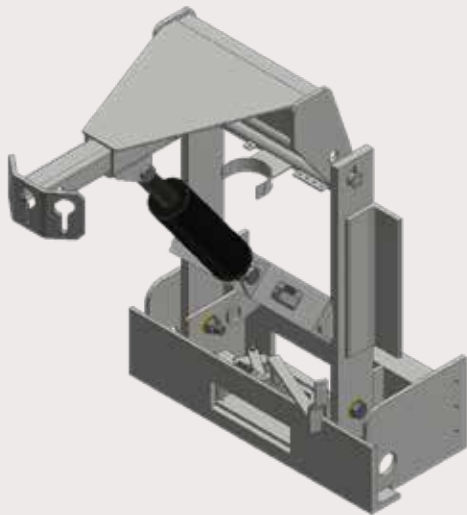

- Tor-Lock or Arrowhead
- Low Profile
  - Non Tilt
  - Telescopic w/Fold Flat Lift Arm
  - Integral Arrowhead Receiver

## Plow Portion

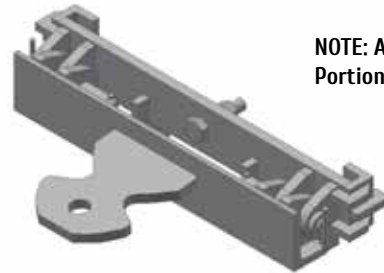

NOTE: Available in Weld On Plow Portion without Swivel Plate

Oscillating Plow Portion Tor-Lock/Arrowhead Hitch



MC9001 Field Conversion Kit

# Hitch | Custom



00016541 Power Tilt



00029185 Power Tilt Quick Hitch with Wing Cross Tubes

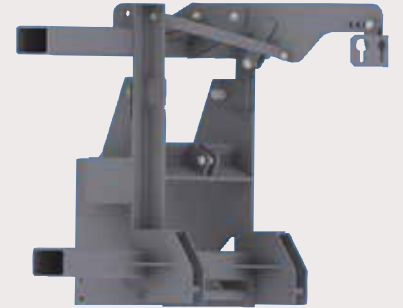

Flat Plate Hitch

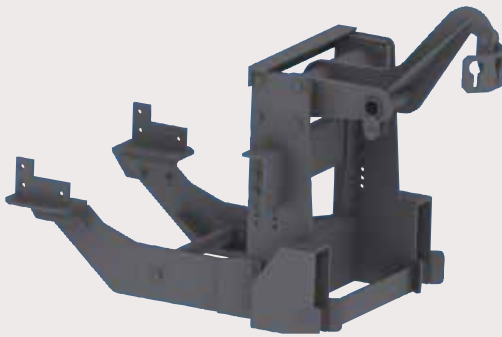

00039044 MTA8000-Q

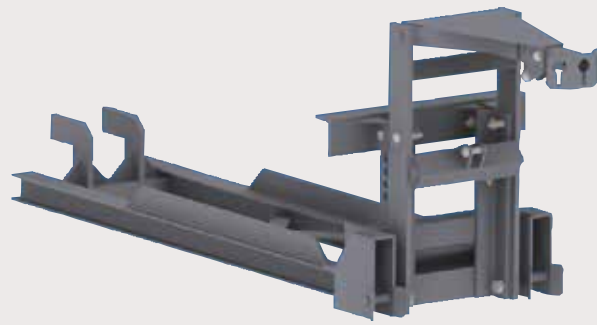

00091753 UBA Quick Hitch



## Side Plates

SPU  
½" Universal  
Side Plates

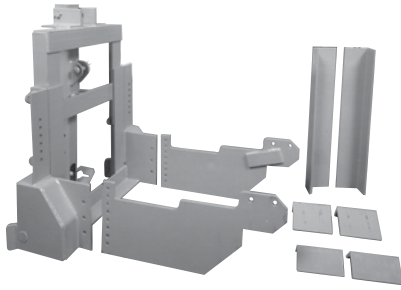

*Hitch is not included  
with the side plates.*

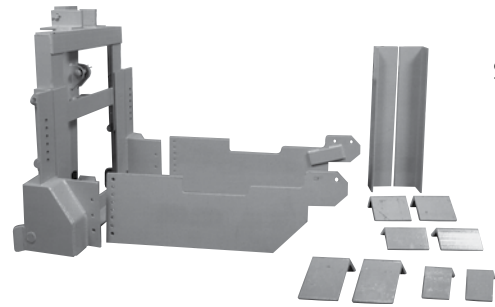

SPU  
½" Universal  
Side Plates for  
Chassis with  
Frame  
Extensions

*NOTE: Some modifications may be required for hitch installation.  
Product updates and specifications are subject to change without notice.*

## Thrust Arm Kits



MC50  
Thrust Arm  
Mounting Kit

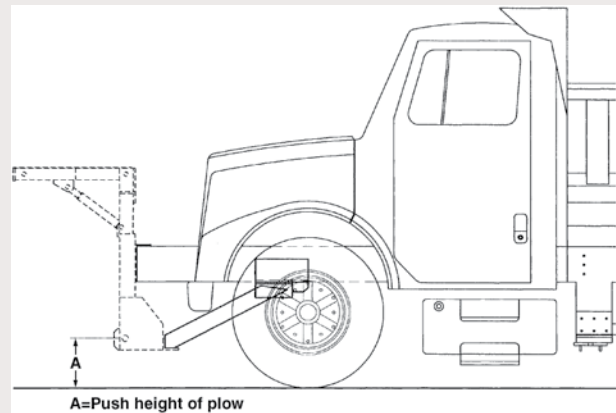

## Hitch | Replacement HH Roller Pin

PN: 05022221  
Pin Assembly with Roller, Grease Fitting, & Machine Nut

**NOTE:**  
MTE roller pins for Husting-style hitches will not latch properly with angled hitch reinforcements. Plow-portion hitches must have a C-channel style reinforcement to prevent interference with the roller pins.

Older plow hitches must be updated with C-channel (Part #00137630) when used with MTE roller pins.

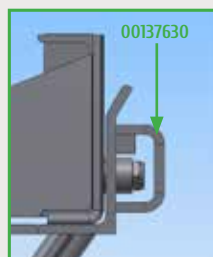
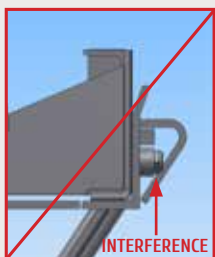

- Reduces Hitch/Plow Hang Up
- Replaces Standard Pins
- Hardened Pin (RC30)
- Hardened Roller (RC60)
- Greaseable Roller

1.875" Dia. Stress-Proof Pin RC30

Hardened Roller RC60

**4 LOCATIONS  
TO SERVE YOU**

**MONROE, WI  
MARSHFIELD, WI  
DE PERE, WI  
JOLIET, IL**



**[municipal.monroetruck.com](http://municipal.monroetruck.com)  
800-880-0109**



# LIQUID SYSTEMS

Designed to withstand the harshest winter conditions



LIQUID | PRE-WET



LIQUID | ANTI-ICE



LIQUID | DUST CONTROL

# Liquid | Pre-wet Systems

Pre-wet - Application of a liquid chemical ie. Salt brine, calcium chloride, magnesium chloride, etc. to a granular material.

## Why Pre-wet?

1. Faster reaction time to start the brine process.
  - In order for the rock salt to break down, it must have moisture.
2. More material stays on road surface where spread.
  - Test results from many states show that on average, 30% of dry salt is lost off the road surface upon application.
3. Allows you to use less product.
  - Salt that has been pre-wetted has a loss rate of 4% on average.



## Components of a Pre-wet System



**Tanks** - Available in many different volumes and shapes. Poly tanks have integrally molded threads, baffles and sash guards for the lid



**Pump** - Hydraulic or Electric Displacement is typically from 3-10 gallons per minute.



**Nozzles**



**Plumbing Fittings**



## Open Loop vs. Closed Loop

Closed Loop has a flow meter installed in the plumbing to measure flow. The flow meter emits electrical pulses that are received by a ground speed controller. The control monitors the amount of pulses relative to granular product dispensed.

Open Loop does not contain a flow meter. It may be driven off of the exhaust oil of the conveyor so that as the conveyor speeds up the pre-wet pump also increases. This keeps your ratio of granular to liquid equal.

\*Photo shows tank configuration of 940 total gallons (540 on body and 400 behind cab)



**Tailgate Mounted Pre-wet System**

75-180 gallons  
100 gallons shown in photo



**Behind the Cab Pre-wet System**

120-400 gallons  
240 gallons shown in photo



**1500 Gallon Insert Tanks**



**V-Box with Pre-wet System**



**In-Bed Tank Pre-Wet System**

526 or 960 gallons



**Fender Mounted Pre-wet System**

75-270 gallons per side  
150 gallons per side shown in photo  
Tanks are custom sized to fit body



# Liquid | Anti-Icing

- 200-5000 Gallon Baffled Tanks
- 20-60 Gallon per Lane Mile; 1-3 Lanes
- USA Made Glass Filled Poly Fittings with Manifold Style Connections
- Right Hand, Left Hand and/or Center Lane Applicators
- Stainless Steel Spray Bars
- Stainless Steel Filter Screen
- Directable Side Nozzles
- Quick Attach Nozzles
- Application Rates up to 55 MPH
- Dump Body Slip-In, Chassis Mounted, Trailer Mounted, or Hook Loader Units Offered
- Hook Loader Mounted Units Offered
- Self-Storing/Unloading Skid System (Optional)
- Reduce Overall Winter Operation Costs
- Use Less Rock Salt
- Get the Pre-Treating Advantage on Fighting a Storm
- Environmentally Friendly
- SHRP (Strategic Highway Research Program) Tested Technology





Flush & Dust Capable



Semi Trailer Anti-Ice

# Liquid | Roadside Vegetation



2700 Gallon Flusher System w/ Removable Rear Skid

Equipped with 1 to 4  
Chemical Injection System

## Features:

- Tanks:
- Carrier Tanks 500-3000 Gallon
- Chemical Tanks 30-85 Gallon
- Color Coded Chemical Lines
- Stainless or Cast 190GPM Chemical Pump
- 500-700GPM Flusher Pump
- Load Sensing Hydraulic System
- Raven 4600/4400 Control Console
- Closed Loop Flow Meters
- GPS/Radar Ground Speed
- Data Collection with Mapping Capabilities



1300 Gallon, 4 Product Injection System with Sign Board Option



1000 Gallon System w/ Removable Skid



2700 Gallon Unit



Pressure Regulator For Spray Head



Guard Rail Underbody Spray Booms  
Manual or Power Height Adjustable  
Optional Spot Light Shown



Spray Head: Front, Mid or Rear Mounted.  
Multi-Zone Spray Load with 30° Linear  
Actuation Tilt to Follow Ground Contour.

## Street Flusher System



**4 LOCATIONS  
TO SERVE YOU**

**MONROE, WI  
MARSHFIELD, WI  
DE PERE, WI  
JOLIET, IL**



**[municipal.monroetruck.com](http://municipal.monroetruck.com)  
800-880-0109**



# PLOWWINGS

Designed to withstand the harshest winter conditions



WING | JUNIOR



WING | PATROL



WING | BENCHING



[municipal.monroetruck.com](http://municipal.monroetruck.com)



**MONROE**  
MUNICIPAL TRUCK EQUIPMENT

# Wing | Junior



Model #	Weight	Moldboard Length
MJW-6	960 lbs.	6'
MJW-7	995 lbs.	7'
MJW-8	1,030 lbs.	8'
MJW-9	1,065 lbs.	9'

## Standard Features:

- 27" Intake Height and 28" Discharge Height on Moldboard
- Two Double-Acting Cylinders for Direct Lift of Toe and Heel
- Direct-Lift Front Wing Slider Post, Options available for Mid-Mount Paraglide
- Wing Requires Two 4-Way Valves with 2100 PSI Relief for Heel Raise to Operate (Not included)
- Wing Provided with Under Frame Cross Tube Mounting and Hardware
- Moldboard is Shot Blasted and Powder Coat Painted Orange
- Mounting Hardware is Powder Coat Painted Black
- 10 Gauge Moldboard
- 3/8" One Piece, Tapered, Flame Cut Ribs

## Options:

- Available with Monroe Para-Glide® Wing Post
- Right, Left or Dual Mount
- Mid or Rear Mount
- Cast Iron Moldboard Shoe to Extend Cutting Edge Wear
- Wrap Around Curb Guard to Prevent Moldboard Heel End Damage
- Carbide Cutting Edge for Longer Cutting Edge Life
- Two-Piece Torsion Spring Trip Cutting Edge
- Full Moldboard Trip
- Decell Heel Cylinder to Slow the Heel Lift Cylinder Function When Activating it to Stow the Wing, Thus Helping to Prevent Damage to the Chassis or Body



Shown with Full Trip Option



Shown with Trip Edge Option

## Reasons for Use:

- Takes up less room on truck frame, can be mounted behind the cab or to the rear of the chassis
- Folds tightly to truck for use in tight areas
- Dump box can be raised with moldboard in stow position (in most cases)
- Paraglide mid-mount post can be used in place of slider post to prevent hang-ups and moldboard toe from "digging in"
- Slider post offers 12" of lift
- Paraglide post offers 5" of lift
- Good visibility to operator from passenger side mirror

# Wing | Mid-Mount Extendable

Model #	Weight	Moldboard Length
8-MEW	1,275 lbs.	8'



Mid-Mount Extendable Wing

## Standard Features:

- 24" Height x 8' Length Moldboard
- 1/2", Tapered, One-Piece, Flamecut Ribs
- 5/8" x 8" AASHO Top Punched Cutting Edge
- Wing Provided with Under Frame Cross Tube Mounting and Hardware
- Wing Requires Two 4-Way Valves & One 3-Way Valve to Operate (Not included)
- Two Double-Acting Cylinders; One Extension Cylinder and One Heel Cylinder
- One Single Acting Cylinder for Toe
- Moldboard is Shot Blasted and Powder Coat Painted Orange
- Mounting Hardware is Powder Coat Painted Black
- Non-Trip Moldboard
- 10 Gauge Continuously Welded Moldboard

## Options:

- Cast Iron Moldboard Shoe
- Wrap Around Curb Guard
- Tapered Moldboard for Additional Snow Load Capacity
- Carbide Cutting Edge
- Special Paint/Colors



## Reasons for Use:

- Simple light duty design for widening the plowing swath
- Offers very light duty benching capabilities
- Small footprint on truck frame allows installation in areas other wings won't fit
- Extended hydraulically perpendicular to the truck frame with additional cylinders to operate the toe and heel
- Easily visible to the operator from the passenger side mirror
- Wing tucks up tightly to the dump body for easy maneuverability and storage



# Wing | Patrol



The perfect complement to your front plow or mid-mount underbody scraper, Monroe's Patrol Wing with advanced technology Paraglide trailing link post will increase your productivity by combining two plowing operations (front and widening) into a one-pass, one-operator trouble-free task. In addition, the Paraglide post reduces the risk of the moldboard toe digging into the ground to help prevent catastrophic damage when the moldboard slams into the passenger side cab door as can happen with conventional slider posts.

Model #	Weight	Moldboard Length
8SFWMB	1,400 lbs.	8'
8DFWMB	1,425 lbs.	8'
9SFWMB	1,450 lbs.	9'
9DFWMB	1,475 lbs.	9'
10SFWMB	1,500 lbs.	10'
10DFWMB	1,525 lbs.	10'
11SFWMB	1,545 lbs.	11'
11DFWMB	1,675 lbs.	11'
12SFWMB	1,600 lbs.	12'

Model #	Weight	Moldboard Length
8DFWMB	1,425 lbs.	8'
9DFWMB	1,475 lbs.	9'
10DFWMB	1,525 lbs.	10'
11DFWMB	1,675 lbs.	11'

## Standard Features:

- 100% Welded Moldboard
- 1-Piece 1/2" Interlaced Moldboard Reinforcement Ribs
- Free Float to Follow Contour of Road to Shoulder
- Rear Push Mount Installed Above Frame for Increased Ground to Rear Mount Clearance (Other Mounts also available)
- 100% Powder Coat Finish

## Options:

- Two-Piece Torsion Trip Edge
- Left Side or Dual Mount
- Moldboard Wear Shoe to Extend Cutting Edge Wear
- Power and Manual Tilt Front Hitches
- Full Trip Moldboard
- Carbide Cutting Edge for Longer Cutting Edge Life
- Special Paint
- Dual Pusharms
- Power Heel Slide for On-the-Go Swath Widening from the Cab
- Curb Guard to Prevent Moldboard Heel End Damage
- Decell Cylinder to Slow the Heel Lift Cylinder Function when Activating it to Stow the Wing, Thus Helping to Prevent Damage to the Chassis or Body
- Marker Kit



*Unique Interlaced Rib Design*



**NEW!** *Adjustable Float Link Design*

Specifications	DFPW-8	DFPW-9	DFPW-10	DFPW-11	DFPW-12
Overall Moldboard Length	104"	116"	128"	140"	152"
Cutting Edge Length	8'	9'	10'	11'	12'
Height of Moldboard at Nose	29"	29"	29"	29"	29"
Height of Moldboard at Heel	39"	39"	39"	39"	39"
Moldboard Thickness	3/16"	3/16"	3/16"	3/16"	3/16"
Weight of Complete Wing Assembly	1,620 lbs.	1,690 lbs.	1,870 lbs.	1,985 lbs.	2,050 lbs.
Weight of Moldboard	700 lbs.	770 lbs.	840 lbs.	720 lbs.	785 lbs.
Clearing Width with 90° Pusharm Angle	58"	65"	72"	79"	87"

# Para-Glide WING POST

U.S. Patent No. 8,596,376



U.S. Patent No. 8,596,376

## Standard Features:

- Full Floatation Reduces Road Shock and Vibration to the Vehicle
- Longer Service Life and Fewer Repairs with Increased Safety
- Faster Cycle Times
- Trailing Link Design Reduces the Risk of the Moldboard Toe End Digging into the Ground and Kicking Up into the Truck Cab
- 14" Full Float with 18" of Lift
- Front, Mid or Rear Mounts Available
- Primary Pivot Pins are Center Line Drilled from Each End and Have a Cross Hole for Greasing

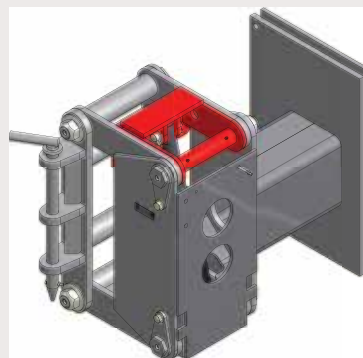

*Para-Glide® Wing Post in Resting Position.*

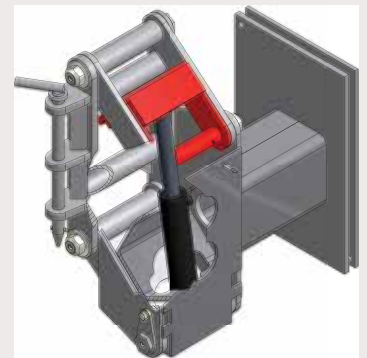

*Para-Glide® Wing Post in Full Float Position.*

# Wing | Heavy Duty Benching



Model #	Weight	Moldboard Length
9HDBW	3,350 lbs.	9'
10HDBW	3,420 lbs.	10'
11HDBW	3,460 lbs.	11'
12HDBW	3,520 lbs.	12'

## Standard Features:

- 3/16" Formed Moldboards
- 4" x 4" x 3/4" Moldboard Bottom Angle
- 1/2" Moldboard Ribs
- Structural I-Beam, Direct-Lift Front Post with 3 1/2" x 62" Lift Cylinder
- Single Telescoping, Three-Position Adjustable, Spring Cushioned Pusharms with Shear Pins
- 100% Powder Coated Orange

## Options:

- Rubber Snow Deflector
- Custom Side Plates
- Cast iron Moldboard Shoe
- Wrap-Around Curb Guard to Prevent Moldboard Heel End Damage
- Cable Lift Front Post
- Carbide Cutting Edge for Longer Cutting Edge Life
- Rear Valve Cabinet & 40 Gallon Reservoir
- Left Side Mount
- Full Trip or Torsion Trip Moldboard
- Straight Moldboard
- Optional Front & Rear Posts
- 40" Benching Height

## Reasons for Use:

- Provides powerful widening and benching capabilities
- High-Lift front post allows operator to push back existing snow windrows into a "bench," getting snow out of the way of the road surface
- The answer for deep piled or drifting snow where brush, trees, ditches, and high banks prevent typical widening operations with a standard patrol wing

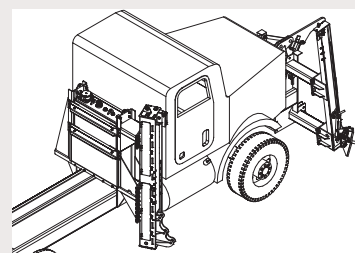

Rear Valve Cabinet & 40 Gallon Reservoir



**LaCrosse**  
**Dual Front Mount Wings**



**South Dakota D.O.T.**  
**Dual Mid-Mount Wings**



**LaCrosse**  
**LH Wing, Front View**



**Town of Dairyland**  
**Piggyback Style Hydraulic Kit**

**Town of East Troy**  
**Heavy Duty Benching Wing**



**Iowa County**  
**Straight Front Mount Paraglide Wing**

**4 LOCATIONS  
TO SERVE YOU**

**MONROE, WI  
MARSHFIELD, WI  
DE PERE, WI  
JOLIET, IL**



**[municipal.monroetruck.com](http://municipal.monroetruck.com)  
800-880-0109**





# Para-Glide WING POST

by Monroe Snow & Ice Control

The Monroe Para-Glide Double Function Patrol Wing is a multi-function wing that is capable of patrolling snow to widen shoulders or perform limited benching. The Para-Glide Double Function Wing is operated by hydraulic cylinders for positive activation of the wing. The operator has the ability to independently control the toe or heel of the wing. Another feature is the built in mechanical float to allow the wing to follow the contour of the plowing surface. The mounting of this wing usually requires no modification to the exhaust system, no additional cab to body spacing, no drivetrain interference and a rear mount that is located above the frame for an unobstructed ground to frame clearance. A Monroe Para-Glide Wing will increase your plow clearing capacity, increase operator efficiency, and reduce equipment road mile usage.

Two 4-way (double acting) valves are required • All moldboards are shotblasted and powder coated Urethane Orange

## Features

- NEW and Improved Free Flotation Reduces Road Shock and Vibration to the Vehicle
- Longer Service Life and Fewer Repairs with Increased Safety.
- Faster Cycle Times
- Trailing Link Design
- 14" Full Float with 18" of Lift
- All Hydraulically Operated- No Cables
- Heavy Duty Construction with High Tensile Steels being Used to Reduce Weight of Assembly and Increase Durability
- 100% Welded Moldboard
- One Piece 1/2" Moldboard Reinforcement Ribs
- Rear Push Frame Mounted Above Frame for Increased Ground to Frame Clearance
- Single Adjustable Spring Cushioned Push Arm with Safety Shear Pin on 8' and 9' Wings. Double Push Arms on 10', 11' and 12' Wings
- No Additional Cab to Body Spacing Required for Rear Push Arm Frame

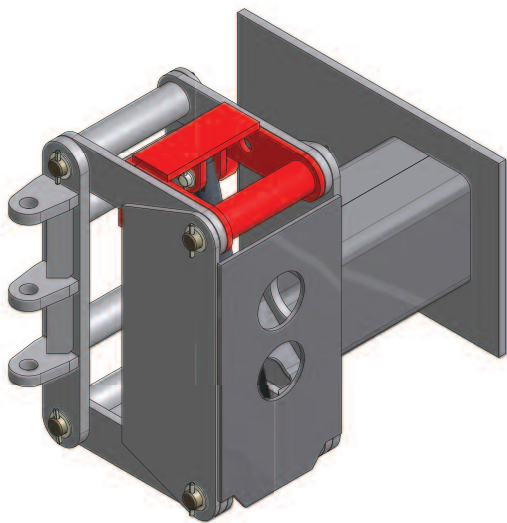

**Para-Glide Wing Post in Resting Position.**

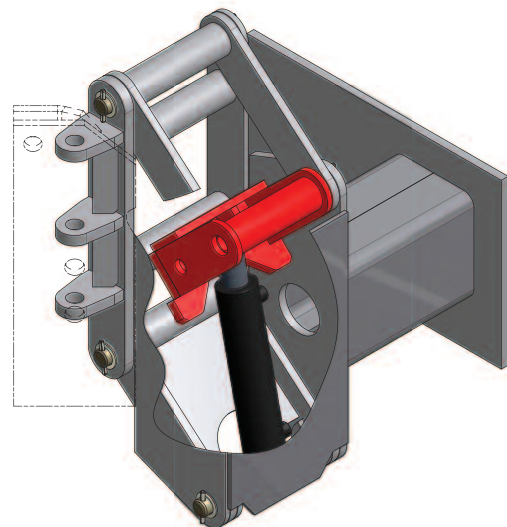

**Para-Glide Wing Post in Full Float Position.**

# Specifications

Specifications subject to change without notice.

	DFPW-8	DFPW-9	DFPW-10	DFPW-11	DFPW-12
Overall Moldboard Length	104"	116"	128"	140"	152"
Cutting Edge Length	8'	9'	10'	11'	12'
Height of Moldboard at Nose	29"	29"	29"	29"	29"
Height of Moldboard at Heel	39"	39"	39"	39"	39"
Moldboard Thickness	3/16"	3/16"	3/16"	3/16"	3/16"
Single Pusharm - Adjustable 4 Positions	OPT	OPT	OPT	OPT	OPT
Double Pusharms	OPT	OPT	OPT	OPT	OPT
Slide Cylinder	3x10	3x10	3x10	3x10	3x10
Lift Cylinder	4"ID x 21.75"	4"ID x 21.75"	3"ID x 15"	3"ID x 15"	3"ID x 15"
Weight of Complete Wing Assembly	1620	1690	1870	1985	2050
Weight of Moldboard	700	770	840	720	785
Clearing Width With 90° Push Arm Angle	58"	65"	72"	79"	87"



Shown with optional square pusharm.



## Options

Two Piece Torsion Trip Edge  
 Carbide Cutting Edge  
 Curb Guard  
 Full Trip Moldboard  
 Dual Pusharms  
 Moldboard Wear Shoe(s)

Decell Cylinder  
 Left Side or Dual Mount  
 Special Paint  
 Power Slide Push Arm  
 Mid or Rear Mount

Manufactured by:  
**Monroe Snow & Ice Control**  
 1051 W. 7th Street • Monroe, WI 53566  
 800-880-0109 • 608-329-8105  
 608-328-8390 Fax  
 Web: [www.monroetruck.com](http://www.monroetruck.com)  
 E-mail: [snowandicecontrol@monroetruck.com](mailto:snowandicecontrol@monroetruck.com)

Distributed by:

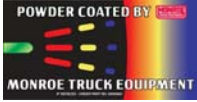

# MTE Powder Coat Paint Warranty

## Monroe Truck Equipment (MTE) Limited Warranty Coverage

- **Powder-coat paint finish** on Snow & Ice products, MTE production parts, and customer parts is warranted against **adhesion failure**, cracking, checking, peeling, delamination, and more than 10% loss of gloss **or color** for 1 year.
- **Powder-coat paint finish** on selected MTE Manufactured bodies is warranted against **adhesion failure**, cracking, checking, peeling, and delamination for 3 years or 36,000 miles. No more than 10% loss of gloss **or color** for 1 year. See warranty document for specific products.

## Eligibility for Warranty Coverage

- Warranty period commences from the in-service date for Snow & Ice products, MTE Manufactured bodies, and MTE production parts.
- Warranty period commences from the invoice date for customer parts.
- Original owners of S & I products and Manufactured bodies must complete and submit the Warranty Registration Card within thirty (30) days of purchase.
- The product must be used for its intended purpose.
- The product must be maintained and serviced according to the guidelines in any supplied owner's manual.

## Exclusions

- This warranty applies only to powder coat paint applied by MTE at Monroe, Wisconsin.
- This warranty does not apply to powder coat paint applied to customer parts unless MTE has approved the material(s) of construction and has performed all required surface preparation steps.
- Warranty does not apply to any product that has been altered, abused, or misused.
- Warranty does not apply to products and bodies sold and used outside the United States and Canada.
- Painted surfaces must not be subjected to highly corrosive chemicals.
- Rust and perforation resulting from damage related to collisions, accidents, scratches, impacts, or normal and intended use of the product are not covered.
- Restoration of lettering, signs, and custom paint applications is not covered at any time if paint repairs are required.
- This warranty is not transferable.

## Warranty Repairs

During warranty repairs to powder-coat paint, MTE will strive to restore the original paint coating. **Where paint has suffered complete adhesion failure, a part or body may be processed to remove all existing powder coat and new powder coat applied. Where deemed most practical, a small part may be replaced with a new powder-coated part.**

Repairs involving reapplication of powder coat paint shall be performed only at the MTE facility in Monroe, Wisconsin.

Where the original powder coat can not be effectively removed for repair **or a defect is cosmetic only, and the surface adhesion of the existing powder coat is good**, MTE retains the right to repair a powder-coat painted surface using a wet-coat paint process. **The underlying powder-coat paint will remain as a base for the wet coat.** Wet-coat repairs to powder coat paint may be performed at any MTE facility or at an approved automotive body repair shop.

## Peripheral, Incidental, and Consequential Damages and Claims

The MTE limited warranty does not apply to damage and failure resulting from misuse, abuse, neglect, accident, improper customer/distributor installation, lack of maintenance, or acts of God. Any modifications by the buyer or any third party, without the prior written consent of MTE, may void this warranty. Operating conditions or applications not made known to or contemplated by MTE at the time of delivery to the buyer may also void this warranty. Damages resulting from any other abnormal operation will not be covered by this warranty.

Normal wear, reaction to corrosive operating environment, and premature failure due to poor maintenance are not covered under this warranty.

MTE will not reimburse for lost time, business, or business opportunity, or for any loss of use related to warranty claims. MTE will not provide or pay for the use of a rental vehicle, equipment, or tools while warranty work is performed. MTE will not reimburse for equipment or tools that are damaged, lost, or missing in conjunction with a warranty claim. MTE is not responsible for and will not reimburse for mileage, fuel, and wear incurred in the process of driving the vehicle to a repair site or delivery to the end user location, nor for lost time incurred by an owner delivering and picking up a vehicle.

***This limited warranty is the sole and exclusive remedy for defective products manufactured and/or installed by MTE.***

Policy revision/effective date: 05/07/08



## MTE Powder Coat Questions and Answers

**QUESTION: How many custom colors do you offer?**

Answer: The number of colors available is unlimited when a liquid paint code is supplied to MTE. These custom colors require a minimum purchase of 50lbs of powder material.

**QUESTION: If I have a special custom color which is metallic, what options do I have for powder coating?**

Answer: The original base powder coat may be used as a base primer. The body could be completely recoated with a liquid metallic top coat which would still give you all benefits of using only powder.

**QUESTION: How does powder coat compare to wet spray?**

Answer: On average, with a standard industrial coating, powder coat will be two to three times stronger. If a very high quality urethane with a good primer base is used, performance is about the same.

**QUESTION: What are my options, if my powder coated body is damaged and needs to be repainted?**

Answer: A powder coated body would be treated for panel/spot repair using the same process and methods as a liquid painted body. A powdered top coat can be sanded/primed and spot blended with any high quality liquid paint.

### Customer Testimonials

*"We use our trucks and equipment in a high chemical and high abrasive environment. Powder coating is the best route for several reasons. The main reason for us is the appearance because we like to have the image of always having superior and functional equipment. For this reason a powder coat finish is the best option for us on our salt spreaders. We also have had great results from the powder coat finish on our Snow Bully Snow Pushers. We own over 20 Of them and we have never had to repaint a single one. Some of the v-boxes we have are 10 years old and have had heavy usage. They also have never been repainted. Only minor touch ups due to either driver or loader error. We will never use any type of equipment that does not have a powder coat finish. That is one of the reasons we use Monroe Snow & Ice Control Products exclusively!"*

- Trevor Biebrach, Director of Operations, Snow Systems Incorporated



SCRAPERS • PLOWS • SPREADERS • HITCHES • WINGS • SPINNERS  
 DUMP BODIES (LARGE AND SMALL) • PLATFORM BODIES • UTILITY BODIES  
 BUMPERS • SNOW & ICE COMPONENTS • TRUCK FRAMES • OIL TANKS  
 MOTOR CYCLE FRAMES • ATV FRAMES • TRAILERS • CHIPPER CAPS  
 ROLL BARS • RIMS • RAILINGS • LADDER RACKS • VAN BODY COMPONENTS  
 RDS BODIES • DTS BODIES • DVS BODIES • VAN BODY COMPONENTS  
 TOWING BODIES • TOOL BOXES • HITCH CARRIERS  
 SCRAPERS • PLOWS • SPREADERS • HITCHES • WINGS • SPINNERS  
 DUMP BODIES (LARGE AND SMALL) • PLATFORM BODIES • UTILITY BODIES  
 BUMPERS • SNOW & ICE COMPONENTS • SUB-FRAMES • TRUCK FRAMES  
 MOTOR CYCLE FRAMES • ATV FRAMES • TRAILERS • OIL TANKS  
 ROLL BARS • RIMS • RAILINGS • LADDER RACKS • CHIPPER CAPS  
 RDS BODIES • DTS BODIES • DVS BODIES • VAN BODY COMPONENTS  
 TOWING BODIES • TOOL BOXES • HITCH CARRIERS  
 SCRAPERS • PLOWS • SPREADERS • HITCHES • WINGS • SPINNERS  
 DUMP BODIES (LARGE AND SMALL) • PLATFORM BODIES • UTILITY BODIES  
 BUMPERS • SNOW & ICE COMPONENTS • SUB-FRAMES • TRUCK FRAMES  
 MOTOR CYCLE FRAMES • ATV FRAMES • TRAILERS • OIL TANKS • VAN BODY

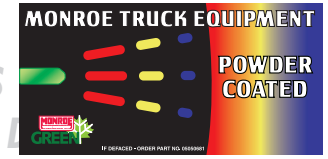

**MTE Achieving Exceptional Quality Finishes, Our Customers Demand**



**POWDER COAT**



- Environmental
- Economical
- Durable



Monroe Truck Equipment  
 1051 W. 7th Street, Monroe, WI 53566  
 PH: 800-356-8134  
 www.monroetruck.com

Celebrating 50 Years!



## MTE Powder Coating with Leading-Edge Technology Since 1997

**Powder Coating:** is a unique process of coating a surface on which powder material is applied using an electrostatic or compressed air method. The applied powder is then heated (cured) in an oven to it's melting point, after which it flows to form a smooth film, that dries to a firm, durable finish of superior consistency and uniformity. The finish free of chips, runs or bubbles, is extremely resistant to scratches, cracking, peeling, UV rays and rust.

### Advantages:

- The ability to withstand high levels of corrosion due to salt, chemicals, humidity, scratching and impact, far surpassing conventional paint top coats.
- Resists fading from U.V. rays
- Environmentally green process, free of harmful VOC air pollution
- Excellent adhesion
- High degree of scuff, chip and scratch resistance



### The entire powder coating process involves several steps:

- The product is cleaned using an abrasive blasting or a chemical cleaning process to insure the substrate is free of any oils, dirt, rust, mill scale, etc.
- The product is treated with a pre-treatment chemical or conversion coating, usually phosphate or zinc based, to further protect it and improve the surface for powder adherence.
- The product is rinsed thoroughly and dried completely.
- It is very important that the right coating is chosen for your application and end use of the item.
- The product is powder coated with an electrostatic gun in a powder coat booth.



### Environmental Benefits

- Environmentally SAFE Process
- Emits NO VOC's (volatile organic compounds)
- Contains NO Heavy Metals
- NO Solvent Disposal
- Overspray can be Reclaimed



### Effectiveness:

- Exceeds 1000 hours of salt spray resistance.
- 3X Stronger than industrial grade liquid in same environment\*

\*Based on Tests performed by Monroe Truck Equipment.

### Powder Coated Products

- Scrapers
- Plows
- Spreaders
- Hitches
- Wings
- Spinners
- Dump Bodies (Large & Small)
- Platform Bodies
- Utility Bodies
- Tailgate Spreaders
- Bumpers
- Snow & Ice Components
- Sub-Frames
- Truck Frames
- Car Frames
- Motor Cycle Frames
- ATV Frames
- Oil Tanks
- Roll Bars
- Rims
- Railings
- Ladder Racks
- Chipper Caps
- Van Body Components
- Tool Boxes
- Towing Bodies
- Hitch Carriers



## MTE Offers Manual or Batch Powder Coat Systems

### Manual Capacity:

- Washer: 56"H x 96"W x 192"L
- Shot Blaster: 45"H x 60" W x 168"L
- Weight Limit: 3500lbs.

Wash System - 5 Stage Washer with RO Water



**BLAST**



**WASH**



**PAINT**



**CURE**

Max Temperature: up to 430°

### Batch Booth Capacity:

- Length: 228"
- Width: 108"
- Height: 96"

Wash System - Steam Generated Pressure Wash System with RO Water

**WASH**



**PAINT**



**CURE**



Max Temperature: up to 430°

### Available Powder Coat Color Spectrum

- MTE has a wide variety of stock colors on hand.
- MTE can have a custom matched color in 7-10 days.
- MTE works with the industry's top manufacturers to develop powder paints that rival liquid paint appearance, and provide better corrosion and U.V. resistance.



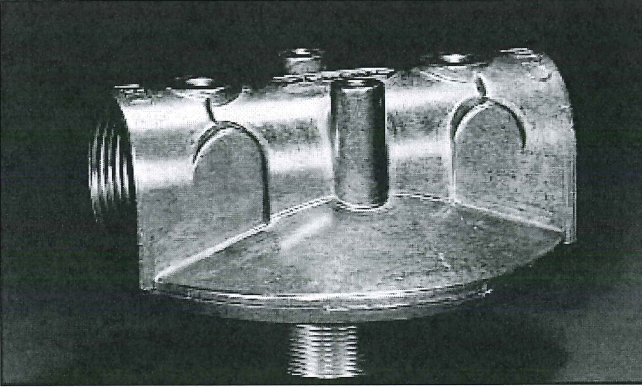

# SF-120 SERIES SPIN-ON FILTER HEADS

Flows Up To: 70 GPM (Return) 25 GPM (Suction)  
 Port Sizes: • 1 1/4" NPTF  
 • 1 1/4" BSP  
 • 1 5/8" - 12 UN (SAE - 20)  
 Pressure: 200 PSI Max. Operating  
**Warning: 80 PSI ΔP max. without by-pass valve.**  
 Temperature: Up to +250° F. Operating  
 Applications: Petroleum based fluids only.  
 Consult factory for synthetic fluids.

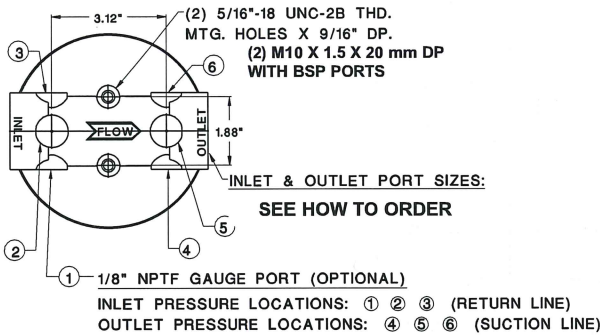

**Average Pressure Drop Through Clean Filter Assembly With 150 SUS Oil At 105° F.**

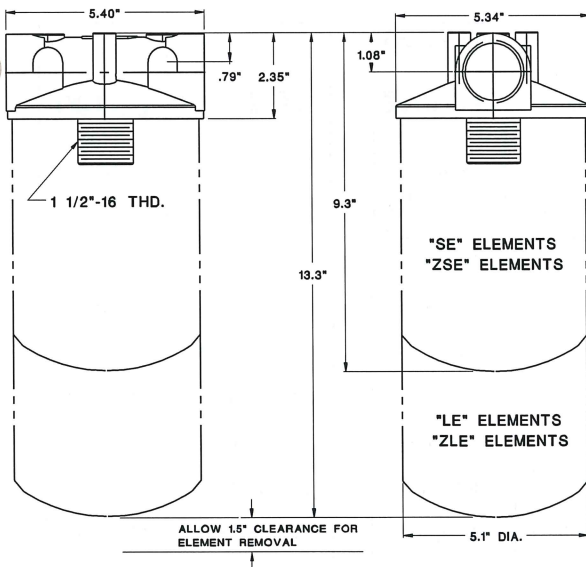
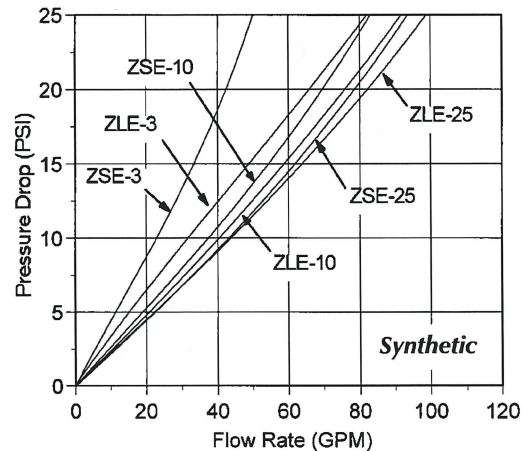
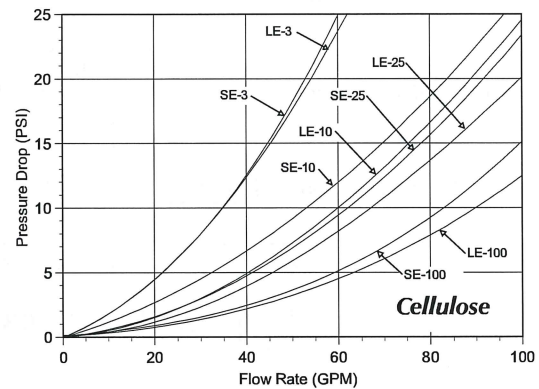

**HOW TO ORDER:**

**SF - XXX - XX - X**

Code	Inlet & Outlet Ports
120	1 1/4" NPTF
120C	1 1/4" BSP (G 1 1/4"-11)
160	1 5/8"-12 UN-2B(SAE- 20)

Code	By-Pass Valve Setting
00	No By-Pass
03	3 PSI
05	5 PSI
15	15 PSI
25	25 PSI
50	50 PSI

Code	Gauge Port Location
0	No Port Required
Location Number	As Shown Above

**SE, LE, ZSE, & ZLE Element Data: See Pages C26-C27**

# SE & LE SERIES SPIN-ON FILTER ELEMENTS

For Use With SF, DF, MF, MFT & ZDF Series Filter Heads

SPIN-ON FILTERS

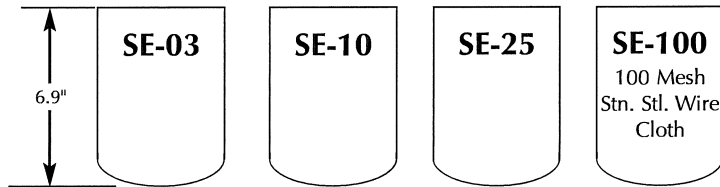

Part Number	SE-03	SE-10	SE-25	SE-100
Diameter	5.1"	5.1"	5.1"	5.1"
Mounting Thread	1 1/2" - 16	1 1/2" - 16	1 1/2" - 16	1 1/2" - 16
Micron Rating	3 Micron	10 Micron	25 Micron	141 Micron
Beta 2/20/75 (See Below)	3/10/22	9/22/24	29/46/54	-----
Filter Media Area	850 Sq. In.	950 Sq. In.	950 Sq. In.	200 Sq. In.
Can Color / Imprint	White/Green	White/Red	White/Black	White/Blue

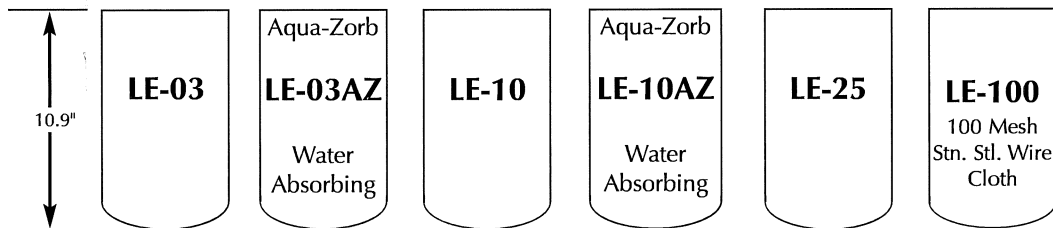

Part Number	LE-03	LE-03AZ	LE-10	LE-10AZ	LE-25	LE-100
Diameter	5.1"	5.1"	5.1"	5.1"	5.1"	5.1"
Mounting Thread	1 1/2" - 16	1 1/2" - 16	1 1/2" - 16	1 1/2" - 16	1 1/2" - 16	1 1/2" - 16
Micron Rating (Nominal)	3 Micron	3 Micron	10 Micron	10 Micron	25 Micron	141 Micron
Beta 2/20/75 (See Below)	3/10/22	5/21/23	10/22/33	8/25/30	29/46/54	-----
Filter Media Area	1170 Sq. In.	648 Sq. In.	1710 Sq. In.	648 Sq. In.	1710 Sq. In.	380 Sq. In.
Water Holding Capacity	-----	15 oz.	-----	15 oz.	-----	-----
Can Color / Imprint	White/Green	White/Orange	White/Red	White/Orange	White/Black	White/Blue

### Application Data:

- Reference:
  - Beta<sub>x</sub> Rating of 2 = 50% Efficiency (Nominal Rating)
  - Beta<sub>x</sub> Rating of 20 = 95% Efficiency
  - Beta<sub>x</sub> Rating of 75 = 98.7% Efficiency (Absolute Rating)
- Maximum Operating Pressure: 200 PSI All Models.  
**Warning: 80 PSI ΔP max. without by-pass valve in filter head.**
- Operating Temperature: -65 to +250° F.
- Application: Suitable for petroleum based fluids only. Consult factory for synthetic fluids.
- Buna "N" Gasket standard. Fluorocarbon Gasket optional, consult factory.
- Consult local distributor or factory for SE & LE Element interchange with those of other manufacturers.
- **Caution:** Do not use SE & LE Series filter elements on internal combustion engines.

# ZSE & ZLE SERIES SYNTHETIC MEDIA SPIN-ON FILTER ELEMENTS

For Use With SF, DF, MF, MFT & ZDF Series Filter Heads

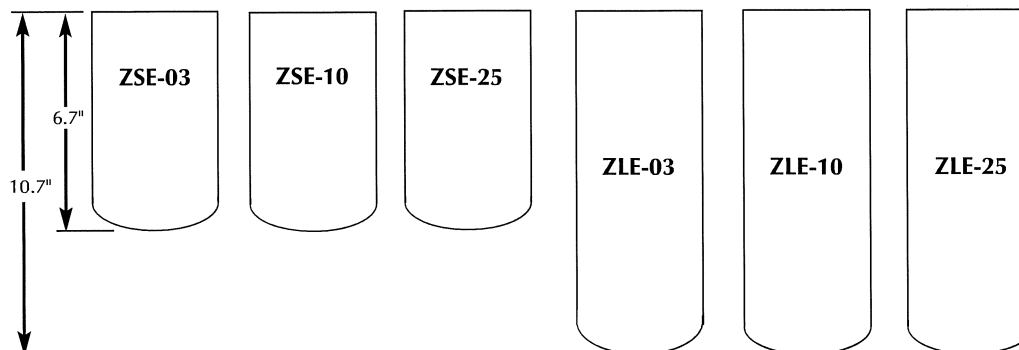

SPIN-ON FILTERS

Part Number	ZSE-03	ZSE-10	ZSE-25	ZLE-03	ZLE-10	ZLE-25
Diameter	5.1"	5.1"	5.1"	5.1"	5.1"	5.1"
Mounting Thread	1 1/2"-16	1 1/2"-16	1 1/2"-16	1 1/2"-16	1 1/2"-16	1 1/2"-16
Micron Rating (Nominal)	3 Micron	10 Micron	25 Micron	3 Micron	10 Micron	25 Micron
Beta 2/20/75 (See Below)	2/3/4	4/10/12	8/25/30	2/3/4	4/10/12	8/25/30
Filter Media Area	680 Sq. In.	561 Sq. In.	673 Sq. In.	1260 Sq. In.	1041 Sq. In.	1246 Sq. In.
Can Color / Imprint	White/Green	White/Red	White/Black	White/Green	White/Red	White/Black

## Application Data:

- Reference:
  - Beta<sub>x</sub> Rating of 2 = 50% Efficiency (Nominal Rating)
  - Beta<sub>x</sub> Rating of 20 = 95% Efficiency
  - Beta<sub>x</sub> Rating of 75 = 98.7% Efficiency (Absolute Rating)
- Maximum Operating Pressure: 200 PSI All Models.
  - Warning: 80 PSI ΔP max. without by-pass valve in filter head.**
- "Z-Glass" Media
- Operating Temperature: -65 to +250° F.
- Application: Petroleum based fluids only. Consult factory for synthetic fluids.
- Buna "N" Gasket standard. Fluorocarbon Gasket optional, consult factory.
- Caution:** Do not use ZSE/ZLE Series filter elements on internal combustion engines.



## MONROE TRUCK EQUIPMENT, INC. WARRANTY SNOW & ICE CONTROL PRODUCTS

**Monroe Truck Equipment, Inc.** warrants to the original purchaser, that if any part of the product proves to be defective in workmanship or material within **ONE YEAR** of the original installation, and is returned to us within 30 days of the discovered defect, we will (at our option) repair or replace the defective part. This warranty does not apply to damage resulting from misuse, neglect, accident, improper installation, normal wear items or lack of maintenance. This warranty is exclusive and supersedes all other warranties, whether expressed or implied. **Monroe Truck Equipment, Inc.** neither assumes, nor authorizes anyone to assume for it, any other obligation or liability in connection with this warranty and will not be liable for consequential damages.

All engines, pumps, motors, cylinders and valves are warranted by their manufacturer and not by **Monroe Truck Equipment, Inc.**. The manufacturer's warranty will apply to these parts. Electrical and hydraulic components are not to be disassembled without the express written permission of Monroe Truck Equipment. Use of replacement parts other than original equipment voids this warranty.

All defective parts returned must be accompanied by the model number, serial number, date installed, date of defect, description of defect, and the name of the distributor from whom it was purchased. All warranty claims must have prior written approval from **Monroe Truck Equipment, Inc.**

***Please return the warranty registration card that accompanies this manual to confirm receipt of this parts catalog and acknowledge the information contained within. Failure to return the attached card may result in a voided warranty.***

# **Warranty Policy**

## **Uninstalled Parts and Equipment provided by Monroe Truck Equipment**

Monroe Truck Equipment will provide the following limited warranty for a period of one year to the original purchaser of all uninstalled goods provided by Monroe Truck Equipment:

**LIMITED WARRANTY:** All goods provided by Monroe Truck Equipment (MTE) will be free from defects in material and workmanship for a period of one year from the date of purchase by the original purchaser. This limited warranty shall be the sole and exclusive remedy for any such product found to be defective. This limited warranty supercedes all previous warranties and is exclusive and in lieu of all other warranties, whether expressed or implied.

This limited warranty applies only to parts or accessories manufactured by MTE and/or provided by same. Except with respect to title, this limited warranty does not pertain to parts or accessories not manufactured and/or provided by MTE, regardless of whether such parts or accessories were selected and/or recommended by MTE. MTE will, as a service to the buyer, pass on any warranties received from the original manufacturer of MTE provided parts and/or accessories.

MTE will not under any circumstances be liable for any incidental or consequential damages whether in tort, contract, or otherwise, for any bodily injury, death, property damage, loss of use, or loss of income resulting from or in any way arising out of any goods provided by MTE, or their sale, use, or manufacture.

Any warranty claim deemed to be arising from the result of misuse, abuse, neglect, accident, improper installation, lack of maintenance, act of war (whether declared or otherwise), or act of God will be denied. Any repair or modification by the buyer or any third party, without the prior written consent of MTE, will void any possible warranty compensation. Any damage deemed to be the result of abnormal operation will not be compensated by this warranty.

Normal or special maintenance items such as fuels, fluids, tires, belts, hoses, filters, air cleaners, light bulbs, and any other items subject to normal wear and tear that are supplied in connection with goods provided by MTE are not allowed under this warranty.

All engines, pumps, cylinders, valves, and motors are warranted by their manufacturer and not by Monroe Truck Equipment. The manufacturer's warranty will apply to these parts. Electrical and hydraulic components are not to be disassembled without the express written consent of MTE. Any disassembly of MTE provided components without prior authorization will void the applicable warranty.

Monroe Truck Equipment shall be the sole and final determining authority as it applies to the administration of this warranty policy. Purchaser acknowledges receipt of Monroe Truck Equipment Warranty Policy and agrees to be bound by same.

Any and all warranty claims must be forwarded to MTE within 10 days of defect discovery. A copy of the original Monroe Truck Equipment invoice as well as the manufacturer's model number, serial number, and date of installation must accompany all correspondence regarding said claims. MTE will, at their option, choose whether to repair or replace the defective part unless otherwise specified by the original manufacturer of said part.

### **Procedures for Warranty Claims Notification**

For submission of any warranty claim please contact Monroe Truck Equipment – Warranty Department at 800-356-8134

The following documentation will be needed when you call for initial warranty authorization:

A copy of the original MTE invoice.

Make, Model, and VIN or Serial Number of the equipment involved.

Part number and serial number of the part in question.

A complete description of the problem.

The following must accompany any claim submitted to Monroe Truck Equipment:

Documented photographs of any physical damage.

Inspection notes by MTE personnel or MTE authorized 3<sup>rd</sup> party.

Authorization number issued by Monroe Truck Equipment – Warranty Department.

**Defective parts must be returned to Monroe Truck Equipment (freight prepaid) within 30 days of issuance of Authorization Number.**

**Monroe Truck Equipment reserves the right to void any warranty for failure to comply with Monroe Truck Equipment Warranty Policy.**

**This policy is effective January 1, 2004**





## ENGINEERED TARPING SOLUTIONS



### The Original **SHUR-LOK®** for **END DUMPS**

*Dependable watertight protection for whatever you're hauling!*

#### VALUE SERIES or SUPER DUTY SHUR-LOK®

- Aluminum Latchplate
- Rear Fabric Cap/Flap
- Easy-Off Front Fabric Cap
- Easy-Off Tarp Stops
- Shur-Flex™ Crank Arm
- Front Roll Return
- Crank Retainers
- 22-Oz. Vinyl-Coated Tarp

Our base-model Shur-Lok® will do the job for you – and do it well, but if you like to customize, we have plenty of options and upgrades. If you have additional requirements, we are willing and able to custom manufacture to meet your exact specifications.\*

For more information, give us a call. Customer service representatives are standing by to help with any questions you may have.

*\*Additional costs may apply.*

The Shur-Flex™ crank arm offers convenient flexibility. It folds at the knuckle and secures with offset or pinless offset retainers – no more pin-and-cable hassles. It can be customized to fit your trailer.



The easy-off front fabric cap makes it easier to come over the top of the doghouse. Double bows secure into a double bow bracket – exactly the right spacing for tightening down the front of the tarp.



The front stretch roll return guides the roll tube over the cap end, and its protective cover keeps the rope from fraying on the latchplate. Or upgrade to our exclusive Shur-Return® with heavy-duty steel tension spring and lifetime warranty.



Reinforced stitching along the radius corner of the front fabric cap increases tear strength and helps the tarp withstand the stresses of traveling at highway speeds.



BOX DETAIL SHEET ON REVERSE SIDE.

1-800-474-8756

www.shurco.com

# BOX DETAIL SHEET *for* END DUMPS

## CONTACT INFORMATION

NAME \_\_\_\_\_  
 ADDRESS \_\_\_\_\_  
 CITY \_\_\_\_\_ STATE \_\_\_\_\_ ZIP \_\_\_\_\_  
 PHONE \_\_\_\_\_ FAX \_\_\_\_\_  
 BOX/TRAILER MAKE \_\_\_\_\_

## OUTSIDE DIMENSIONS

A \_\_\_\_\_ UPPER BOX LENGTH  
 U \_\_\_\_\_ INSIDE BOX WIDTH  
 B \_\_\_\_\_ UPPER BOX WIDTH  
 Front \_\_\_\_\_ Center \_\_\_\_\_ Rear \_\_\_\_\_  
 N \_\_\_\_\_ TOP RAIL WIDTH  
 X \_\_\_\_\_ BOX HEIGHT

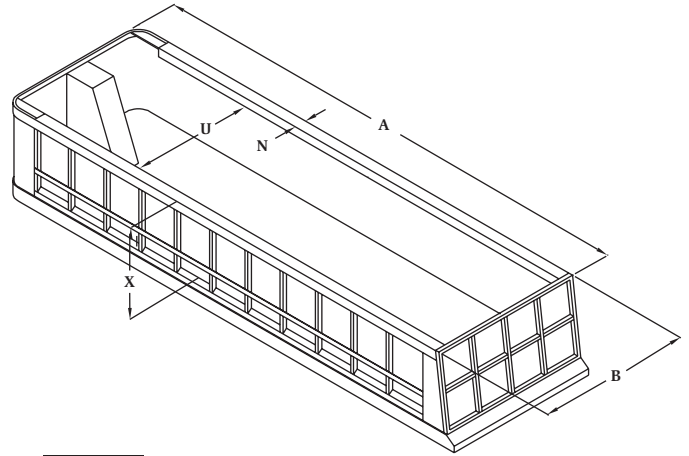

## CORNER CONFIGURATION (See Figure 1.) **MUST SELECT ONE.**

- SQUARE  DIAGONAL  RADIUS/NO RECESS  
 SQUARE RECESS  DIAGONAL RECESS
- C \_\_\_\_\_ OUTSIDE CORNER RADIUS (Needed on all radius fronts.)  
 D \_\_\_\_\_ RECESSED WIDTH  
 E \_\_\_\_\_ FLAT ACROSS FRONT  
 F \_\_\_\_\_ FRONT TO CORNER POST  
 G \_\_\_\_\_ GUSSET LENGTH  
 V \_\_\_\_\_ FLAT ACROSS DIAGONAL  
 W \_\_\_\_\_ DIAGONAL DEPTH

## TOP RAIL STYLE (See Figure 2.)

- SQUARE  SELF CLEANING  SQUARE W/PLANKS\*  
 \*Are planks flush with outside of top rail? Y / N (Circle one.)

## TOP RAIL DROP (See Figure 3.)

- FRONT  REAR
- L \_\_\_\_\_ BULKHEAD DEPTH O1 \_\_\_\_\_ FRONT TOP RAIL DROP  
 M \_\_\_\_\_ THRESHOLD DEPTH O2 \_\_\_\_\_ REAR TOP RAIL DROP

## FRONT END STYLE (See Figure 4.)

- RAISED FRONT SHIELD  RAISED SHIELD & FLAT TOP RAIL  
 SLANT w/CURVED RAISED FRONT  SLANT w/SQUARE RAISED FRONT  
 SQUARE TUB w/INVERTED RAM
- AD \_\_\_\_\_ CYLINDER HEIGHT J \_\_\_\_\_ UPPER SHIELD WIDTH  
 AE \_\_\_\_\_ DOGHOUSE DEPTH J1 \_\_\_\_\_ DOGHOUSE WIDTH  
 H \_\_\_\_\_ SHIELD HEIGHT K \_\_\_\_\_ LOWER SHIELD WIDTH

## REAR DUMP STYLE (See Figure 5.)

- OVERSLUNG HINGE GATE  COMBO DOOR HINGE GATE  
 HIGH POWER LIFT GATE  RAISED HINGE GATE
- AF \_\_\_\_\_ HINGE DEPTH  
 AK \_\_\_\_\_ HINGE HEIGHT  
 B \_\_\_\_\_ BOX WIDTH/REAR

## TARP WEIGHT and COLOR(S)

22 OZ. \_\_\_\_\_

Figure 1

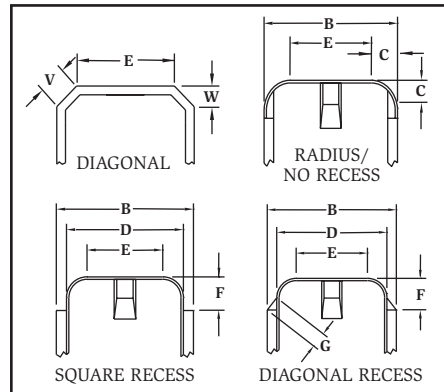

Figure 2

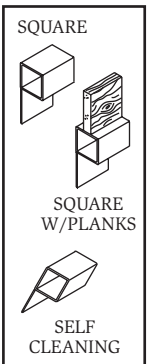

Figure 3

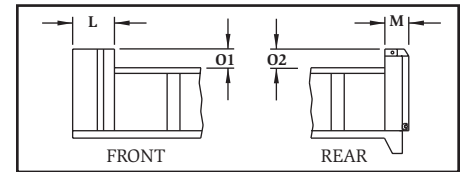

Figure 4

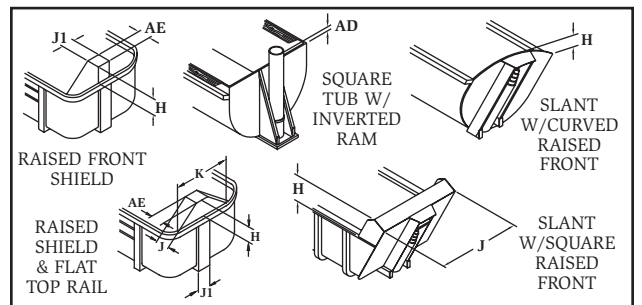
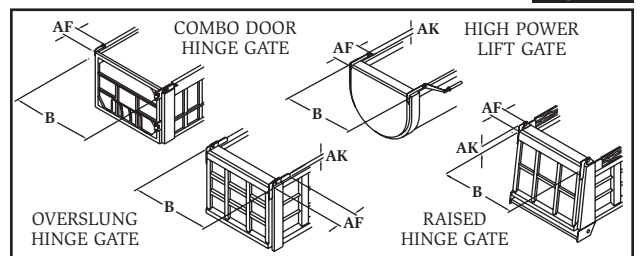

Figure 5



FAX 1-605-665-0501

Salesperson \_\_\_\_\_